

Monographs on Tea Production In Ceylon

ISSUED BY

THE TEA RESEARCH INSTITUTE
OF CEYLON

No. 4

TEA MANUFACTURE IN CEYLON

BY

E. L. KEEGEL

Technologist

Reprinted

1983



First published	1956
Revised edition	1958
Re-printed	1965
Re-printed	1983

CONTENTS

	PAGE
1. The principles of tea manufacture	7
2. Introduction to the practice of tea manufacture ...	18
3. Thermometry and Hygrometry	26
4. Withering	28
5. Rolling	42
6. Continuous Rolling	67
7. Roll-breaking	71
8. Fermentation	77
9. Firing	86
10. Grading	99
11. Storage and Packing	112
12. Factory Organization	116
13. Tea Characteristics and Common defects ...	129
14. Tea Tasters' Terms	134
15. Factory Hygiene	138
Appendixes	140
Bibliography	161
Index to Tables, Figures, Diagrams and Plates ...	166
Subject Index	168

TEA MANUFACTURE to be

Effectively

Accomplished

Must

Always

Need an

Understanding of the principles,

First-class material,

Attention to detail,

Cleanliness,

Technical skill, and

Undoubtedly the

Right

Equipment

E. L. K.

FOREWORD

BY

Dr. A. W. R. Joachim, O.B.E.
Acting Director

TEA RESEARCH INSTITUTE OF CEYLON

It is my privilege to be associated with the Tea Research Institute of Ceylon as its Acting Director at the time when Mr. E. L. Keegel is bringing out the second edition of his popular monograph on "Tea Manufacture in Ceylon." The fact that within the comparatively short period of two years the first edition of 3,500 copies ran out of print—about one fifth of that number was sold—is proof of the usefulness and value of the publication to tea planters and others connected with the crop in all parts of the tropical world.

The new edition, though not radically different to its predecessor, brings up to date our knowledge of and ideas on tea manufacture. Features of interests in this connection are the references to the continuous rolling process and the Keegel cone, and to certain aspects of fermentation. The value of the monograph is enhanced by the inclusion in the new edition of a useful glossary of tea tasters' terms and a set of specimen record sheets for use in the factory.

It is common knowledge that tea production in this Island has increased very appreciably during the past decade and now approaches the figure of 400 million pounds per annum. The fact that, by and large, the quality of the teas exported in recent years has not fallen short of previous standards to any appreciable degree despite the increase of yield, is proof that tea manufacturing standards are being maintained at a satisfactory high level in the country generally, and that the correct practices and techniques both in field and factory for producing teas of good quality are becoming more widely known than before. This desirable state of affairs could, in some measure at any rate, be attributed to the influence of the monograph on those who have most to do with tea manufacture in Ceylon.

The writer is aware of the encomiums that have been received in regard to the value of the book from overseas correspondents of this Institute, and the fact that there have been very large numbers of advanced booking for the second edition is a tribute to its sound practical utility. The author has indeed justifiable cause to be satisfied with his efforts. He has recently started on new lines of investigation, particularly in relation to rolling and fermentation, and with the opportunities which would be afforded him at the new low-country sub-station for the study of the manufacture of low-country teas and their improvement, there is little doubt that it would not be many years before a third edition of this book would become necessary. Meanwhile all those connected with the manufacture of our common black teas should be beholden to him for his clear, simple, practical, and yet withal, accurate exposition of a subject which is not only of much scientific and technical interest, but of considerable economic importance.

P R E F A C E

TO THE SECOND EDITION

The reception given to the first edition of this monograph has given me great satisfaction. It makes me feel that it has fulfilled the purpose for which it was written. As it was hurriedly prepared I find now that it contains certain errors, omissions and vague statements, which though not of a serious nature may be somewhat misleading. In this edition I have therefore tried to eliminate these shortcomings to the best of my ability and at the same time bring the subject up to date.

Since the first edition was written in 1956 more knowledge has been gained on certain aspects of rolling and fermenting and the reader will find that in this respect some of the views now given may not be entirely consistent with those published earlier.

No great advances in tea manufacture have been made within the last two years, so the general scope of this book remains much as before. Three additions, however, have been made to which I would invite the reader's attention. The first deals with a new type of roller cone; the remaining two are a glossary of tea-tasters' terms and a set of specimen record sheets recommended for use in a factory.

Finally, I should like to express my thanks to the many people who, by their appreciation of the first edition, have given me the necessary encouragement to publish a second one.

E. L. KEEGEL.

July, 1958.

CHAPTER I

THE PRINCIPLES OF TEA MANUFACTURE

During the past twenty years a great deal of basic research has been carried out on the process of tea manufacture, and it is now possible to fill in at least an outline of the principal chemical changes taking place between withering and firing. It is essential that the students of tea manufacture should have some elementary knowledge of these changes, for, without such understanding, it is impossible to grasp the principles of the process.

Until comparatively recently it was, more or less, assumed that the principal constituents of tea leaf were tannins or tannic acid and that fermentation was a process in which tannins were fermented by yeasts and bacteria, thereby losing their astringent, bitter properties and gaining in colour and aroma. This conception was erroneous for tea leaf does not contain any true tannins or tannic acid, and micro-organisms such as yeasts and bacteria have no essential place in normal tea fermentation. Micro-organisms, especially if machinery and equipment are not regularly cleaned, may give rise to taints, and perhaps more rarely some less objectionable but highly erratic characters. They are, however, entirely extraneous.

The principal constituents of the leaf are a group of soluble substances which can be simply referred to as oxidizable matter, together with pectins, caffeine, and aromatics. The principal agents bringing about fermentation are enzymes contained in the tea leaf which are mixed with the oxidizable matter and pectins by the rolling process. In the living leaf the enzymes are kept apart from oxidizable matter and pectins in separate parts of the leaf cells. It is possible that in the living cell the enzymes take some part in building up the substances which they break down in the ruptured cell, in other words that fermentation is a reversal of some growth process but it is an abstruse point which need not concern us further.

Oxidizable Matter—The group of substances which we will simply call oxidizable matter, accounts for some 35—45% of the dry matter in the tea leaf and very largely contributes to the colour and strength of tea liquors. It probably makes a substantial contribution to pungency and quality, but this is another abstruse point. This group of substances was formerly referred to as tannins or tannic acids which was unfortunate, because it has led to many misguided notions about the effects of tea liquors upon human intestines. Chemists have a habit of grouping chemicals into “families” on account of some common features in the construction of the molecules just in the same way as architects use specific terms for certain types of structure. The alkaloids for instance, of which family strychnine and morphine are both members, all have certain common structural features, but when it comes to their action on the human body no two drugs could be more in contrast, for strychnine is a powerful stimulant and morphine a powerful hypnotic.

The vegetable tannins are a very large chemical “family” and some of them, usually loosely called tannic acids, possess the property of hardening animal tissues in general, and turning hide into leather in particular. Other members of the family such as witch hazel are only very mildly

TEA MANUFACTURE IN CEYLON

astinging and are used in face lotions. Similar astringents are put to less characteristically feminine purposes in the treatment of "black-eyes".

Most, is not all the vegetable tannins take up oxygen from the air especially when they are mixed with alkali. Pyrogallol is very commonly used for the actual measurement of oxygen. A measured volume of gas containing oxygen, is bubbled through pyrogallol made alkaline with caustic soda, and then measured again, the loss in volume being a measure of the oxygen which has been absorbed.

During, or following the absorption of oxygen, the simple molecules of some of the vegetable tannins begin to clump together and form larger molecules which may become very stable and insoluble when the "condensed" molecules are very large. Plastics are made from various simple chemicals by controlled processes of this nature; in fact, phenol or carboric acid, which is one of the many simple members of this family of chemical compounds which we are now discussing, can be made into "bakelite" by condensing it with formalin. The highly condensed, complex molecules are usually described as "polymers".

It will be noted that it has been stated that this oxidation of compounds such as pyrogallol takes place under alkaline conditions. Pyrogallol mixed with acid will not take up oxygen but certain enzymes or plant ferments can oxidize pyrogallol under mildly acid conditions.

The members of this family of compounds which occur in tea are most correctly called tea catechins although they may also be called collectively tea polyphenols. Seven different distinct catechins have now been identified and it is possible that others in small quantities will be found. Just as a matter of interest the names of three of the seven catechins which have been found in tea from various sources are given in full:

1. L—epicatechin
2. L—gallo catechin
3. Galloylester of L—epicatechin

These catechins are soluble in water and a number of organic solvents such as ethyl acetate. They are colourless and have an astringent bitter taste. When the juice from fresh undamaged tea leaf is freshly pressed out it is practically colourless and will slowly develop a red colour on exposure to air because it will also contain enzymes which will start to ferment or oxidize the juice as soon as it is squeezed out. If the leaf is first steamed to kill the enzymes, juice pressed out from it will remain pale in colour for a considerable time, especially if a few drops of battery acid or even lime juice are added to it.

The juice will not of course be completely colourless because other colouring matter including chlorophyll—the green colouring matter of the leaf will also be squeezed out with catechins. If a few drops of alkali—even a solution of washing soda is added to the juice it will immediately begin to absorb oxygen and become first yellow and then dark brown. The changes will be slower in the fresh juice containing the active enzyme, and the transition from yellow to reddish yellow (orange or "new penny") and then after some hours, dark brown can be observed without difficulty.

The measurement of the amounts of the individual catechins involves weeks or even months of tedious chemical analyses. The catechins are, however, easily oxidized by chemicals which are oxidizing agents—substances such as potassium permanganate or hydrogen peroxide, and

THE PRINCIPLES OF TEA MANUFACTURE

a rough estimation of the quantities present in any sample of leaf may be carried out rapidly by oxidation with potassium permanganate and expressed as "total oxidizable matter" or T.O.M. We will, therefore, abandon the regular use of tongue-twisting words such as "catechins" and use the simple term "oxidizable matter."

Enzymes.—Enzymes are natural ferments contained in the tea leaf. They possess most remarkable powers, for despite the fact that they exist in the most minute quantities they can change many thousands of times their own weight of the chemical substances upon which they act, without loss of power. Somehow or other they fit into the architecture of the molecules upon which they act on a lock and key principle, and each enzyme acts as a key for one particular chemical structure *ad infinitum*. A simple illustration may be taken from sugars and starches. Starches are composed of molecules of simple sugars locked together. Depending on the way the simple sugars are locked together various different enzymes can unlock the particular structure they are designed by nature to fit. There is an enzyme in human saliva which unlocks the starch in bread; chew a piece of unsweetened bread for a few minutes so that it becomes thoroughly mixed with saliva and it will be found that the mass slowly becomes sweet to the taste because the complex starch molecules are becoming unlocked, setting free simple sugar molecules. Cut an apple or a potato and the cut surface which is exposed to air will rapidly turn brown in many varieties of apple and potato which contain polyphenols and enzymes very similar to those in tea leaf.

The leaf is naturally acid and the oxidizable matter in it does not change appreciably until it is either made alkaline—which never happens in practice unless lime is deliberately added to the leaf, or until it is oxidized by its specific enzyme. The enzyme with which we are at present concerned is called "tea polyphenol oxidase" and will only oxidize polyphenols with a special type of structure exactly similar to that occurring in the tea catechins. This enzyme takes up oxygen from air, unlocks a particular part of the catechin molecules which then take up oxygen and start clumping together or "condensing."

So long as the enzyme is mixed with the oxidizable matter, as occurs during rolling, it can go on oxidizing relatively enormous amounts of material compared to its own weight.

We have carried out intensive studies of "tea polyphenol oxidase" at the Tea Research Institute and in fact gave it the specific name. It was found to have a protein (like white of egg) carrier with an associated copper compound which oxidizes on exposure to air and then passes the oxygen on to the oxidizable matter in the juice. When the copper compound loses its oxygen it is said to become "reduced." As soon as the reduced copper is exposed to air, it takes up more oxygen and so it goes on oxidizing the oxidizable matter in contact with it.

The enzyme is very closely associated with leaf tissue and it may well be that its protein is part of the leaf protein so that it is evenly distributed right through the leaf and stalk mass, in minute quantities, but capable, so long as there is sufficient aeration, of oxidizing all the oxidizable matter which has been rolled out of the leaf cells or in any way exposed to air.

During withering, the evaporation of water concentrates the oxidizable matter. In fresh leaf the solution of oxidizable matter in the water contained in the leaf makes quite a thin solution which will run out of the leaf when it is broken up and the cell constituents are mixed. This also happens when the wither is too soft.

TEA MANUFACTURE IN CEYLON

The solution wrung out of properly withered leaf is concentrated to a tacky, varnish-like consistency and stays on the surface of the twisted leaf fully exposed to air. One of the major difficulties in fermenting leaf in "Kutchu" green leaf manufacture, and of under-withering, undoubtedly arises from a lack of aeration and re-absorption of fluid juice into the leaf tissue where the aeration is limited. Over-withering on the other hand makes too concentrated a solution which will not come out of the leaf, and again limits fermentation or oxidation.

The activity of the enzyme is dependent on temperature and it is most active between 80° and 90°F. At low temperatures, below 60°F, its action is very slow, so that warmth is essential for fermentation. The enzyme is rapidly destroyed at high temperatures and its survival is limited at any temperature above 120°F. When leaf is steamed as for instance in the preparation of green tea the enzyme is destroyed in 2-3 minutes.

Fermentation or Oxidation of Oxidizable Matter by Enzymes—As soon as withered leaf is rolled, conditions favourable to enzymic oxidation of the oxidizable matter in the leaf are set up. The oxidizable matter in undamaged withered leaf, it will be remembered, is almost colourless, astringent and bitter to taste possessing few or none of the characteristics which appeal to the consumer of black tea. The unfermented oxidizable matter does, however, satisfy the consumer of green tea who prefers the pale astringent liquor derived from unoxidized matter.

The heat generated during rolling, so long as it is not excessive, that is to say so long as the temperature in the roller does not exceed 90°F, stimulates the oxidation of the juice as it is wrung out of the leaf. Now rolling is a long, slow process and juices are only slowly extracted so there is little uniformity in the fermentation. Some of the oxidizable matter will be oxidized during the first few minutes of rolling, and will probably become over-fermented by the time the leaf is fired. Some of the oxidizable matter will only be wrung out and exposed to oxidation during the last few minutes of rolling, and will probably be under-fermented at firing time. Some juice will stay in the leaf and remain unoxidized.

The under-fermented and the completely unoxidized juice retain their astringent character and it is a moot point whether 100% complete fermentation is desirable. An excess of under-fermented or unoxidized juice will give the liquor a raw, bitter character, but small amounts may well be part of the character of good liquors. Whether pungency is a separate character or whether it is due to products of under-fermentation is one of the mysteries of tea-making.

It has already been explained that the enzyme only starts off a series of reactions by oxidizing part of the structure of the tea catechins which then begin to clump together and "condense" to larger and more complex molecules. This appears to be a slow continuous process and it is the simpler of the condensation compounds which give the character to the best liquors. The simpler condensation compounds are still soluble in hot water, and in organic solvents such as ethyl acetate. As condensation proceeds, the molecules grow larger in size to form compounds much less soluble in water and almost completely insoluble in ethyl acetate. The desirable intermediate compounds are bright in colour with a strong tinge of red, in other words, the colour of good tea liquors; whereas the more complex polymers are dark and dull, and ultimately become insoluble in water. These desirable reddish intermediate compounds have a taste of their own—the taste of good tea. They do not entirely lose their

OXIDISABLE MATTER.



Colourless
Astringent
Bitter
Soluble

Enzyme
Oxygen from air

OXIDATION COMPOUNDS.



Yellow
Astringent
Bitter
Soluble } Unstable

DESIRABLE INTERMEDIATE CONDENSATION COMPOUNDS

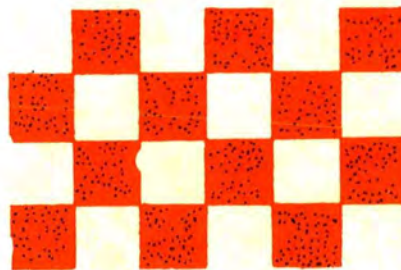

Reddish yellow
Tea character
Pungent
Soluble giving
bright solution

COMPLEX POLYMERS

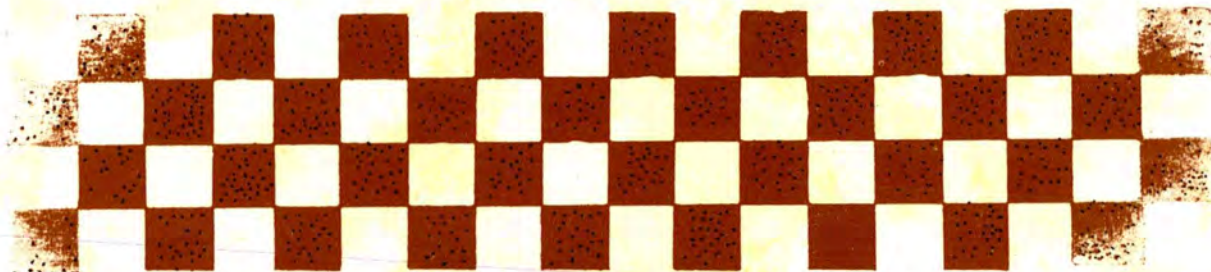

Dark brown
Soft tea character
Lacking pungency
at first soluble
or suspendable
in hot water
becoming insoluble

PLATE I — The fermentation process diagrammatically represented.

THE PRINCIPLES OF TEA MANUFACTURE

astringent character and the modified astringency may be what we call pungency. The process lends itself to simple diagrammatic representation as shown in Plate I.

The progress of fermentation may be followed to some extent by extracting leaf at various stages of manufacture with water and ethyl acetate. The initial extract from withered leaf is high and as much as 48% of its dry weight may dissolve in water.

Figures showing changes in solubility are given in Table I.

Table I. *Changes in solubility of oxidizable matter during processing*

SOLVENT	SOLUBILITY % DRY MATTER			
	Green leaf	Withered leaf	Lightly fermented	Fully fermented
Water	46	48	37.5	33
Ethyl acetate	19	21	11	8

The solutions obtained in both cases from green leaf and withered leaf are very pale in colour. With lightly fermented leaf both water and ethyl acetate extracts are bright and have a strong red tinge. With over-fermented leaf the water extract is reddish and dull, some of the over-fermented "polymers" being in suspension rather than in solution. The complex polymers appear to be more or less completely insoluble in ethyl acetate.

Normal teas are bound to contain a mixture of unfermented, properly fermented, and over-fermented juice and there is, therefore room for a wide variation of character of liquors even when the green leaf is uniform. On the average, however, the better liquors contain more of the ethyl acetate soluble compounds as shown in Table II.

Table II. *Water und Ethyl acetate soluble substance in high-grown and low-grown teas*

	PERCENTAGE SOLUBILITY OF DRY MATTER IN	
	Water	Ethyl acetate
Six high-grown teas Average sale price Rs. 2.19	35.2	10.4
Six low-grown teas Average sale price Rs. 1.91	35.4	8.8

The aims of tea manufacture must, therefore, be to wither and roll the leaf so as to get the major part of the oxidizable matter oxidized to the red intermediate compounds and to stop the fermentation by firing before too much condensation has taken place.

Other substances present in the leaf, however, have considerable influence on this equilibrium point.

TEA MANUFACTURE IN CEYLON

Caffeine.—Caffeine is a colourless, slightly bitter compound which is present in tea leaf to the extent of 2.5 to 4.5 %. It is an important constituent of beverages such as tea, coffee and cocoa and is responsible for their stimulating properties. During manufacture it does not appear to undergo any changes of fundamental importance but it is possible, indeed probable, that it forms an association with the desirable intermediate products of oxidation, and may protect a part of them by precipitation, so that they do not undergo further changes to complex polymers. The product of the association between oxidation products and caffeine is soluble in hot water, but separates out on cooling of tea liquors as "cream". A heavy "cream" on cooling is a sign of a high concentration of red condensation compounds in the liquor. This is one of the aspects of tea manufacture requiring further investigations.

Pectins.—Pectins are present in many leaves and fruits and are responsible for forming the jelly in jams. Pectins set to jelly when mixed with sugar and made acid. When pectins are broken down to pectic acid they form a jelly more readily and the presence of sugar is not essential so long as they are acid. Tea leaf commonly contain up to 7% of pectins and stalk of particularly rich in these substances as shown in Table III.

Table III. *Pectins in tea leaf. (An example from a single analysis)*

Material	Total pectin as % of dry weight
Bud	4.94
1st leaf	6.09
2nd leaf	4.68
Stalk	7.59

The pectin content of leaf appears to undergo quite rapid changes and there are indications that sunshine may cause a rapid increase in pectin content. Different clones have also been found to vary widely in their pectin contents.

Tea leaf also contains an enzyme called "Pectase" which splits pectins into pectic acid and methyl alcohol. The methyl alcohol evaporates from the leaf during fermentation and firing. The pectic acid liberated by the enzyme makes the initially acid tea leaf slightly more acid during fermentation and the conditions in the fermenting leaf are favourable to jelly formation. If fresh green tea leaf is mixed with half its weight of water and then made into a paste in a pulverizing machine it will, if kept warm for a few hours, set into a jelly.

The enzyme pectase responsible for this reaction requires a higher temperature (120°F) for maximum activity and is relatively slow in action at normal rolling and fermenting temperatures but pectic acid is quite certainly formed during fermentation, the amount depending on the amount of pectin in the leaf and the activity of the enzyme (pectase).

The amount of pectase present in tea leaf also increases rapidly in sunny weather and observations made on four different T. R. I.* clones showed that pectase activity doubled itself between two pluckings in sunny weather following a dull period.

* The Tea Research Institute of Ceylon.

THE PRINCIPLES OF TEA MANUFACTURE

The effect of Pectic Acid formation on the Oxidation of Oxidizable Matter.—Since the enzyme responsible for the oxidation process described earlier is so dependent on an oxygen supply, the development of a jelly in, or on, the leaf during fermentation is obviously liable to upset the fermentation or oxidation of the oxidizable matter which gives rise to the condensation compounds responsible for the major character of the liquor. Evidence of interference with oxidation has been obtained by keeping freshly rolled and crushed leaf in a vacuum for a preliminary period, in which pectase, which does not require oxygen, can carry on converting pectins into pectic acid. When the oxygen supply to the fermenting leaf is restored it does not take up as much oxygen as exactly similar samples which have been allowed to ferment normally.

The conversion of pectin to pectic acid is a slower process than the oxidation of oxidizable matter. It is important, therefore, that the oxidation process should proceed as quickly as possible before the pectic acid slows down oxidation. The more pectin there is in the leaf, the greater the importance of speed of fermentation in the earlier stages of rolling and fermentation. At least in the case of high quality leaf, which is comparatively rich in pectins, the oxidative part of fermentation must be speeded up as much as possible by hard rolling.

Both the results of research and practical experience in St. Coombs factory with high quality leaf and cool conditions suggest the maxim;—“Don't mess about in the rolling room.” Understanding of the principles of manufacture now enables us to outline the aims and objectives of manufacture in a fairly simple form.

1. Wither to a point where the juice is still mobile, but not moist enough to result in a wet “water-logged” mass.

2. Remember that the juice is “wrung” out of the leaf and that the wringing action cannot be applied to small particles of leaf. The early stages of rolling must twist, rather than cut, the leaf.

3. The first roll must, therefore, give a tight twist designed to wring out the juice as quickly as possible and get the fermentation started.

4. The oxidation proceeds most speedily at a temperature of 80–90°F provided there is an ample supply of oxygen. So long as there is good circulation in the roller and the leaf does not form into a water-logged mass which is simply torn up by the battens at table level—akin to rubbing a tightly squeezed handful over a nutmeg grater, conditions in the roller are very favourable to fermentation. It is a mistake, therefore, to make the first roll too short or turn out too much dhool.

5. Dhool*, as distinct from eroded particles of leaf, eventually twists off from the leaf and when present in the roller in any quantity begins to impede or clog the rolling action. It must then be sifted out. It is important that it should not be over-cooled—it should be sifted out and spread on the fermenting tables with warmth from the roller still in it. Roll-breaking must be simple and rapid. A roll-breaker which does not give reasonably even dhool of the correct size in one operation should be put right without delay, or cast on the scrap heap where it cannot waste money.

The roll-breaking can also at times serve a useful purpose in cooling over-heated bulk and will be discussed more fully in a later chapter. By the time the dhool is spread on the fermenting tables it is never too warm.

*Finer leaf twisted off and broken up during rolling. The machine used in separating it is called a roll-breaker.

TEA MANUFACTURE IN CEYLON

6. Once dhool is separated and spread, the main danger is that fermentation will be slowed down by too low a temperature. The warmth inherent in it, provided it has not been over-cooled during roll-breaking, is preserved by thick spreading. It still, however, requires oxygen and also gives off some carbon dioxide which, being a heavy gas tends to accumulate, making a compromise essential. Spreading the fermented leaf 2 inches thick seems to be satisfactory.

7. Although the leaf should be fired as soon as fermentation is complete, there is a large degree of latitude. The pectic acid formed in later stages of fermentation seems to afford protection against rapid over-fermentation. The main danger lies in insufficient oxidation of the oxidizable matter.

When leaf is very rich in pectin it appears to tolerate very long periods of fermentation with remarkably little ill effect, except when flavour is present. When flavour is present in the leaf, hard rolling and short fermentation give the best results. If flavoury teas are greenish in character they are readily forgiven.

Aromatic Constituents—The characteristic odour of tea, which develops during fermentation and which is so strong in the firing room, is most probably due to volatile aromatics or "essential oils." Various research workers have steam distilled large quantities of tea and obtained only very small quantities of volatile oils. In one instance only 4 ounces of oil were obtained from the distillation of over two tons of tea. It is most probable that the development of aroma during fermentation is at least partly enzymic and that flavoury teas are merely teas which, through climatic conditions such as low temperature, drought and wind, develop more volatile oil during growth than is usual in normal climatic conditions.

The facts are simply that very little is known about flavour and little can be gained by theorizing. We are fairly certain that aromatic constituents even in flavoury Ceylon leaf are present in only minute amounts. When we attempted to study the volatile constituents we obtained quantities of methyl alcohol liberated from pectins by the enzyme pectase and this first drew our attention to the importance of pectin—pectic acid. Steam-distillates of tea always smell strongly of tea and so do preparations of pectin and oxidizable matter even when purified. We can only at present assume that the aromatic smell of the preparations is due to minute traces of very powerful aromatic substances present as impurities, that the oils do distill in steam and that very large quantities of leaf will have to be distilled before any appreciable amount of aromatic substances can be isolated.

Infused Leaf—The colour of the infused leaf is regarded by the trade as a factor of some importance in judging the quality of a tea. Whether this is entirely justifiable is open to some doubt, but in the ordinary course of orthodox manufacture, examination of infused leaf can give useful information. For instance, if the dry leaf is apparently small but appears as large pieces on the lid of the pot after cupping it is certain that it has been well and tightly twisted.

The actual colour of the infused leaf is, curiously enough, due to a side reaction which cannot apparently have any direct effect on the quality of the liquor and which probably can be misleading. When the enzyme oxidizes the catechins or oxidizable matter the first product is a highly reactive compound known as a quinone. It may be said to be similar to hydrogen peroxide and is in fact an oxidizing agent in its own right. As

THE PRINCIPAL OF TEA MANUFACTURE

explained earlier it is the initial step in the condensation reaction. The quinones almost instantly react either together or with unchanged oxidizable matter, but if, during the course of their brief existence they come into contact with the green colouring matter in the leaf known as chlorophyll, they oxidize it to a brown pigment and the green colour of the leaf changes to brown.

We are quite certain that chlorophyll is oxidized by quinones because it has been studied under controlled conditions in the laboratory. We also know that if the magnesium molecules in chlorophyll are substituted by copper the chlorophyll does not oxidize. If copper salts are injected into a tea bush some will find their way into the chlorophyll molecules and the leaf on fermentation will give a coloury liquor with a bright green infusion. This had to be taken into account in blister blight spraying as excessive absorption of copper through the leaf will affect infusions, but there is no danger if the Institute's advice is closely followed. We have recently been accused of being dictatorial in our attitude but, if advice is to be straight-forward and simple and not confused by complicated explanations it has to be given as a firm directive and this is an example of such a case.

Exactly what happens in the tea leaf during fermentation, and just how many factors affect the colour of the infused leaf is a matter of imagination based on the known fact that chlorophyll is oxidized by enzyme plus oxidizable matter when all these come into contact in the presence of air. Presumably when the juice is wrung out of the tissue some air gets into the tissue to replace the juice. This air will bring about oxidation in the tissue as distinct from on the surface of the tissue. Rolling is a prolonged process and as the leaf circulates and twists some kneading action will take place. Air may, therefore, be pumped in and out of the leaf mass to some extent and up to the time pectic acid seals off the spongy leaf tissue, oxidation of chlorophyll in the leaf will continue.

Pieces of flaky leaf which have been broken off before been uniformly twisted and bruised, will remain green and show up in the infusion. Leaf from non-fermenting or slow-fermenting type of bushes, bruised leaf which has quickly dried out in withering will also be evident by its greenness in the infusion. If the fermentation has been insufficient, or sometimes in quality leaf rich in pectin where the pectic acid has been developed quickly thus sealing off the leaf tissue early in the course of fermentation, the oxidation of chlorophyll may be incomplete and the whole infusion will have a greenish tinge.

The brightness and dullness of infusions is difficult to explain, but the probability is that thin leaf tissue containing the oxidized chlorophyll will appear brighter than thick or coarse leaf tissue. Other pigments which are normally masked by the green chlorophyll show up only when leaves die, for example "autumn tints" will also show up when the chlorophyll is oxidized. The amounts of these pigments vary in different types of leaf and will undoubtedly affect the colour and brightness of infusion.

If leaf rich in pectin and pectase develop pectic acid exceptionally quickly as appears to happen in some T.R.I. clones, the infusion may be very green but the liquor can still be very coloury.

The position is therefore, that although the colour of an infusion may be a useful guide to faults in plucking and manufacture, it is by no means an infallible indication of liquoring properties. If a liquor is bright, coloury, and strong, the fact that the infusion is greenish should not affect

TEA MANUFACTURE IN CEYLON

the value of the tea. The chlorophyll remaining in the leaf will slowly, like museum specimens of green leaves, change to a brown colour on storage.

Maturation and keeping quality.—There is some evidence about the factors which affect keeping quality, and this may be related to known fact about the chemistry and biochemistry of tea, making it possible to advance a reasonable explanation.

First of all let us deal with the evidence. Storage experiments carried out many years ago, all of which were eventually evaluated by tasters, showed that moisture and air were the two things which affected both maturation and deterioration. A high moisture content in the presence of air may after a few days or, at the most, weeks, allow some slight improvement in stored teas. The slight improvement is followed by rapid deterioration, and if the moisture content is above 6% deterioration is rapid especially so at high temperatures. If the teas are well sealed deterioration is far less rapid.

Dry teas (3-4% moisture) tightly packed in tightly sealed containers, which prevent the ingress of fresh air supplies, will keep almost indefinitely. We have kept teas in sealed glass bottles for over ten years and had good reports on them when opened. It is very difficult to obtain evidence about maturation because of standards for comparison, but dry, well-sealed teas do not show any rapid improvement such as that obtained in the presence of considerable amounts of moisture. Teas kept for a long period do, however, acquire a mature character and any greenness in the infusion slowly disappears. The mature character is smoothness as opposed to a rawness or rasp. Deterioration brings about a softness in which character disappears and the liquors become dark brown and dull or muddy.

From what we know of the chemistry and biochemistry of fermentation it appears that oxidation continues in the dried tea. We have attempted to measure the oxygen consumed during storage and relate it to change of tasters' opinion, but the technical difficulties are very considerable and the task demanded more time and energy than could be spared from more practical pursuits. Once the oxygen is used up in a well packed chest of dry tea, probably being replaced by carbon dioxide because we have found considerable quantities of carbon dioxide in dry tea, oxidative change become very slow indeed. In hermetically sealed containers or vacuum pack it is almost completely arrested. We have heard tea-tasters claim that they can detect changes in teas packed in sample tins which have been opened, cupped, closed again for a few weeks, and then opened again. Their observations agree completely with all that is known and suspected. In fact tea in a domestic "Caddy" which is opened several times a day and is kept in contact with more fresh air as the level of the tea goes down, very obviously deteriorates. The effect is very marked with coffee which loses quality in a few days after roasting and grinding, unless vacuum packed. Even so when the vacuum pack is opened the coffee goes off very quickly.

The keeping qualities of tea are very good compared to other dehydrated products, for instance, carrots and potatoes, which lose all their flavour unless packed in carbon dioxide or nitrogen filled tins. Roasted coffee is commonly packed in vacuum, but tea keeps quite well in tightly packed, moisture proof packets. The large amount of oxygen required to bring about a small change in the oxidizable matter probably accounts for this and so long as it is kept dry and the air supply is limited, the

THE PRINCIPLES OF TEA MANUFACTURE

discernible change in quality in the period before it is used up is unimportant.

It is very probable that pectic acid mixed with the reddish-yellow condensation products which give tea most of its character dries to an impermeable varnish which prevents further oxidation to the brown relatively insoluble polymers of over-fermented leaf. When the moisture content of leaf is high, penetration of oxygen will probably be more rapid. Where the moisture content is really high, say above 8% moulds and bacteria are able to multiply and cause further changes. Tightly twisted tea leaf is very much akin to a strip of paper which has been dipped in gum, rolled into a cylinder and dried. The penetration of air and even moisture into the interior of the cylinder will be very slow. Pectic acid may, therefore, play a very important part, not only in fermentation, but in keeping quality and perhaps also preservation of flavour.

Summary and Generalized Interpretation:—The principles of orthodox tea manufacture are:—

1. To wither the leaf to a stage where the juice is concentrated and tacky, but can be wrung out by a twisting motion. When the juice is sufficiently tacky the rolled mass can be kept well aerated.

2. Enzymes in the leaf take up oxygen from the air and use it to oxidize the colourless, bitter astringent oxidizable matter in the juice.

3. Reddish-yellow compounds with a pungent rather than astringent or bitter taste are formed by the oxidation. These reddish-yellow compounds are eventually oxidized to dull brown compounds which becomes less soluble in hot water than reddish-yellow compounds, and are soft or lacking in pungency.

4. The oxidation is most rapid at 80-90° F.

5. Another enzyme which is most active at 120° converts pectin present in the leaf to pectic acid which being of a jelly-like nature impedes the uptake of oxygen.

6. The oxidizing action which is the more rapid of the two reactions must be accelerated by hard rolling and warmth in the early stages of rolling so that the action is largely completed before the formation of pectic acid from pectin, which is a slower reaction, begins to impede the oxygen supply necessary for oxidation. Pectic acid performs a useful function in slowing down oxidation in the later stages of fermentation thus preventing rapid over-fermentation.

Liquor Characters—Since it is not possible in the orthodox tea roller to wring all the juice out of the leaf, some unfermented oxidizable matter will be present in the liquor. The wringing out process is spread over a considerable period of time so that some juice will get highly oxidized and some only slightly oxidized.

The main, and most desirable, character will be imparted by the juice which is oxidized to the reddish-yellow compounds which give a bright sparkling liquor. When these desirable compounds are present in high concentration the liquor will be bright, strong, coloury and probably pungent.

Traces of unfermented juice add to the pungent character, but if present in excess will give a raw greenish character and the liquor will be astringent rather than pungent.

Small amounts of highly oxidized juice will give a more coloury liquor with a smooth mellow character, but excess will dull the colour of the liquor and give it a soft character.

CHAPTER 2

INTRODUCTION TO THE PRACTICE OF TEA MANUFACTURE

It was seen in the first chapter that for the production of black tea certain chemical changes are necessary, and these are brought about by expressing the cell contents of the leaf on to its surface and oxidizing them in the presence of oxygen. The fundamental objective in the manufacture of black tea is to produce these changes and all the processes other than sifting are primarily concerned with this purpose.

The next requisite in tea manufacture is to make the appearance of the finished product conform to the traditional requirements of the trade. The criterion of successful manufacture by present standards is to strike a balance between these two objectives, some times sacrificing one for the other, depending on individual circumstances, which of course, are chiefly governed by elevation.

The liberation of juice from the leaf can easily be accomplished by crushing it and thus bringing it to a condition which will enable the necessary chemical changes to take place, but since the appearance of the product, when treated in this way, is much below trade standards, the leaf undergoes two special treatments. These are withering and rolling.

The former consists in reducing the moisture content of the leaf and changing its physical condition so that it may be twisted without breaking up into flakes. The process is really a preparation of the leaf for the next stage of rolling, which twists it and extracts the sap from it at the same time.

The so-called "fermentation" then takes place which, it must be pointed out, is solely responsible for the development of those characteristics which appeal to the palate of the consumer of black tea. It may be considered, therefore, to be the most important process in tea manufacture. Since practically everything done in tea manufacture is linked with fermentation in some way or the other it is essential to have a rudimentary knowledge of the theory of this process, and the reader should carefully study the first chapter in order to be able to gain some understanding of the objects of each process in manufacture.

When fermentation has proceeded to a point where it is judged to be complete, the leaf is fired. A certain amount of fermentation takes place at this stage and some further chemical changes apparently occur which induce a mellower character in the tea. Fermentation is effectively checked, provided the tea is fired to a sufficiently low moisture content, and the product made capable of preserving the characteristics it acquires at the time of firing.

After firing, a little oxidation continues in the dried tea and this is referred to as post-fermentation or maturation. This may result in tea losing some of its astringent character and becoming 'mature.' There appears to be some relationship between this property of the tea and its moisture content but it has not been definitely established.

The moisture content however, has an important bearing on the keeping properties of a tea. Deterioration takes place rapidly when tea is stored with a high moisture content or allowed to gain in moisture

INTRODUCTION TO THE PRACTICE OF TEA MANUFACTURE

content by faulty methods of storage. Being hygroscopic, tea absorbs moisture readily and this emphasizes the necessity for packing tea in really moisture proof containers. Tea can be kept almost indefinitely when stored under such conditions.

The grading operation is chiefly influenced by market requirements, and requires careful and judicious attention. It is as important a stage in tea manufacture as the processes which precede it.

The approach to Tea Manufacture—Whether or not tea manufacture can fairly be called a science, or whether it still remains an art, is a matter of controversy. The fact that the control of the various stages of processing is largely empirical does not necessarily establish manufacture as an art. In the past there has been much confusion in manufacturing practices, which can with advantage be eliminated, since to make any process appear unnecessarily complicated is to obstruct success. The reasons for the successive treatments are now becoming clearer and with understanding will come more precise control and standardization.

Until mechanical and chemical control of all the stages of tea manufacture is very greatly improved there must be an element of skill in the processing of tea and, since uncontrollable factors such as weather and growth conditions will always influence the final product, complete standardization is clearly impossible. Nevertheless, there is no reason why considerable improvements should not be possible in the control of processing designed to bring out the best quality which is inherent in the leaf. Some of the present "rule of thumb" methods which have come to be accepted as standards such as a 20 hour wither or a 30 minute roll are really the result of lack of development in tea machinery, and must be accepted for the time being, but with reservations.

If the whole subject of manufacture is examined it will be seen that, in essentials, the methods employed in different factories vary but little. Yet, very rarely are the teas the same. For a long time it was believed that these differences were primarily due to some special skill in tea making but this is not always the case. Whatever methods are employed in the factory most of the characteristics in a tea arise from the properties of the green leaf. These may be good or bad or mediocre, but the fact that they play an important part should be recognized if a correct approach is to be made to tea manufacture.

It is quite impossible to introduce in the factory any particular characteristic unless it is originally present in the green leaf. Hence we have the familiar expression 'tea is made in the field,' a statement which goes to show the important contribution made by the quality of the leaf towards the character of a tea. In other words, it predetermines the extent to which the characteristics of a tea could be developed in the factory.

The main characteristics of a tea by which its market value is judged, are appearance, colour, strength, pungency, quality, flavour and infusion. Seldom or never, does a tea possess all these features at their optimum and however carefully manufacture may be carried out one character is more often than not developed at the expense of another. It is essential, therefore, to find out first what particular characteristic or characteristics the tea from a particular area should possess to make it more valuable and then develop them to the maximum possible extent, if they are present. It is pointless, for instance, in the low-country* carrying out a method of manufacture that is specially meant to conserve flavour. At

*Estates whose factories are situated below 2,000 feet.

TEA MANUFACTURE IN CEYLON

higher elevations, when, due to certain conditions of growth, the buds are lacking in hairs, it is just a waste of time to try to produce 'tip.'

Until such time estates are planted with clonal material, the intrinsic properties of which can be determined, the only possible method of approach is to develop those characteristics brought about by elevation and season. For example, high-grown quality of up-country* teas is an attribute peculiar to the higher elevations and cannot be reproduced in the low-country. In the low-country climatic conditions tend to induce more colour in a liquor. The appearance of the made tea is also in complete contrast to that made up-country, and is a natural contribution from high jat leaf with its juicy sap. If the best is to be made of the leaf in these two regions it is quite obvious that two distinct types of manufacture are required.

Under the wide variation of conditions obtaining in Ceylon no two estates can be expected to follow identical methods of manufacture or produce identical teas even at the same elevation or in the same district because no two estates will have the same type of leaf or the same type of equipment or for that matter the same type of tea-maker. Whatever the fact may be, most misleading conclusions may be drawn if, as already pointed out, no account is taken of the properties of the leaf, whether they are present naturally or induced by external factors. It is necessary to mention the more important of these factors if the effect of any technique is to be more clearly understood.

Pre-Manufacture Influences.—Elevation can be considered one of the major influences affecting the general quality of tea. In association with elevation are climate, seasonal variations and all other things peculiar to the district in which the tea is grown. Temperature, wind amount of sunshine and rainfall—all these decide the quality of the finished product through their influence upon growth and on the properties of the leaf.

The marked difference between the quality of up-country teas and those from the low-country is mainly due to climatic conditions. It is quite impossible to obtain high-grown quality in teas grown at the lower elevations, and this has been clearly borne out by experimental manufacture of low-grown leaf at higher elevations. Though the teas improved to some extent as a result of more favourable temperature conditions the 'coarseness' of a low-country tea was not eliminated. The subtle high grown quality was absent. Conversely, Nuwara Eliya leaf manufactured at an elevation of 4,500 feet lost the distinctive Nuwara Eliya character.

**Jat of the leaf is another important factor, which not only varies from estate to estate, but from field to field or even bush to bush on an estate. Perhaps it is not known that the characteristic black appearance of a low-country tea results from the natural properties of the leaf and not from any special method of manufacture. From an area of a particular field on St. Coombs estate it was possible to produce a tea with practically all the features associated with a low-country tea. It was the natural contribution from high jat leaf with its juicy sap. Had most of the low-country areas been planted with low jat, brownish teas would have

*Estates whose factories are situated at 4,000 feet and over.

**Jat is used to distinguish the two extreme types of hybrid tea found in Ceylon, 'low' describing the tea that more closely resembles the China plant with its small, leathery leaves, and 'high' the big leaf, juicy type.

INTRODUCTION TO THE PRACTICE OF TEA MANUFACTURE

been produced and no skill in manufacture would have been able to make them black.

Dominant characteristics in the tea liquor such as "greenness" and "maltiness" are now known to arise mostly from the intrinsic nature of the leaf. For a long time it was thought that some peculiarity in manufacture was the cause, but this is usually not the case and more often than not, unusual features in a tea have their origin in the leaf long before it is plucked from the bush.

Age from pruning, age of the bush, method of pruning and length of the plucking round are some of the many other important factors that affect the quality of the product. The question whether manure exerts a major influence is still controversial, but experimental evidence to date shows that manure, whether organic or inorganic, and in large doses or small, has very little apparent effect on quality. Undoubtedly, manuring will exert an indirect influence if the standard of plucking is altered as a result of quicker growth following heavy manurial applications. On the other hand, hard banji* resulting from shortage of manure or delay in plucking adversely affects quality and is the cause of many a problem in manufacture. Very little is known about the influence of shade on quality of tea but since heavy shade results in an undue development of stalk the possibility of a deterioration in quality induced by such changes in the growth of a bush cannot be overlooked.

It will thus be seen that besides climate and jat, field operations exert a considerable influence on the quality of the finished product. Of those that could be controlled, there is no doubt that the biggest single factor is the standard of plucking. To understand its effect it is helpful to know something about the chemical and physical composition of a tea shoot.

The Composition of Green Leaf—Some most important constituents of green leaf which affect the liquoring qualities of a tea are measured as "total oxidizable matter" or T.O.M. as explained in Chapter 1. Another important constituent is caffeine. The range of variation in the different parts of the shoot is shown in Table IV, the figures given for tannin equivalent being a measure of the T.O.M.

Table IV. *Values **of the tannin equivalent (catechins) and caffeine in various parts of the shoot. (Calculated on dry matter).*

Part of shoot	Tannin equivalent (Catechins)	Caffeine %
Bud and first leaf	20	4
Other leaves	11-14	2-3
Stalk	4-9	1
Hard stem	2-4	Less than

**T.R.I. Bulletin No. 9

The effect of the standard of plucking is very well illustrated by these figures and needs no elaboration. In conjunction with the physical composition of a shoot the effect is better seen. Table V shows the effect of standard of plucking on the composition of a pluck.

*Banji denotes a shoot in which active growth has temporarily ceased.

TEA MANUFACTURE IN CEYLON

Table V. *Percentage composition of plucked leaf*

	Good plucking standard	Normally recognized standard
Two leaf shoots, (comprising bud and 2 leaves, and banji bud* plus 2 leaves) }	75%	50%

*dormant, undeveloped bud.

Considering that if plucking is coarser, the percentage by weight of two leaf shoots will be much less, it is not difficult to see why good teas cannot be made from flush with a predominance or third leaves and stalk.

It is outside the scope of an account of tea manufacture to discuss the many factors that influence a plucking standard and how best they can be controlled. The important relation that exist between the standard of plucking and the manufactured product should always be remembered if a fuller understanding is to be obtained of the various stages through which the green leaf passes in manufacture.

Before discussing these it will not be out of place to refer to the outturn of made tea to green leaf. The prevalence of tea thefts has focussed attention on this figure and it may be useful to examine all the possible factors which affect outturn.

The outturn of Made Tea to Green Leaf—In the first place it may be well to remember that local condition, have a direct bearing on the percentage outturn of made tea to green leaf. A statement which is perfectly true of one estate may be entirely inapplicable to another. In view of the astonishing variety of conditions from estate to estate one must be very cautious in drawing conclusions from records of percentage outturns. Even data from neighbouring estates where conditions would be thought similar might prove an unreliable guide for the checking of outturn figures.

The popular belief is that outturn of made tea is dependent only on the moisture content of the green leaf, or the percentage of dry matter it contains, which varies not only according to the weather, but also with the age from pruning. It is not perhaps realized that the following factors can also affect it :—

- (a) the standard of plucking,
 - (b) the degree of wither,
 - (c) the period of wither,
 - (d) the temperature of withering,
 - (e) the moisture content of the fired tea.
 - (f) storage conditions,
- and (g) final firing.

Factors (a) and (b) influence the outturn indirectly in that the outturn of refuse tea bears a close relation to them. Coarse plucking, or under-withered or over-withered leaf, when broken up unduly in the rollers reduces the percentage outturn of good grades and the total crop in consequence.

INTRODUCTION TO THE PRACTICE OF TEA MANUFACTURE

Withering results in a loss of dry matter, equivalent to about 1% on total outturn in a very long period of 48 hours since the leaf uses up some of its starch to provide the necessary energy for respiration. There is reason to believe that at high temperatures, the losses would be greater.

The other three factors (*e*), (*f*) and (*g*) obviously affect the outturn directly. For every extra 1% moisture in the made tea, the percentage outturn is increased by 0.25% more or less.

Even should it be possible to determine the exact loss or gain in outturn due to the above mentioned factors it is quite impossible to express quantitatively the correlation between rainfall and outturn. For example, the same amount of rainfall may be recorded on two successive days and assuming all other conditions of manufacture are the same, it does not follow that equal percentage outturns will be obtained on both days. If on one day a brisk shower of rain is followed by sunshine, and on the other a thin drizzle is experienced throughout, it is obvious that the condition of the plucked leaf brought in for manufacture on the two separate days will be entirely different, because the former will contain less moisture than the latter. The number of hours of sunshine, intensity of rainfall, and the time at which it rains have all to be taken into account when considering the effect of climatic conditions on the moisture content of green leaf. Rainfall by itself is a most misleading guide; the way it is distributed hourly is what matters most.

The moisture content of green leaf, according to records kept at St. Coombs, varies from about 69% to about 83%. That of dry leaf free from surface moisture may be anything between 69% and 76%. That is to say, the made tea outturn from *dry* leaf, plucked directly from the bush instead of giving a 25% outturn, as generally believed, may vary from 31% to 24%. It is a fallacious belief therefore that leaf free from surface moisture should give a 25% outturn.

Leaf in its condition of maximum wetness can contain as much as 30% surplus water and even should the moisture content of wet leaf be determined it will be impossible to say with any accuracy how much of that water is due to surface moisture alone. A consideration of these observations and the variation of the moisture content of dry leaf itself clearly shows the folly in making arbitrary deductions from wet leaf in order to get a flattering outturn.

No system of allowance for surface moisture should therefore, be permitted in a factory. The following example will perhaps be convincing enough to put an end to the practice in some estates of not recording the actual weight of green leaf received for manufacture. Assume two lots of leaf, differing by only 1% in their moisture contents, one containing 78% and the other 79% moisture. Both will look very much alike as regards the degree of wetness of the leaf although their respective outturns will be 22% and 21%. Now if a constant outturn of say, 23% is to be shown, 4% will have to be deducted from the former and 9% from the latter. But if 9% is deducted from the former instead, the outturn will be over 24%! What is the result if only 5% is deducted owing to misjudgment? It will mean an outturn of 23.2%, or to make the figure more impressive, an error in judgment of only 1% in moisture content is equivalent to nearly 1% of the crop.

These figures are certainly impressive enough to warrant the consideration of the whole question of percentage outturn in a sober light. Far too much attention appears to be paid to a figure, which besides being

TEA MANUFACTURE IN CEYLON

subject to adjustment is most difficult to check. When it is remembered that even throughout the day leaf arrives at the factory with varying moisture contents, the outturn figure provides information of little value. The sooner, therefore, less importance is attached to outturn figures, the better.

Treatment of Green Leaf—Tea manufacture can be said to begin from the time the leaf is plucked, because much can happen to it to affect the quality before it is withered.

One of the prime requisites for preservation of quality is undamaged leaf. When leaf is bruised, cells are ruptured, and fermentation starts so that those portions of the leaf that are damaged are considerably over-fermented long before manufacture proper begins. They are also apt to dry up during withering. The greatest care in handling of the leaf is therefore very necessary while it is being plucked, during its transport and after its arrival in the factory.

Heating of the leaf must also be avoided since a chemical change somewhat similar to fermentation comes into play. Leaf should, therefore, not be rammed into containers, or exposed to the sun for too long a time. It should be delivered as quickly as possible at the factory and after arrival spread on the withering tats with the least possible delay.

The preceding account should form the real basis for an understanding of the various processes of tea manufacture, and it now only remains to know the meanings of the commoner terms used to describe a tea. This will be discussed in detail in Chapter 13. For the time being, however, a definition of the main characteristics should suffice.

Main Characteristics of a Tea—(a) *Quality*.—In its broadest sense, this term is used to describe all the characteristics of a tea, inclusive of its appearance. It is, however, commonly used to denote the presence of some desirable characteristic in the liquor. When used in this sense, it serves to distinguish the fundamental difference between teas produced in the low country and those from up-country. To all intents and purposes it can therefore be said that low-country teas possess very little of the so-called quality when compared with high-grown teas. To avoid confusion regarding the correct interpretation of this term it can be taken to mean general excellence in liquor and not degree of excellence.

(b) *Appearance* —The term is self-explanatory. This characteristic is usually gauged by the amount of stalk and fibre a tea contains and the degree of twist it possess. The colour of the made tea and evenness in its size are also taken into consideration when assessing appearance.

(c) *Colour*.—Denotes colour in liquor, which may be red or brown, varying in intensity. A coloury liquor is one having good colour and is bright red and clear. When wanting in colour a liquor is described as light not to be confused with thin, a term used to indicate a liquor lacking in strength.

(d) *Strength*.—Denotes concentration of substances contributing to taste and need not necessarily be associated with colour. Light liquors can be strong, and over-fermented liquors weak.

(e) *Pungency*.—This is the vaguest of all the terms. It can perhaps be best detected by a tickling sensation in the salivary glands, similar to the effect of smelling a sour orange or lime. It must not be confused with "greenness" or "bitterness." It is a most desirable characteristic which is accentuated at certain times of the year.

INTRODUCTION TO THE PRACTICE OF TEA MANUFACTURE

(f) *Flavour*.—This is a characteristic prevalent only at higher elevations and under certain conditions. It is a rare attribute induced during period of fine weather accompanied by cold nights, and dry winds. Rain destroys it.

(g) *Infusion*.—Means really the infused leaf. The trade attaches much importance to it, although sometimes it bears no relation to the properties of a liquor. The colour of the infused leaf and its degree of evenness are the criteria. A bright, even infusion is considered to be a valuable asset. A dull infusion is brownish in colour, and may be due to some fault in manufacture or an inherent property. For similar reasons an infusion may be green in colour.

CHAPTER 3

THERMOMETRY AND HYGROMETRY

This short chapter is devoted to giving a general idea of that branch of the science of heat which is relevant to the technique of tea manufacture. All the processes are influenced by temperature and humidity, and it is advisable to have some general knowledge of the principles involved.

Temperature is defined as a number denoting the hotness of a body according to some arbitrarily chosen scale. An instrument used for measuring temperature is called a thermometer.

Hygrometry is concerned with the measurement of the amount of water vapour in the air, or to put it more simply, its moisture content. The degree of saturation is called relative humidity. Air which cannot absorb any more moisture has 100% saturation or 100% relative humidity. Completely dry air has 0% saturation or 0% relative humidity.

Relative humidity is the ratio of the weight of water vapour in a given volume of air to the weight required to saturate it at the same temperature, and is expressed as a percentage. For example, if a certain volume of air contains 2 lb. of vapour, while the amount it would contain, if it were saturated, is 8 lb., the relative humidity is $\frac{2}{8} \times 100 = 25\%$. If it originally contained 4 lb., the relative humidity would have been $\frac{4}{8} \times 100 = 50\%$. If it had 8 lb. instead, the relative humidity would have been $\frac{8}{8} \times 100 = 100\%$. Thus it will be seen that the figure for percentage relative humidity is a measure of the drying capacity of the air as well, the lower it is the higher its capacity for taking up more moisture.

Another important point to note is that the maximum amount of water which a given volume of air is capable of holding is dependent on the temperature. For example, air at a temperature at 90°F when saturated contains twice as much water as air when saturated at 66°F. It follows therefore that if we have two lots of air, one at 90°F and the other at 66°F containing the same amount of water, the percentage relative humidity of the former will be half that of the latter. The instrument used to determine this ratio is called a hygrometer.

The simplest instrument is the wet and dry bulb hygrometer which consists of two thermometers round the bulb of one of which is loosely wrapped some muslin or cotton wool which dips into a small vessel of water placed immediately below. This thermometer measures the temperature of saturated air. The other thermometer registers the temperature of the air, at a particular degree of saturation. The difference between the readings of the two thermometers can by reference to tables be converted into relative humidity. When air is saturated or at 100% relative humidity, both thermometers read the same.

A rough explanation of the principle of the wet bulb is as follows:—When evaporation goes on from the surface of the wet bulb, its temperature is lowered, the more rapid the evaporation the lower the wet bulb temperature. When no evaporation takes place the two thermometers will read alike. The difference between the wet and the dry thermometers therefore depends on the humidity of the atmosphere. If the air is dry, the difference is large; if the air is moist, the difference is small;

THERMOMETRY AND HYGROMETRY

and, if the air is completely saturated, there is no difference. By the use of tables constructed (vide page 142) percentage relative humidity is numerically estimated.

For satisfactory results to be obtained from hygrometers of this type it is most important that the following conditions be observed:—

- (1) they must be kept scrupulously clean,
 - (2) the observer must have his eye directly opposite the point read,
 - (3) the reading must be taken as quickly as possible,
 - (4) the hygrometer should be freely exposed to the atmosphere, and not hanging against a wall or pillar,
 - (5) the water container should always hold sufficient water for the wick to dip freely, and the wick should be as short as possible,
 - (6) the muslin should be renewed from time to time and never allowed to remain in a dirty state,
 - (7) clean water should always be used,
- and (8) hygrometers should never be exposed to direct sunlight.

If outside readings are required hygrometers should always be placed in the shade or in a specially built screen. Suspending them below the factory eaves is not advisable owing to the radiant heat from the galvanized sheets.

By the correct use of hygrometers in a factory, control of withering and fermenting is achieved to some extent. Another place where one will be found most useful is in the sifting room.

It is advantages for a factory to possess as many hygrometers as possible, but they will not make any difference to manufacture if they are looked upon merely as instruments for recording temperatures. A planter who had been having difficulties with manufacture, and who had been advised to get some hygrometers supported this statement by the observation: "I have festooned the factory with the b—y things and they have not made a ha'porth of difference to my manufacture."

The hygrometric properties of air are dealt with more fully in Appendix A.

CHAPTER 4

WITHERING

If attempts are made to roll fresh leaf in the conventional tea roller without the normal withering preparation, it breaks up into small flakes and the resultant tea is unacceptable to the tea trade; or at least, they are not prepared to pay normal price for such a product. The juices from the broken leaf which contain the full content of moisture are diluted and drained away from the broken leaf very freely, introducing a practical difficulty and losing potential strength of liquor. In spite of the mess and the loss of valuable juice the cells in the pieces of flake are not properly bruised the flake does not ferment evenly.

It is obvious, therefore, that since the conventional tea roller is designed to twist or wring juice out of tea leaf, the leaf must be conditioned to stand up to such treatment. The main objects of withering are therefore, to reduce the moisture content of the leaf, to concentrate the juices, and bring the physical condition to a "rubbery" state in which it will stand twisting without breaking up into flakes. The two objects are intimately connected because the leaf is only liable to flake when the cells are turgid, that is to say, full of moisture and liable to burst when roughly handled. When the cells are only half full they are less liable to burst and the leaf becomes rubbery or flaccid. By way of a parallel example we may take a fully blown up or half inflated rubber balloon. The fully inflated balloon is very liable to burst whereas the half inflated balloon will stand up to an astonishing amount of punishment.

During withering, especially if the period is long, the cell walls may undergo some changes and so long as the leaf remains alive, that is to say, continuous to give off carbon dioxide, food reserves are used up. In mobilizing these reserves some chemical changes will take place. Only in long withers, is there any evidence that chemical changes during withering have a marked effect on subsequent processing.

As explained in Chapter 1, aeration is a most essential part of the rolling and fermenting processes and, if the rolled leaf turns into a wet, water-logged mass in the roller, the supply of oxygen for the oxidation of oxidizable matter is impeded.

One of the first essentials of withering is, therefore, to get a correct physical condition which will not only allow leaf to be rolled without breaking up too quickly, but which will also prevent the juice from running out of the leaf. There are several tests to show when leaf is well withered. Withered leaf when squeezed in the hand forms into a ball. The feel of well withered leaf is something like that of a crumpled soft handkerchief. It has a drooping appearance and lacks the lustre of fresh leaf. The stalks can also be bent without their breaking, and, if the fingers are pressed into the leaf, the impression is clearly visible. The smell of the leaf is a misleading guide for judging the wither. These empirical methods are the best means of judging the extent of wither, but like all systems which rely on human agency for the result, cannot always be entirely depended upon.

For efficient manufacture one primary consideration is uniformity, because standardization of any operation is thus facilitated. A constant moisture content in the withered leaf will go a long way in achieving this

WITHERING

objective. This could be determined by suitable moisture determination apparatus, but the sampling error is so large that the method cannot be recommended. The simplest method available of checking personal judgment is to determine the outturn of made tea to withered leaf.

Percentage outturn of Made Tea to Withered Leaf—This figure is obtained by dividing the weight of made tea by the corresponding weight of withered leaf and multiplying the result by 100. For example, if the weight of made tea is say 500 pounds, and the weight of withered leaf is 1,100 pounds, the percentage outturn of made tea to withered leaf (MT/WL%) will be $\frac{500}{1100} \times 100 = 45\%$. A 45% outturn is roughly equivalent to 55% moisture in the withered leaf.

For all practical purposes a moisture content of 55% can be regarded as representing a good medium wither. It is quite impossible to lay down a figure which would suit all factories, but a range of 50 to 60% moisture is permissible, the higher moisture content being more suitable for low-country factories. Leaf containing more than 60% moisture (equivalent to 40% outturn made tea to withered leaf) is generally insufficiently withered, whilst leaf with less than 50% moisture (equivalent to 50% outturn made tea to withered leaf) has had its withering carried so far as to make it difficult to wring out its juices in rolling. In case of doubt as to what figure will give the best results a 45% outturn is recommended for trial.

Withering down to a constant moisture content is, of course, impracticable. Even the greatest care and best judgment will fail to get the same degree of wither daily, but it is possible to work within certain limits. A reasonable variation for consistent results is 2 to 3 per cent.

Expressing a Wither—It is still the practice on some estates to measure a wither in terms of the outturn of withered leaf to green leaf, described as "percentage wither." It would certainly be a convenient way of doing so if the moisture content of green leaf were constant, but percentage wither provides no information whatsoever about the physical condition of withered leaf. All that it does is to indicate the amount of moisture lost in withering. Of what use is this figure unless the moisture content of the green leaf is known?

Green leaf varies in moisture content within wide limits. It can be as low as 70% on a dry day, or as high as 83% on a wet day. It follows therefore that if say a 50% wither is taken for two such lots of leaf the actual state of wither of the leaf will be entirely different in the two instances. To be precise, the moisture content of the withered leaf in the two cases will be as shown in table VI.

Table VI. *Relationship between moisture in green leaf and withered leaf at fixed percentage wither*

Moisture content of green leaf	Moisture content of withered leaf (%wither 50)
70%	40%
83%	66%

If the moisture content of the withered leaf is to be the same, it is obvious that less water will have to be evaporated from the drier leaf,

TEA MANUFACTURE IN CEYLON

and more from the wetter leaf. That is to say, the percentage wither of the latter will have to be less than the former. Table VII shows how percentage wither is affected by extra moisture in the green leaf. To illustrate the effect two lots of leaf differing only by 5% in their moisture content's have been taken as examples.

Table VII. *Effect of condition of green leaf on % wither*

	Weight of green leaf lb.	Evaporation lb.	Weight of withered leaf lb.	% wither: i.e.- WL GL x 100	Moisture content of withered leaf%
Dry leaf (75% water)	500	225	275	55	55
Wet leaf (80% water)	500	275	225	45	55

Table VIII shows the wide variation in percentage wither which might be obtained in a tea factory.

Table VIII. *% wither required to give same degree of wither.*

Moisture content of withered leaf	% WITHER REQUIRED FOR FRESH LEAF CONTAINING	
	70% water (very dry)	83% water (very wet)
50% (very hard wither)	60	34
55% (medium wither)	67	38
60% (very soft wither)	75	42

Accordingly, if percentage wither is used to indicate the degree of wither a correction will have to be applied for the surface moisture of wet leaf which may be as much as 30% of the gross weight when very wet. Since external moisture on leaf is a very difficult thing to assess any system of deduction is most inaccurate for checking withers. The percentage outturn of made tea to withered leaf, on the other hand, is quite independent of the variations in the condition of the green leaf, and measures the degree of wither in the only rational way possible.

Appendix B gives the relationship between outturns.

Degree of Wither—For the purpose of describing a wither, some standard is necessary otherwise words like 'soft' and 'hard' will have no meaning. In order to simplify this issue, the degree of wither is defined in relation to percentage outturn of made tea to withered leaf. Figures given in table IX have been obtained as a result of careful observations on different degrees of wither in relation to the physical condition of the leaf.

WITHERING

Table IX *Relationship between outturn of made tea to withered leaf and type of wither.*

Outturn of made tea to withered leaf	Approximate moisture content	Type of wither
40 %	60 %	Very soft
42 %	58 %	Soft
45 %	55 %	Medium
48 %	52 %	Hard
50 %	50 %	Very hard

Leaf with an outturn of less than 40% can be considered under-withered and leaf with an outturn of over 50% over-withered.

If these figures are to serve as a guide it is highly important that the wither be as even and uniform as possible. A mixture of under-withered and over-withered leaf may very well show a satisfactory outturn but divorced from all relation to the degree of wither it is supposed to represent. Such uneven withers have more often than not led to misleading conclusions regarding the effect of the degree of wither.

Generally speaking, a wide range in the degree of wither is permissible in manufacture, so long as evenness of wither is not ignored. The question whether harder withers or softer withers are preferable depend largely on the elevation of the factory and the method of rolling followed. In the low country, where lighter rolling is practised because of the importance of appearance, a soft wither is permissible. At higher elevations, where appearance of the made tea is not so important a feature as the liquoring properties, hard rolling is necessary for which too soft a wither is undesirable.

With regard to the effects of moderately light and hard withers in general, evidence suggests that there is no noticeable difference between the two. Whatever differences are observed are entirely due to the manner in which the leaf is rolled. If hard withered leaf is rolled, for instance, with no increase in pressure, less juice is wrung out and the resulting liquor will naturally be lighter than soft withered leaf suitably treated. This question will be discussed more fully in the next chapter on rolling, because a clear insight into the effect of the degree of wither is only possible when it is considered in conjunction with rolling.

In deciding what wither is best the nature of the leaf is even more important than elevation. A coarse pluck with a predominance of tough leaf and stalk cannot, for example, be hard withered because the tender leaves would be apt to get brittle. Good leaf, on the other hand can be given a full wither without the danger of any part being over-withered.

In a similar way, mixed jat introduces considerable difficulties in procuring a constant degree of wither, but this does not matter so long as leaf is neither under-withered nor over-withered. However uniform a jat may appear to be, it is beyond human ingenuity or the most perfect control to get that degree of uniformity where every flush is withered to the same moisture content. What is exactly meant by evenness of wither in a practical sense is not that each flush is withered to the same degree, but withered to a rollable condition. This is really the essence of good withering.

TEA MANUFACTURE IN CEYLON

Mechanism of Withering— In an evaporation process water escapes in the form of vapour, and this is brought about by heat, the rate at which it is supplied controlling the rate of evaporation. Heat used for such a purpose comes from the air and the wet body, and the changes that take place continuously during the process of water evaporation are:—

- (1) cooling of the air,
- (2) increase in the humidity of the air,
- and (3) cooling of the wet body.

Rate of evaporation decreases as the air becomes more saturated, and no water will evaporate when the air becomes fully saturated. If evaporation is to continue from a wet body it must have a continuous supply of heat.

Green leaf behaves like a wet body during the withering process, but does not lose its water as a free surface does since most of the moisture is evaporated through the stoma or "pores," and a certain amount through the epidermis (the outer layer of the leaf). The water from the interior has to travel to the surface before it can evaporate. The rate at which leaf loses moisture is therefore affected not only by external conditions but by its structure as well.

In the case of stalk, a part of its moisture passes to the leaves from where it is evaporated. For a good standard of plucking this is very small. The leaves and buds lose moisture quicker than the stalk, but their rate of withering is not affected by the presence or absence of stalk. The results from an examination of this question are given in Table X.

Table X. *Rate of withering of the main parts of a shoot*

	PERCENTAGE MOISTURE		
	Leaves & buds	Stalk	Whole shoot
Before withering	76	85	79
After withering	48	62*	50

*Withered separately—66% moisture

Note—The stalk was 18% by weight and the period of wither 20 hours.

The main factors that influence withering are:—

- (a) damage to green leaf,
- (b) condition of the leaf, whether wet or dry,
- (c) type of leaf,
- (d) standard of plucking,
- (e) thickness of spread.
- (f) condition of tats,
- (g) period of wither,
- and (h) drying capacity of the air,

Damage to Leaf—The effect of bruising has already been referred to in connection with the chemical changes that follow. As a result of

WITHERING

the cell constituent being mixed with enzymes, premature fermentation is started. Leaf which is damaged also dries out during withering and causes loss of both appearance and potential liquoring quality. A soft wither will help to minimize the effect, but it is virtually impossible to prevent it altogether.

Blister blight causes the same mechanical damage and badly blistered leaf cannot be hard withered.

Damaged leaf is easily recognized after withering by its discoloured appearance. The brownishness it acquires sometimes gives the impression that it is caused by too high a temperature, but this is generally not the case. If leaf that is damaged is carefully examined it will be found that only those parts which have been bruised are affected. Undamaged leaf retains its green colour.

Condition of the Leaf—Owing to variations in climatic conditions leaf may arrive at the factory in a dry or wet condition, as a result of which, the moisture which has to be evaporated from the leaf varies considerably from day to day. Hence withering is prolonged when leaf is wet, and unduly prolonged if steps are not taken to remove surface moisture as rapidly as possible.

Surface moisture on the leaf exists as free water and evaporates more speedily than the moisture contained in the leaf. Withering really commences after surface moisture is removed. If atmospheric conditions are too humid, recourse to hot air from the driers is necessary. Withering fans should be set going and hotter air than is advisable for surface dry leaf may be used. When the leaf has arrived at the condition when withering may be said to have started, the temperature should be lowered.

The rapid removal of surface moisture is strongly recommended for another reason as well. Wet leaf contains more bacteria on its surface than dry leaf, and bacteria are known to be one of the causes of dull infusions and soft liquors.

Type of Leaf—Rate of withering is appreciably influenced by the type of leaf or "jat," size of leaf, and its general composition. The resistance offered to evaporation of water varies with the amount of water in the leaf. For example, flush from tipping fields, or from shoots allowed to run up have thick stalk but immature leaf, which loses its moisture more readily on withering than the stalk. If an attempt is made to wither such leaf to low moisture content, the leaf is liable to dry out leaving the stalk soft. To evaporate the maximum amount of moisture from the stalk, and at the same time prevent the leaf from getting brittle, a slow and long wither is necessary.

It may be wondered why so much importance is attached to the withering of the stalk. One reason is that extra moisture in stalk makes proper rolling difficult. Another reason is that the rolling of underwithered stalk tends to strip off the outer skin, thus making more prominent the familiar 'reds' and 'stalk' in the made tea.

Standard of Plucking—The influence of the standard of plucking is partly associated with the texture of the leaf and partly with its moisture content. Stalks contain more moisture than the leaf, and leaves and stalk lose moisture at different rates during withering. Tender leaves wither faster than coarser leaves. A mixed pluck, or a coarse pluck, will thus result in a very uneven wither.

TEA MANUFACTURE IN CEYLON

The presence of tough banji and hard, single leaves makes the control of withering more difficult. These leaves hardly wither at all and at the end of the withering period may be so green as to upset one's judgement when estimating the degree of wither. Therefore, the more uneven or coarser the pluck, the larger the variation in the degree of wither. It is unnecessary to stress how important it is to pay careful attention to plucking when it is realized that even under homogeneous conditions of withering, variations in the moisture content have been found between different pieces of flush from *one bush*. A good, uniform standard of plucking will minimize the variation in the withered material.

Thickness of spread—Leaf can be withered satisfactorily with a rate of spreading up to as much as 1 pound per 5 square feet, but withering is slowed down. Thick spreading also increases the unevenness of the wither. It is perhaps not realized that by spreading leaf too thinly uneven withers can result as well. Extremely thin spreading is wasteful in space and should be resorted to only if conditions are unfavourable to the procuring of a wither in a reasonable time. It is sometimes necessitated by wet leaf, but even then, a rate of spreading of 1 pound to 20 square feet should be ample. If sufficient air supply is available, thicker spreading is permissible.

The deciding factor should be the drying capacity of the air used. The whole question of how thickly leaf should be spread depend on this. Under normal factory conditions the area on which a pound of green leaf can be spread to give good withers, may vary from 10 square feet to 15 square feet. The prevailing idea that the best results are obtained with a spread of 1 pound to 15 square feet has nothing to support it. The important consideration is the air supply. For estimating withering space requirements, however, this figure may be used to allow for unexpected increases in crop or fickleness in weather.

A fixed spreading rate cannot be adopted in any factory. Apart from the wide variation in the condition of the leaf that is received, the lofts themselves do not provide completely uniform conditions for withering. Their position in relation to the direction of wind and bulking chambers has to be carefully noted. Besides, air speeds in lofts are seldom uniform.

Condition of Tats—Sagging tats are the cause of a great deal of trouble in withering. Tats must always be maintained in a taut condition, and should under no circumstances be left slack. When pockets are formed rate of withering is appreciably retarded. It is not a laborious business retensioning hessian and the care and attention given to withering tats will undoubtedly be repaid many times over.

Period of Wither—This is governed to a large extent by the amount of crop, equipment, type of tea required and working hours. There is no such thing as a normal withering period. What is normal to one estate may be abnormal to another. This is because the period of wither has a direct bearing on the liquoring properties of a tea.

Long withers give more coloury teas than short withers, and this colour is gained at the expense of quality. This is an established fact. The longer leaf is withered, the more quality is lost. Flavour reacts in a similar manner. It is thus a simple matter in so far as colour, quality and flavour are concerned, to gain some control over these characteristics by varying the period of wither.

WITHERING

It must be remembered, however, that temperature is inter-linked with period. If quick withers are obtained by employing high temperatures, colour may be developed at the expense of quality. Low temperatures in association with long periods of wither may have the same effect. The optimum period to be decided on must therefore be related to withering conditions and their influence on the finished product.

When quality and flavour are at a high level, there is no advantage in holding back a wither, but it should not be rushed. Flavoury teas can be produced in a withering period of as long as 20 hours. If it could be shortened without the use of heated air so much the better. When these two characteristics are virtually absent, withering can be prolonged, but should not exceed 48 hours because this may lead to sourness. If neither of these characteristics is marked a normal withering period of about 20 hours will probably give optimum results unless experience has shown that either extreme has been found to give the most satisfactory results. It may be shorter or longer according to convenience in factory organisation and still not greatly affect the character of the tea.

Drying Capacity of Air—This factor embraces temperature, hygrometric difference, volume of air and movement of air.

It is generally believed that the evaporative capacity of air can only be increased by raising its temperature. This is not the case. The volume and speed, if increased, can be far more effective than a rise of a few degrees in the dry bulb temperature. This is why natural conditions at comparatively lower temperatures than those employed in artificial withering sometimes produce quicker withers. The process is accelerated when the hygrometric difference is larger and air movement is rapid.

In estimating the drying capacity of air it is not enough to take note of the dry bulb temperature only. No matter how high the dry bulb may be, if the difference between the dry and wet bulb temperature is small, the relative humidity of the air will be so high as to cause comparatively little evaporation. If the air is stagnant the wither will be extremely slow.

It is thus evident that, if large volumes of moving air are supplied for withering, the necessity for very high temperatures does not arise, providing the hygrometric difference is large enough to wither the leaf to the degree necessary in manufacture.

High temperatures in withering are harmful to quality. This is another established fact, but the statement may be misleading unless the effect of both the dry and wet bulb temperatures is clearly understood.

Withering Temperatures—Green leaf at the beginning of the withering process behaves exactly like a wet body and has a temperature approximately equal to the wet bulb temperature of the air. As withering proceeds the leaf becomes physically less wet and its temperature increases above the wet bulb. It will be seen therefore that the temperature of the leaf depends partly on its moisture content and partly on the wet bulb temperature of the air.

From this phenomenon it may be concluded that leaf, towards the end of a withering process, is generally at a higher temperature than during the initial stages of its process, all other conditions being equal. It follows therefore that, if the temperature of the leaf is to be kept as low as possible, both wet and dry bulb temperatures should get lower and lower while moisture is being removed from the leaf. This explains

TEA MANUFACTURE IN CEYLON

why the use of heated air at the beginning of the withering process is preferable to employing it in the later stages.

A fact that must be recognized from what has been just said is that although leaf is a wet body, or partly wet body, it tends to follow the wet bulb temperature of the air only so long as water is being evaporated from its surface. If no evaporation takes place, as may very well happen in a badly ventilated loft, the leaf assumes the *dry bulb temperature* of the air.

The rate of evaporation from the leaf is therefore as important as the wet bulb temperature. The greater the evaporation, the cooler the leaf. The ideal conditions for withering are accordingly low wet bulb temperatures and large hygrometric differences with an ample supply of moving air.

At certain times of the year during the height of the flavoury season atmospheric conditions approach this ideal. In the day-time the hygrometric difference may be greater than 15°F, and the wet bulb temperature as low as 50°F. At night, though the hygrometric difference is smaller the temperatures are lower. During periods like this, if natural withers only are taken, the temperature of the leaf rarely rises above 50°F. To reproduce these conditions at other times of the year by artificial means is extremely costly. Heated air has perforce to be used when atmospheric conditions are unfavourable.

While it is easy to heat air, it is impossible to prevent the wet bulb temperature from rising. The wet bulb temperature rises approximately 1° for every 3 to 4° increase in the dry bulb temperature. This means that big hygrometric differences can be achieved only if the dry bulb temperature is raised unduly high. It is incorrect to assume that an increase of say 20° in the dry bulb will result in a 20° bigger hygrometric difference. The later will be much less.

The following example illustrates the effect heating air:— Assume air on a very wet night to be practically 100% humid at a temperature of say 65°F (dry); 65°F (wet). If heated to 75°F, the wet bulb temperature will be about 68°F—a 7° hygrometric difference. If heated to 85°F, *i.e.* a 20° rise in the dry bulb, the wet bulb will go up as high as 72°F.

If the air can be conditioned cheaply so as to raise the dry bulb temperature without raising the wet bulb, there need not exist any misgiving about the influence of high temperatures in withering on quality. It is because the wet bulb also rises in the ordinary process of heating air that care must be taken not to employ too high a temperature.

The temperature above which quality is impaired has not yet been determined, but in view of the considerable risk in withering leaf at high temperatures, particularly if they are maintained too long, the best advice that can be given is to create conditions at night as close as possible to what natural conditions should be in the day-time for procuring a reasonable wither. To keep temperatures as low as possible and still not seriously reducing the drying capacity of the air a large volume is necessary. With adequate fan capacity it is generally feasible to keep the temperatures of heated air down to about 75°F with a satisfactory hygrometric difference as well. Dependent on outside conditions, temperatures even lower than this can be employed without prolonging the wither unduly but only if large volumes of air available.

Natural Withering—What exactly is meant by a natural wither? To say that it is a wither obtained by keeping loft windows open for

WITHERING

natural breezes to play over the leaf, does not truly define it. If outside air is very still, but of a certain temperature and humidity in suitable for withering the leaf, it can be made to move through the lofts by the use of fans. Circulation of outside air in this manner improves the conditions necessary to enable the leaf to be withered, but since no extra heat is supplied this form of withering can also be regarded as natural. A natural wither as distinct from an artificial wither is therefore one where the air is not conditioned.

It is a common notion that natural withers give better results than artificial withers. What is the reason which has led to this belief? The explanation is simple—the abuse of the system by raising the temperature unduly high. It has already been pointed out that such conditions need not be created, since moderate temperatures are practicable. The critical factor in artificial withering is the volume of air available, and it is this, in fact, which puts a premium on natural withering.

The second aspect of natural withering, apart from the unlimited supply of air available is the generally lower temperature of the air. The outside air is not always sufficiently dry to be suitable for withering and when such conditions exist artificial withering is always preferable.

When to use heated air is the next question. Misguided by false notions that leaf cannot be withered unless the hygrometric difference is about 7°F, many estates have got into the habit of using hot air indiscriminately. If there is continuous air movement, natural withers can be obtained with lower hygrometric differences in a reasonable time. It is possible with a difference of as low as 4°F between the wet and dry bulb temperatures to wither leaf without unduly prolonging the period. The necessity for artificial withering arises when the hygrometric difference is lower, but this should not be regarded as a counsel of perfection. It should only serve as a guide since so many other factors are involved. Some of these are the movements of air in the lofts, the thickness of spread, the condition of the leaf and the period of wither aimed at.

Artificial Withering—There are two distinct systems. One in which the air always travels in the same direction through the lofts, and the other in which its direction can be reversed whenever required. The former is now almost obsolete, but a passing reference may be made to it in order to bring out the advantages of the reversible system.

The unidirectional system, as it may be called, suffers from a serious disadvantage. As a result of the air moving in one direction only from the middle of the factory, withering is more marked where the warm air enters the lofts. The drying effect from one end of the loft to the other becomes more uneven with each degree rise in the temperature. Under such conditions uniform withering is out of the question. If instead of pushing the air by boosting fans situated in the bulking chamber, suction fans placed at the gable ends of the factory are operated to draw the air through the lofts, the unevenness of the wither becomes still more marked. For one thing, hot air and cold air will not properly mix in the bulking chamber and for another, the air will tend to move in well defined streams. Another and very serious shortcoming of such a system is that the air is discharged into the atmosphere when it reaches the gable ends. Excess heat may on occasion be thus wasted.

In the reversible system this surplus heat is usefully employed in doing further work by passing the air through another loft. By using

TEA MANUFACTURE IN CEYLON

air in this manner it can be made to travel from one loft to another in either direction. Any unevenness of wither resulting from air flowing in one direction is therefore minimized.

Although reversal of the air in artificial withering helps to counteract unevenness to a high degree, the leaf at the end of the loft furthest from the bulking chamber is apt to be less withered than that spread nearer the bulking chamber. This can be balanced by adjusting the thickness of spread. Too long a loft aggravates these difficulties because it must be remembered that as heated air travels over the leaf it absorbs moisture. The dry bulb temperature from bank to bank will thus be continuously decreasing. If evaporation is rapid the temperature gradient will be so steep as to result in the air being practically 100% humid long before it reaches the last bank. In such circumstances the air will have to be heated to a very high initial temperature to be effective, but this in turn will bring about more unevenness in the wither no matter how frequently air is reversed.

The most even withers are produced when air has to traverse short distances. They are also produced when the temperature drop through the loft is not marked. High initial temperatures with very big hygrometric differences must therefore be avoided, but in doing so, the drying capacity of the air is reduced. This can be counter-balanced by increasing the volume of air. The fact that many factories are obliged to employ high temperatures in withering, points to inadequate fan capacity. From what has been said so far the only approach to the problem is to have larger volumes of air. It is uneconomical, of course, to have an excessive volume of air with too small a hygrometric difference. In any case, the amount of air is limited to some extent by the speed at which it travels through a loft, but if adequate fan capacity is available, there is no necessity for excessively high temperatures. The figures given in Table XI may be used to estimate fan requirements in relation to crop and size of drier.

Table XI. *Fan requirements in relation to crop and size of drier.*

Drier for withering	Total fan capacity, Cubic feet per minute	No. of bulking chambers	Average daily green leaf intake—lb.	Annual crop made tea—lb.
3'	50,000 to 80,000	1	5,000	300,000
4'	80,000 to 120,000	1	8,000	500,000
5'	120,000 to 180,000	1 or 2	12,000	750,000
6'	160,000 to 240,000	2	16,000	1,000,000

It must not be inferred that more fan capacity is not desirable, but anything lower would necessitate excessively high temperatures.

The capacity of hot air for useful work may be judged by careful observation of the hygrometric readings. Hygrometers are absolutely essential for control and should not be looked upon merely as instruments for conveying some idea of the humidity of the air, for they have to serve a far more important purpose. If, however, they are to function properly, in the capacity they are intended for they should be placed in the correct positions. It is obvious that the temperature of the inlet air should be taken in front of the first bank of tats and not behind it, and that the temperature of exhausted air should be measured directly opposite the

WITHERING

window through which the air is discharged. When air is led from the loft to another below or above it, the hygrometer should be placed near about the point where the hot air reverses itself.

The optimum hygrometric difference of the heated air is related to both the dry bulb temperature and the amount of air used. It really depends on how high the dry bulb temperature can be raised. This in turn depends on how much air is heated and on what temperature the drier is being operated at. Whatever the circumstances, it is not advisable to exceed 80°F (dry bulb). Higher temperatures are permissible when leaf is wet. In practice it will be found that more often than not a temperature not exceeding 75°F provides good withering conditions. A hygrometric difference of at least 5°F is attainable at this temperature. But it is necessary to stress once again that hygrometric differences are only a partial indication of the drying capacity of air. If the air supply is deficient a hygrometric difference of as much as 10°F might be found necessary. The fact must not be lost sight of, however, that a bigger hygrometric difference brings in its train a higher dry bulb temperature, a higher wet bulb temperature and more unevenness in the wither. If, therefore, temperatures are to be kept as low as possible large volumes of air are called for.

The rate of evaporation is indicated by the hygrometer at the other end of the loft. If the hygrometric difference is found to be less than 3°F after the air has travelled the full length of the loft, little will be gained by passing it through another. If hardly any drop in the dry bulb temperature is noted, very little evaporation is taking place. If air is discharged into the atmosphere with a hygrometric difference of over 4°F heat is just being wasted.

The next aspect of artificial withering to be considered is the conditioning of the air to the required degree. This is done by mixing hot air from the driers with the cold air from the atmosphere. The connection between the volume of air delivered by the driers and that by the fans has, therefore, to be taken into account. The temperature of a mixture of air depends on the proportions in which they are mixed together. For example, if hot air at 160°F is mixed with cold air at 60°F in equal proportions the temperature of the mixture will be approximately $\frac{160+60}{2}=110^{\circ}\text{F}$. If the proportion is 1 to 10 the temperature of the

mixture will be $\frac{1 \times 160 + 10 \times 60}{1 + 10} = 69^{\circ}\text{F}$. It will thus be seen that

bulking of air in different proportions gives a wide range of dry bulb temperatures. The wet bulb temperature is not so easily calculated since this depends on the moisture contents of the quantities of air that are mixed together. It is outside the scope of this chapter to discuss the psychrometric changes that take place, but it may be useful to know what relationship exists between the final wet and dry bulb temperatures. If the drier is not being used for the firing of tea at the time the air is bulked the wet bulb temperature rises 1° for every 3 or 4° increase in the dry bulb temperature. If the hot air from the drier exhaust is used while tea is being fired, the wet bulb temperature goes up by about 2° or more.

Adjusting the conditions required for artificial withering is consequently not a difficult task. As a rule, it will be found that no matter what outside temperature conditions obtain, an increase of about 10°F in the dry bulb is sufficient to give conditions suited for withering purposes.

TEA MANUFACTURE IN CEYLON

It is impossible to lay down any hard and fast rule as to how this should be done, but the following hints may prove helpful in getting the best out of an artificial withering system:

1. If the exhaust air from a drier, during the firing of tea, has to be used, the amount of cold air that has to be mixed with it should be less than that required for an empty drier. Contrary to popular belief, exhaust air from a drier has further drying capacity but the valuable heat from it can be wasted by indiscriminately mixing too much cold air with it.

2. If an empty drier is being used, every effort should be made, whenever circumstances permit, to run it at the highest possible temperature. The drier is much more efficient when working at 200-220° than at 160° F, which is commonly used for withering. If necessary, the fan valve may be partly closed to reduce the volume of air delivered.

3. The temperature of the mixture should be controlled by letting in as much cold air as possible and regulating the fan damper in the drier. This is an easier and more economical form of control than the empirical method of shutting and closing windows opposite the fans or in the drying room.

4. Fans should not be starved of air. The area of air entry should not be less than the area of the fan inlet. Table XII gives the minimum free area required for fans of different sizes.

Table XII. *Area of fan inlet*

Diameter of fan	Minimum area for two fans. Sq. ft.
6'	60
7'	80
8'	100
9'	130

5. Just as important as not starving the fans of air, sufficient openings should be allowed for it to leave the lofts.

6. If the capacity of the withering fans is inadequate the dry bulb temperature of the mixture should be increased, but not higher than 80° F unless withering is likely to be seriously retarded.

7. If a sufficient volume of air is available the lowest possible temperature should be employed, taking into consideration the time at which the leaf is required to be ready.

In a nutshell, the primary aim should be to produce conditions at night approaching natural conditions in the day-time. If these can be achieved, and there is no reason why they cannot be, much better results can be obtained from a process against which a deep rooted prejudice still exists. It is the poorer results that followed from the indiscriminate use of heated air which gave rise to the erroneously held belief that artificial withering is an evil.

The observance of correct temperatures and relative humidities for heated air does not mean, however, that this is the only thing that matters. Certain precautions have to be taken if the best results are to be obtained.

WITHERING

1. Surface moisture from the wet leaf should be removed as quickly as possible by using the highest possible temperature. Generally, driers are being used for the firing of tea at times wet leaf is received and the only source of heat is the drier exhaust. To obtain the maximum temperature the minimum amount of cold air must be admitted, but care should be taken in doing so to see that the fans are not too scantily supplied with air. A part of their demands in such circumstances might be met from the driers themselves causing erratic firing.

2. The loft should always be warmed before wet leaf is spread.

3. Spreading of wet leaf should always start furthest from the bulking chamber.

4. Although the efficiency of most of the present schemes has been considerably improved by boosting the air and reversing it, thicker spreading of leaf nearer the bulking chamber is strongly recommended.

5. However satisfactory bulking of hot air from driers and cold air from the atmosphere may appear to be, there is always a tendency for the conditioned air to attain a higher temperature on that side of the factory on which the drier is situated. The difference in temperature between the two sides of a loft can at times be so great as to result in a marked unevenness of the wither. It can be corrected by admitting more fresh air on the hotter side either through the windows opposite the fans or those adjacent to the driers.

6. If the weather is not too wet, misty or windy, all the windows of a loft should be opened after heated air has been used. At least a few should be opened in any case to reduce the risk of 'hot house' conditions being created.

7. Warm air should not be used to force the wither in the later stages.

If these measures are taken artificial methods can be expected to give approximately as good results as natural withering.

The Withered Leaf—The harmful effects of the bruising of green leaf have been previously stressed. The same applies to withered leaf as well.

If the period between taking the leaf off the tats and feeding it to the rollers is short, whatever damage the leaf sustains in the process of knocking down and collecting is not of any consequence, but the leaf should not be allowed to remain in heaps, because it is liable to get overheated very quickly.

Since over-heating may cause serious damage, the practice of picking coarse leaf before rollers are charged cannot be favoured. Withered leaf is often left lying about in heaps far too long a time. It is also a dangerous practice to knock down more leaf than is necessary for a batch. The rate of stripping should coincide with the intake of the rollers. Overlooking trifling matters like these do often nullify many of the advantages that would accrue from the care exercised in the withering process.

Since stones, gravel and sand find their way in leaf brought into the factory, such material should be eliminated before the withered leaf is sent to the rollers. An ordinary sifter with No. 4 mesh answers the purpose. The cleaned leaf should on no account come in contact with the floor, and in subsequent operations as well care should be taken, to keep leaf off the floor. This is very essential for hygienic reasons.

CHAPTER 5

ROLLING

Present rolling methods are actually a mechanical development of the original hand rolling process, the primary object of which was literally to wring out the juice from the leaf. In carrying out this operation the leaf acquired a twist at the same time, and the trade has since then insisted on this traditional appearance. Undoubtedly, the general trend in trade requirements is towards better liquoring teas, but a black twisted appearance of the final product is still considered a matter of some importance. It can be said, therefore, that if the rolling operation is to be successful by present standards a balance must be struck between appearance and liquor.

Mechanism of Rolling—When leaf is rolled; it is twisted and at the same time slowly broken up. The leaf cells are thus ruptured and their contents brought into contact with the air, to start the chemical changes necessary for the production of black tea. Leaf cells are not easily disrupted in the conventional type of roller because of the inadequate pressure available. Higher pressures may be applied to the leaf by the employment of different rolling techniques, but in this case the objective will be achieved at a considerable sacrifice of appearance.

It will thus be seen that by way of maintaining the appearance which the trade demands present methods of rolling do sacrifice liquor to some extent. All the juices are not liberated from the leaf, and whatever is extracted is also not set free simultaneously. It is for this reason the process takes such a long time. As will have been gathered, the less pressure applied to the leaf the longer will the process take to extract the maximum amount of sap. It will become even more lengthy and laborious if the expression of the sap depends entirely on a wringing action. Breaking up of the leaf by the twisting action will, however, assist in completing the operation in a shorter time. A simple means of doing this is the employment of battens on roller tables.

Batten/Pressure Cap Rolling—Much confusion of thought exists on the subject of the function of battens, their size and shape. Speaking generally, the purpose of a batten is to increase the frictional effect of the table. If a roller table is perfectly smooth and level, for example, hardly any circulation of the leaf will take place. The action is so feeble that prolonging of the period is required to obtain the desired effect. That is why a circulating device is introduced when a table free from battens is employed. It may either take the form of a projection in the centre of the table or a well in the door.

The early types of rollers had concave doors only, with no battens. (See Fig. 1). They gave excellent results, in so far as well twisted leaf was required, but were slow in action. With the progress of time small rectangular battens were fitted on the sides of this hollow (Fig. 2)—the Jackson's battens as they were then called. Better disintegration of the leaf (dhool production) was obtained, but it was not enough to meet the changing requirements of blenders for smaller leaf. The next development was the Reeves' roller table (Fig. 3). The central hollow was replaced by a dish-shaped surface and battens in the centre as well as in the surround. The battens on the door were similar to the Jackson's,

ROLLING

but larger, whilst those in the surround were kidney shaped. These additions resulted in a definite improvement in dhool production and liquor.



FIG. 1. Section of early type of roller table with concave door and no batters.



FIG. 2. Small rectangular batters fitted on the concave door (Jackson's batters).



FIG. 3. Reeves' roller table (dish-shaped) with additional batters in the surround.

In general the older types of roller table and batten arrangements produced large, bold, teas and it was common practice to take as many as six rolls, and even then the big bulk* percentage was as high as 30. A quarter of a century ago, what amounted to a revolution occurred in the tea trade, and the demand for fannings and small B.O.P's began to exert an influence on rolling technique. The development of devices such as batters and projections in the centre of the table where most of the work is done was therefore a logical sequel to the demand for smaller leaf.

The introduction of deeper batters increased dhool production. The Lamont-Michie, M & S and Crescent batters are typical examples of deep batters on a flat table. The fittings on the doors were of various shapes, the most common of which are shown in Figures 4, 5, 6, and 7. They all had one purpose in view, to break up the leaf more quickly and churn it at the same time. These central fittings, though fulfilling the purpose for which they were intended, failed in one respect; they were not entirely standardized to suit all sizes and types of rollers. Much was left to trial and error.



FIG. 4. The Semi-cone (with a vertical section).



FIG. 5. The Domed Cone.

*The largest particles of leaf obtained after roll-breaking of leaf from the last roll; in other words, the final fraction which goes over the roll-breaker mesh.

TEA MANUFACTURE IN CEYLON

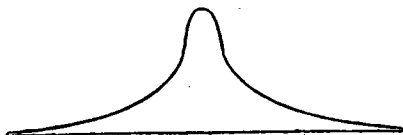

FIG. 6. The Rettle Cone



FIG. 7. The Beehive Cone



FIG. 8. The Plain Cone

The plain true cone (Fig. 8) was finally evolved and is used in many tea factories in Ceylon to-day. Its essential feature is that, by merely altering the angle at its base, dhool production can be varied to suit different requirements. To get the best results from this type of cone the following points have to be observed.

1. The base should be as large as possible, but should allow at least a 1 inch clearance from the jacket at its nearest approach.
2. The angle at the base of the cone should not be less than 35° or exceed 45° .
3. The sides of the cones should be straight.
4. The apex of the cone should be slightly rounded off.
5. The base should be flush with the table. There should be no projecting edges.

If these directions are followed the heights of the cones arrived at for standard rollers will be found to be more or less as under :—

For 28" and 32" rollers	4"
„ 34", 35" and 36" rollers	5"
„ 40", 44" and 45" rollers	6"
„ larger rollers	7"

These cones may be used with any type of batten, but in the case of M & S battens which run into each other, care should be taken to see that no part of the edge of the door projects above the lower level of the battens. It is preferable however to arrange for the battens to merge into the cone. For battens such as the Crescent, which are fitted on an absolutely flat table, extension is not at all necessary.

It has already been stressed that most of the dhool is produced at the centre of the roller table. It must not, however, be forgotten that the battens themselves are effective. Their influence on the outer part of the roller table is relatively small, but those portions situated near the centre have some effect, depending on their design. Some may twist

ROLLING

the leaf, others may cut it. The ideal batten will naturally be one which will first give the maximum twisting effect and then reduce the size of the leaf. Since in practice it will be quite impossible to devise a batten to function in this way, the usual recourse is the pressure cap. The necessary dhool separation is then obtained by adjustment of pressure.

There is a limit, however, to the amount of pressure that can be applied because if the pressure cap is screwed too tightly, circulation of the leaf is impeded, which will give rise to tearing of the leaf. The cone described above, minimizes this effect and so enables more pressure to be applied while retaining the traditional appearance of the leaf.

Still, the fact remains that rolling in the conventional manner will continue to be a lengthy process chiefly because the mechanical aids in a batten-pressure cap roller are designed more with a view to twisting the leaf rather than to breaking it up. If the process is to be accelerated without damage to the leaf it is evident that pressure must be applied in some other way than by means of a pressure cap. The fact that an ordinary cone affected dhool outturn according to the angle at its base, suggested the possibility of employing this principle for subjecting the leaf to more pressure. By increasing the angle to 90° , in other words, reducing the cone to a cylinder (Fig. 9) the pressure generated laterally enabled the pressure cap to be dispensed with. By varying the diameter of the fitting any desired pressure was attained.

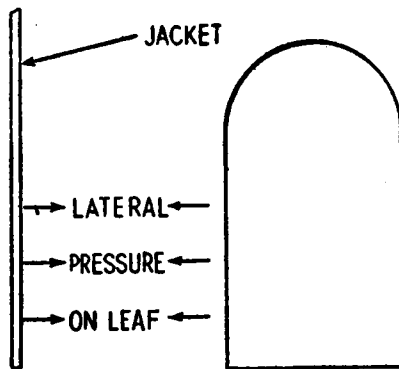

FIG. 9. Cylindrical epicyclic-pressure fitting

This was a great step towards an improvement in the efficiency of rolling. Unfortunately, some estates with the idea of getting the maximum amount of dhool in the minimum of time used fittings with too drastic an action and smashed the leaf. The prejudice still existing in certain sections of the trade towards this form of rolling can be traced to these earlier experiments carried out haphazardly with no thought to the appearance of the leaf. This innovation received a severe setback as a result, but the time may soon come when it will supersede batten-pressure cap rolling. It will not be out of place therefore to give a brief description of this method, now referred to as epicyclic-pressure rolling or E.P. rolling for short. The word "cone" has for some reason or the other been associated with E.P. rolling. This is entirely the wrong word to use because a cone by itself, unless its angle is over 45° , does not set up a horizontal pressure. The use of an ordinary cone without a pressure cap produces relatively very little dhool, that obtained being due to the pressure exerted by the weight of the leaf.

TEA MANUFACTURE IN CEYLON

E.P. Rolling—First and foremost E.P. Rolling must be regarded primarily as a method of saving machinery and labour. No claim is made that it can produce better teas than batten-pressure cap rolling, but it can turn out as good a tea as made by traditional methods if only the fundamentals are grasped. Compared with batten-pressure cap rolling it has the following advantages.

- (1) unrestricted circulation and better aeration of the leaf,
 - (2) elimination of pressure cap manipulation,
 - (3) open top jackets which greatly facilitate charging,
 - (4) employment of bigger charges,
 - (5) shorter rolling periods,
 - (6) bigger dhool production,
 - (7) less number of rolls,
- and (8) rolling under more controlled temperature conditions.

As against these, the only shortcoming that is worth mention is the very slight inferiority in the appearance of the made tea. On a very discriminating market the preference towards battens in this respect may affect values, but on the London Market, which pays less attention to this characteristic, E.P. rolled teas should find a suitable outlet. One feature of E.P. rolling is that owing to the greater lateral pressure exerted throw-out becomes excessive if there is a clearance below the rim of the jacket. A battened table is therefore unsuitable especially in the later stages of rolling when the leaf has been considerably reduced in size. With a plain table on the other hand throw-out can be minimized if the jacket is let down to table level.

The necessity to use a flat table devoid of battens naturally reduces the twisting action on the leaf. Since, it must be remembered, any new method of manufacture must maintain orthodox standards, the success of epicyclic rolling depends on the extent to which leaf can be twisted. To twist leaf rolled in a machine of the type used in the manufacture of tea the essentials are:—

- (1) pressure,
 - (2) circulation under pressure,
- and (3) minimum cutting action.

Circulation alone does not produce a satisfactory twist. For a tight twist to be produced a certain amount of pressure is necessary, but if the pressure is too high, the leaf breaks up too quickly and becomes so small that it is no longer possible to apply a wringing action. Likewise if the leaf is cut by sharp edged battens or similar devices before it has acquired a twist, any method of rolling that follows will not impart a twist to it. The basic requirement for successful rolling is, therefore, first to twist the leaf and then to reduce its size.

In batten-pressure cap rolling this presents no difficulty. Pressure is regulated by the pressure cap. In an epicyclic roller, however, which has no pressure cap, there is no latitude for varying the pressure while the leaf is being rolled, since the central fitting fixes the pressure beforehand. As previously explained, the aim in epicyclic rolling is to accelerate the process by rapid dhool production without smashing and tearing the leaf. The dhool producing capacity of a vertical fitting is dependent on its width and height in relation to the diameter of the jacket and the crank throw of the roller. The amount of leaf and the speed of the roller are other important factors. Failure can result if any one of these is ignored and the wrong type of fitting used.

ROLLING

The cylinder shown in Figure 9 can be adapted for varying conditions, but in the first roll since production of twist and not dhool is the more important consideration, a different type of fitting is preferable (Fig.10).

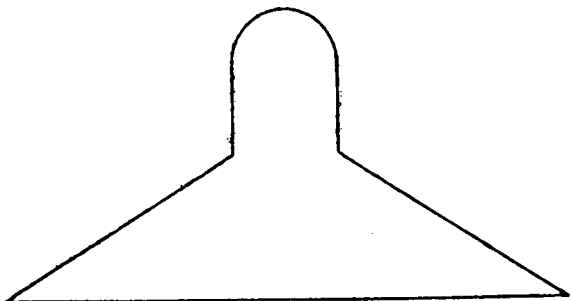

FIG. 10. Cylinder superimposed on a conical base—a suitable E. P. fitting for first rolls.

In this a cylinder is superimposed on a conical base. The latter provides rapid circulation whilst the former supplies the necessary pressure for producing a tight twist in the leaf. The conditions thus set up are similar to those obtained in a batten-pressure cap roller, but with one marked difference; pressure decreases as rolling proceeds. To make this clear it will perhaps be of assistance to indicate that as the leaf goes round and round in the gap between the central fitting and the jacket it is subject to a squeezing action. The bulky material then gradually reduces in size and the "squeeze" is proportionately lessened. If rolling is prolonged it will become hardly noticeable and the leaf will continue to circulate with no useful work being done. It will hence be seen that the fundamental difference between the two types of rolling is that in epicyclic rolling most of the effective action takes place in the first few minutes, whereas in batten-pressure cap rolling it is distributed over the whole period. Accordingly, the former method requires less time to produce the required results, but it must be realized that too rapid an action would be detrimental to the appearance of the made tea. The gap between projection and jacket must be carefully adjusted in relation to charge, because it is the combined effect of the dimension of this gap and the amount of leaf rolled, which chiefly determines the type of tea turned out. This in practice means a larger pressure gap for the first rolls and a smaller gap for the later rolls.

The height of the fitting has also a considerable effect. If too short it has to be compensated for by a greater width. Nothing is gained by making it too long because beyond a few inches above table level its dhool producing capacity is negligible. From experience gained, a height of about seven inches for the vertical face appears to be suitable. In any case, the height is limited by the diameter of the roller door, for if the fitting is too long the door will not be free to open fully.

In view of the many factors involved in E.P. rolling, it is quite impossible to have standard sizes of projections. They will vary according to the conditions obtaining on individual estates and, as they are most sensitive to charge, careful planning of the rolling programme is required. The most appropriate width of a fitting is easily determined by trial, by using an over-sized fitting to start with and skimming its diameter from table level till the desired results are obtained. It is of interest to note that cylindrical fittings may be successfully employed in conjunction with

TEA MANUFACTURE IN CEYLON

battens and pressure caps provided the combined effect is not too severe on the leaf. A large cone sometimes prevents the application of pressure to a small bulk of leaf in later rolls, and in such instances a small cylindrical projection on the door will be preferable (Fig.11). It is most important, however, that it should not be made as large as the dome shaped device shown in Fig. 5.

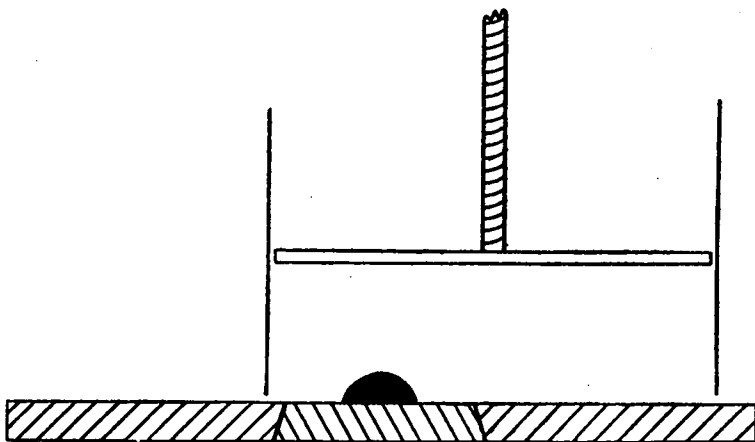

FIG. 11. Small cylindrical projection on the door for use with a batten/pressure cap roller in later rolls.

From what has been written so far it will be seen that rolling is an operation which demands not skill but the right type of machinery, the essential requirement being to maintain traditional appearance, and at the same time bring about the maximum disruption of the cells. An outline of the means of accomplishing this has been dealt with. It is now necessary to consider the other changes that occur when leaf is rolled.

Mechanical Effect.—The disintegration of leaf is accompanied by heat development. A temperature rise must take place because the power put into the roller is largely dissipated as friction between leaf and roller as well as between leaf and leaf. It is said that heat is the enemy of quality, but only excessive heat is actually detrimental to quality, and this will be dealt with later in this chapter. Be that as it may, too high a temperature maintained for too long a period is harmful to quality. Heat development must therefore be controlled.

Apart from heat development, another important change is the reduction in size of leaf. If rolling is continued without a break the dhool impedes the twisting action on the larger leaf. In any event rolling, as it is understood, cannot be carried out on small leaf particles. Leaf in this state forms into a solid mass when pressure is applied. For reasons of efficiency, therefore, rolling instead of being one continuous operation must be a series of operations. At the end of a defined period the leaf is taken out of the roller, passed over a sifter (roll-breaker) and the fine leaf separated from the coarse. The latter is then re-rolled and the process repeated, until the bulk is reduced to the requisite amount. The number of times this should be done and the period of each roll is still a matter of trial and error.

Period of Rolling and Number of Rolls.—Both have to be considered together because it is the total duration of rolling that counts.

ROLLING

The commonest system of rolling in Ceylon tea factories at all elevations is one of four thirty minute rolls, but it is not advisable to be tied down to such a system without first considering the numerous factors which affect the rolling process. The more important of these are:—

- (a) type of leaf,
 - (b) fermenting properties,
 - (c) degree of wither,
 - (d) roller charge,
 - (e) roller speeds,
 - (f) degree of pressure,
 - (g) method of pressure application,
 - (h) temperature,
 - (i) size of dhool and amount extracted,
 - (j) charging interval,
 - (k) type of roller battens,
- and (l) type of tea required.

Leaf can be rolled three times, or six times, or any number of times. Neither can there be any hard and fast rule with regard to the duration of each roll, which can vary from 15 minutes to as much as 40 minutes. One disadvantage, however, in the employment of a very short roll is that as a result of more pressure being required to get the required dhool outturn a greater load is imposed on the power unit. To offset this, smaller roller changes or softer withers will be found necessary. A period of 30 minutes generally meets most requirements and is a convenient basis for drawing up a rolling programme, but number of times leaf should be rolled is dependent on the amount of equipment available and upon the cumulative effects of all the factors just enumerated. In fact it will not be possible to develop a manufacturing technique best suited to the conditions on any particular estate unless each of the factors is examined separately. It is ludicrous, to say the least, to imagine that there can be a set rolling programme for the development of colour, or a standard system for strong liquors, or another for appearance. Any such systems must be envisaged only in the broadest terms.

Type of Leaf—The relation of the type of leaf to the method of rolling is mainly connected with its sap content and the resistance offered by the leaf in rolling to the disruption of its cells. It must be expected that succulent, juicy leaf will not require as much rolling as tough leaf, all other conditions being equal. To all intents and purposes high jat leaf belongs to the former category and low jat leaf to the latter. As these two types of leaf are generally found in the low-country and up-country respectively, two distinct systems of rolling are required. It should be noted, however, at the outset, that quite apart from the extent to which the character of a tea is affected by the system of manufacture adopted, the intrinsic properties of the leaf predetermine the characteristics of the final product. No manufacturing technique can produce any characteristic that is already not in the leaf. When leaf is rolled the juices are liberated and spread over the surface, and these, when dried, assume a dark appearance, giving the tea its characteristic colour. The degree of blackness is governed by the amount of juice liberated and partly by the degree of twist. It is thus not difficult to understand why the teas from the tougher type of leaf grown at the higher elevations are less black and less twisted than those from the juicier type

TEA MANUFACTURE IN CEYLON

found in the low-country. Because of this fact a black appearance has become an indispensable qualification for a low-country tea. It is a misconception to think that it is due to a particular manufacturing technique.

In a high grown tea what matters most is its liquor and its special quality. The so-called high grown quality cannot be reproduced at lower elevations. The chief consideration is the preservation of this quality and rolling methods should be directed on lines having this object in view, and in no way resembling low-country manufacturing methods which are primarily intended to preserve appearance.

Medium grown teas* unfortunately do not possess either of these two characteristics to any marked degree. The logical thing to do, therefore, in the case of estates so situated is to choose a method of rolling that is a compromise between two extremes.

Since appearance is considered to be of so much importance for low elevation teas and tip also a valuable asset, lighter rolling is essential. This must not be taken to imply that leaf should be rolled without pressure. Twist, it was pointed out earlier, requires some degree of pressure if it is to be tight. In the first rolls, however, rolling with very light or no pressure is desirable for one reason only, namely to recover as much tip as possible. The use of a large roll-breaker mesh assists in this operation. After the maximum amount of tip has been removed, the subsequent rolls should be carried out with increasing pressure, the number of rolls depending on the grades required. It may be necessary to run to six rolls for a very high standard of appearance and a high percentage of wiry O.P.

The requirements of upcountry tea are entirely different. Owing to climate conditions and the nature of low jat leaf, tip is only present in small quantities. Light rolling to chase after tip is therefore pointless. The leaf should be rolled relatively hard from the very first roll, but pressure should not be so heavy as to break up the leaf before it is twisted. Appearance also counts in the case of up-country teas though to a lesser extent than low-country teas and should therefore be taken into account. Too severe a batten, which may break up the leaf earlier than desired, must not be used. After the leaf has been twisted, the real breaking down process must commence with the maximum pressure possible. The fancy grades of low-country teas are not required; broken grades are what are needed. The use of smaller roll-breaker mesh is the obvious means. Harder pressure from the beginning of rolling shortens the total duration considerably, making it unnecessary to roll beyond 3 or 4 times, except in unusual circumstances when the leaf has poor fermenting properties, or when poor dhool producing equipment is used.

The two fundamental systems of rolling just described do not hold good for coarse leaf and tough banji. The real difficulty here is with appearance. However carefully rolling may be carried out on such leaf it will never twist properly and flaky tea is bound to result. Stalky leaf makes the evolution of a suitable method still more difficult. In trying to eliminate 'reds' the complexity of the problem is increased because if light rolling is adopted liquors suffer and the tea has an open twist. To get the best out of such leaf it may be rolled hard at the commencement of rolling decreasing the pressure in the later rolls. In other words, instead of increasing dhool outturn as rolling proceeds it is reduced. This must be regarded only as a palliative, as the defects will still show up although

* Teas from estates whose factories are situated between 2,000' and 3,999'.

ROLLING

they may be less in evidence. The only effective solution is to improve the standard of leaf.

A good standard of leaf is a *sine qua non* for rolling, which ceases to be a straight-forward process when the wrong type of material is handled. Most of the trouble experienced in rolling can be traced to a poor standard of plucking. Yet, more often than not, the blame is laid on the rollers, without first taking into consideration the natural contribution from leaf of different types—brownish teas from low jat, blackish teas from high jat, flaky teas from tough leaf, twisted teas from succulent leaf and fibrous teas from stalky leaf. So long as these facts are not recognized, rolling will continue to appear to be a highly complicated technique in tea manufacture. There is also a marked variation in the fermenting properties of leaf, which if allowed to go unobserved, may put the wrong interpretation on the outcome of a single change in manufacture.

Fermenting Properties—These vary from bush to bush, field to field and estate to estate. They do not appear to have a direct connection with jat. Since the primary object of rolling is to induce fermentation it is obvious that rolling methods must bear some relationship to the fermenting properties of the leaf. A poor fermenter may well benefit from more rolling than a rapid fermenter. The continuous methods of rolling, reference to which will be made later, were evolved with this object in view. Prolonged rolling of a rapid fermenter on the other hand may result in over-fermentation. Each estate should therefore study the characteristics its leaf possesses as a whole and not slavishly follow a system of rolling that gives good results in another factory. It is impracticable of course to manufacture leaf from each field entirely on its own merits or demerits, but the fact that leaf from different fields may have entirely different characteristics must be recognised.

Degree of Wither—It may be said that the degree of wither is the most important factor affecting the method of rolling and all other operations that follow. Yet it is taken too much for granted. It is true that a wide range is permissible in withering, but the most important considerations are evenness in wither, and the avoidance of extremes. As stated in Chapter I, the juice must be mobile but the leaf mass must not become 'water-logged' during the process of rolling.

According to experimental data, leaf having a moisture content from about 48% to 62% is rollable. That is to say, if the wither lies in the range of 38% to 52% outturn of made tea to withered leaf, leaf will twist in the rollers. In practice, it is not possible to get a perfectly even wither. Allowing for the variations that occur in both leaf and stalk, a 43% outturn appears to be the lightest wither for satisfactory rolling. If softer, leaf may be rollable, but the application of heavy pressure causes the rolled mass to become "water-logged" thus impeding both circulation and aeration. Juice containing useful oxidizable matter may actually run out of the roller.

If the leaf is withered too far, to the point where it is crisp, flaky tea will be obtained on rolling. The flakes are easily distinguishable from those produced from under-withered leaf. The former are brown, the latter black. Should pressure be hard the over-dried portions crumble into dust. Rolling of over-withered leaf also results in an undue development of heat, partly because of the lower moisture content, and partly because of the heavier pressures necessary for pressing out the juice from the leaf. In the cup, over withering shows itself by a thin rasping liquor and greenish infusion. Nothing can be done in rolling to correct these

TEA MANUFACTURE IN CEYLON

defects. Likewise, very little can be done to reduce the softness and coarseness of liquor from under-withered leaf. Carefull rolling perhaps, but they will still lack the fullness and richness of liquors of properly withered leaf.

What is a proper withered rolling? It can best be defined as one which enables leaf to be rolled under pressure without the loss of juice and is not so hard as to make the extraction of sap difficult. These conditions are fulfilled when the outturn lies within the range of 43% to 80%. It must be stressed again that figures alone are not a fully satisfactory criterion; the standard of evenness of the wither is just as important.

The choice of a lighter or hard wither is referred to in the chapter under "Withering." There is no evidence that light withers give more colour in the liquor than hard withers, or that the latter produce more quality. These two characteristics are governed by the amount of rolling and fermentation the leaf receives, and its intrinsic properties.

Rolling Charge—For economic reasons the amount of leaf charged into a roller must be as high as possible, but for successful rolling one of the essential conditions for which is brisk circulation of the leaf under pressure, charges must not be excessively high. Of late owing to increased crops coming in on estates there appears to be a tendency to raise the height of the jacket of a roller with a view to increasing its capacity. In many instances the normal charge has been almost doubled. In the case of some old rollers with shallow jackets such action is permissible but in others it will only result in unsatisfactory circulation and lead to thinner and less coloury liquors. To avoid the risk of overcharging a roller it is suggested that the height of the jacket should not exceed $\frac{3}{4}$ its diameter. This relationship holds good for all sizes of rollers. In the long run it will be false economy to over-charge rollers because, though apparently a smaller number of machines are used, the leaf will receive less rolling.

The capacity of a roller, apart from its size, is mainly governed by the design of the central portion. With most tables a simple true cone fixed on the door will ensure adequate circulation even under moderate pressure. Leaf should not be caked on top of the jacket and, when a solid mass is formed beneath the pressure cap, a roller can be considered over-charged. However, this is not an infallible test, because heavy pressure applied suddenly can cause caking of the upper layers. Battens on pressure caps interfere with the circulation of the leaf and may produce similar results. Lightly withered leaf is also at times a contributory cause. What constitutes an over-charge or under-charge is a difficult matter to decide. The optimum charges given in Table XIII may be found helpful.

Table XIII. *Optimum charges for standard batten pressure cap rollers.*

Roller	Withered leaf—lb.	Rolled leaf—lb.
47"	750	800
45"	550	600
44"	400	440
40"	350	380
36" (Deep jacket)	300	330
36" (Standard jacket)	250	270
35" (Octagonal)	300	330
34"	225	250
32" (Octagonal)	250	270
32" (Square jacket)	250	270
28" (Octagonal)	125	140

ROLLING

These figures are based on normal withers. If light or hard withers are taken, it is safe to add or deduct 10% respectively. This table should not be used indiscriminately, since the dhool outturn required is another factor. For example, if in the first rolls a high dhool outturn is not required, less harm will result if a rollers is over-charged. There is also the question of the particular roll to be considered. The same charge, for instance, in the 2nd and 4th rolls under identical pressure will not give the same dhool outturn. Smaller charges are always preferable for later rolls. The guiding principle should therefore be the degree of circulation obtained under the pressure required to give the necessary dhool outturn.

Roller Speed—This is closely linked with charge and circulation. To get leaf to circulate properly a roller must run at a reasonable speed. Excessive speeds are not only wasteful of power but they also tend to delay the progress of fermentation. The crank of a roller is the governing factor. If large, the speed should be low and *vice versa*. Most modern rollers are provided with relatively long cranks which assist the circulation of leaf and need not be run at more than 40 r.p.m. For all general purposes speeds of 35 to 40 r.p.m. should therefore be adequate. Lower speeds may improve the appearance of the made tea slightly, but the slower circulation may have to be counter-balanced by longer rolling.

Higher speeds are necessary only if rollers are over-charged or the cranks too small. Double action rollers which are as a rule provided with smaller cranks than single action rollers may therefore have to run at speeds higher than 35 to 40 r.p.m. A suitable speed for such rollers is about 45 r.p.m.

Degree of pressure—Application of pressure is essential for squeezing out the sap and forming dhool. In an epicyclic pressure roller it is applied laterally by the central fitting. In the batten-pressure cap technique it is applied from the top by lowering the pressure cap. It is perhaps not realized that the mass of leaf itself exerts a certain amount of pressure. Some idea of the pressure leaf is subject to in the ordinary course of rolling may be gleaned from the figures given in Table XIV, obtained from a 36" roller charged with 350 pounds of leaf.

Table XIV. *Roller pressures at table level.*

Conditions	Total pressure lb.	Pressure. Lb. per sq. inch (approximately)
1. Pressure cap not lowered	350	$\frac{1}{2}$
2. Light pressure	700	1
3. Medium pressure	1,000	$1\frac{1}{2}$
4. Heavy pressure	1,500	2

These figures include the weight of the pressure cap, which was 330 pounds.

The extent of pressure is controlled by means of the tension on the spring of the pressure cap and, if the spring on the roller is calibrated in this manner, it is a simple matter to find what pressure is applied on the leaf.

Since the weight of a pressure cap and tension of its spring vary from roller to roller, terms such as half, quarter and full pressure have no

TEA MANUFACTURE IN CEYLON

meaning. Further, it must be borne in mind that the same pressure on two different rollers need not necessarily have the same effect. If one has a poorer dhool-producing table, more pressure will have to be applied to get the same results as from the other. Dhool outturn and the appearance of the dhool are the best means for defining the pressure applied, but these too will mean next to nothing at all unless dhool outturn is defined in terms of mesh size, and the appearance of the dhool is judged by trade requirements. The desirable result varies with different types of leaf and is a matter of experience and judgement. It is indeed a dangerous practice to gauge the pressure on leaf from percentage dhool alone. A type of batten that cuts rather than twists will give a large percentage of dhool passing through large sized mesh with comparatively very little pressure. If the spring on the pressure cap of this particular roller is weak, it may be fully compressed without giving a very large pressure and in such a case, the full spring compression and the high dhool outturn may give a misleading impression of hard pressure.

Terms such as 'hard pressure' and 'light pressure' should not be used unless it is certain that they are justified.

Increase of pressure in a roller can of course be gauged by the tension of the spring, which should be calibrated in inches, and the extent of pressure applied noted by the compression in inches. This is a simple method of controlling pressure application during rolling. Ideally each roller spring should be calibrated in pounds per square inch at table level and checked annually.

The amount of pressure to be applied on leaf, or in other words, the type of rolling to be adopted, depends on the condition of the leaf and the type of tea required. The general rules are:—

1. Light pressure for soft withers and heavy pressure for hard withers.
2. Lighter rolling in the earlier rolls, and heavier rolling in the later rolls.
3. Heavy rolling for short rolls, and light rolling in association with long rolls.
4. Less number of rolls for heavy pressure, and a greater number of rolls for light pressure.

These are the main principles, but whatever pressure is applied a brisk circulation of the leaf must be maintained to get the best results.

Method of pressure Application—The first fundamental is that pressure must be applied to the leaf gradually. If the pressure cap is lowered suddenly, and too much pressure applied, the upper layers become caked and the leaf will continue to remain in this condition till the cap is raised. Under these conditions a part of the leaf remains unrolled and the temperature of the leaf rises. With free circulation the heat development is not so great. Rarely in practice will all the leaf circulate free under pressure. Rollers may be over-charged, balls formed in the process of rolling, or tables may be unsatisfactory. To counteract these pressure is released by raising the pressure cap at regular intervals. The variety of pressure periods in different factories is simply bewildering—5 minutes on 5 off, 7 on 3 off, 4 on 3 off, 8 on 2 off and

ROLLING

even 2½ on 2½ off. It is supposed that by these manoeuvres a proportion of the heat is dissipated. The significance of these operations is seldom realized, and an examination of the question is therefore necessary if methods of pressure application are to be rational. For too long they have been a teamaker's fancy.

It is indisputable that as leaf is rolled its temperature rises. The increase in temperature is mainly dependent on the charge and the amount of pressure. The greater the pressure applied the greater the amount of heat development—the phenomenon is purely one of conversion of mechanical energy to heat. It is reasonable to expect therefore that the longer pressure is applied the higher will be the temperature. Releasing pressure must, in the circumstances, check further heat production, and simultaneously greatly reduce the work being done on the leaf. In this way only is a rise in temperature checked. For the leaf to be appreciably cooled the roller will have to run a considerable time without applied pressure.

The function of rolling is performing useful work on the leaf. It is uneconomical to run a roller merely to churn the leaf, so that the longer leaf is rolled without pressure, the more power and time wasted. Release of pressure must accordingly be carried out judiciously and in relation to the total work done.

To illustrate what is meant, two familiar methods of pressure application may be compared—5 minutes on 5 off, and 8 minutes on 2 off in a 30 minutes roll. Actual rolling time is 15 minutes for the former and 24 minutes for the latter. If the pressure applied in the two cases is the same, the latter method will give more than 50% extra rolling. If the amount of work done on the leaf is to be the same, heavier rolling for the former or lighter rolling for the latter is necessary. The temperature will then be the same for both because the work performed is the same, but the peak load for a 5 minutes on 5 off system will be greater. This is a factor that must not be overlooked in a factory short of power. Heavy pressure for short periods imposes a greater strain on the power unit than lighter pressure for longer periods.

Although the total work performed on two lots of leaf may be the same, the teas may be entirely different. Leaf rolled for a longer period under lighter pressure tends to produce a tea with better appearance, but a lighter liquor than leaf subject to repeated applications of heavy pressure. One difficulty common to both methods is to know how long pressure should be released. Two or three minutes, at the most, should be ample, whether pressure is applied for 2 minutes or for 10 minutes. Rigidly adhering to an interval of 5 minutes between pressure application is not going to keep the leaf any cooler.

In the first rolls where usually less pressure is applied, raising of the pressure cap may not be necessary at all except perhaps in the middle of the roll in order to release any leaf jammed at the sides or at the top. The more frequent pressure release are actually needed in the later rolls not so much because of the higher temperatures, but because of the caking of the leaf, but for all that, it is a common feature in most factories to have the same system of pressure application for all rolls. While it is impossible to prescribe a system suitable for all factories, the principle should be longer periods of pressure for early rolls and shorter periods of pressure for later rolls.

Temperature—"Heat is the enemy of quality." This is one of the oldest tea making maxims and has much in common with "Money

TEA MANUFACTURE IN CEYLON

is the root of all evil." Both are utter nonsense. It is the love of money that is evil, and *excessive* heat that is inimical to quality in tea making. Warmth is the father and mother of quality for without it, tea leaf cannot ferment and the product is as raw and green as the fresh leaf. The method of rolling should be such that sufficient heat is generated in the rollers to enable the dhool to ferment satisfactorily at room temperature. If rolling is inefficiently carried out or the dhool over cooled during roll-breaking the rate of fermentation will be very considerably reduced. To get fermentation to start as soon as possible in the rollers and not slow down the process subsequently is therefore the essential need. From the knowledge of fermentation acquired so far it would appear that so long as the temperature of the leaf on the fermenting tables does not fall below 70° F. fermentation proceeds at a normal rate. But the important thing to note is that for the dhool to contain this amount of warmth at the time it is taken to the fermenting tables the leaf would have to attain a much higher temperature in the rollers. Since under such conditions a considerable proportion of the fermentation takes place under the warmer conditions in the rollers the necessity to continue fermenting the dhool at the higher temperatures attained in rolling does not arise. In fact it may do more harm than good. Appendices C and D convey an idea of the heat generated in rolling and the cooling effect during roll-breaking.

Exaggerated fear of heat in rolling has, in the past, resulted in experiments with brine cooled roller jackets; the fermentation was impeded by the cooling and nothing of any practical value was achieved. High elevation factories are sometimes gravely handicapped by excessively cold rolling rooms and find difficulty in eliminating a raw, green character from their liquors, in spite of extended periods of fermentation. If the fermentation process is not well advanced within the first two or three hours of the commencement of rolling no amount of time on the fermenting tables at a low temperature will eliminate the raw, green character which results from such unsuitable conditions. Small rollers are sometimes excessively cooled by a relatively high ratio of metal in the jacket and table, to the bulk of the leaf. The small 30 pounds charge experimental rollers at St. Coombs show comparatively small rises in temperature during the heaviest rolling and in the cold weather it is extremely difficult to eliminate a greenish character in the teas produced from them.

The rate of fermentation does not go on rising indefinitely with temperature. Above 90°F it falls and undesirable changes due to heat, as distinct from fermentation, begin to take place. Excessive heat must therefore be avoided and the most effective practical way of doing so is to ensure a good circulation of leaf which in turn pumps cool air through the roller. Circulation may be assisted by raising the pressure cap at intervals. In general, the aim should be to keep the leaf in the rollers at a temperature between 80 and 90°F. This may be a counsel of perfection, but nevertheless may still be regarded as an objective. The factors which assist in preventing excessive heat development during rolling are enumerated below:—

- (1) good circulation of leaf,
- (2) raising the pressure cap at intervals to assist circulation.
- (3) reducing the roller charge especially for later rolls where applied pressure is high,
- (4) the use of mist-chambers and fans for a sweep of cool, humid air in the rolling room (humidification alone, or recirculation of air within the rolling room is useless),

ROLLING

- (5) reducing the rolling period.
 - (6) taking a lighter wither.
- and (7) in extreme cases, where the factory equipment is inadequate, and is the basic cause of excessively hot rolling, rolling at night, or in the early hours of the morning.

Temperature must be actually measured with thermometers because the senses can be most misleading. For instance, the leaf discharged from a roller at 70°F in the early hours of a cool morning can feel just as hot to the touch as say leaf at 90°F in a room temperature of 80°F. "Steam" emanating from a roller may be equally misleading because water will condense to vapour in a cold humid room very readily, similar to breathing out "steam" on a cold morning. Under normal working conditions the temperature rise in rollers is seldom less than 10°F above that of the rolling room and, on the average, rolling under pressure with good circulation will bring about a rise of 15 to 20°F. It is by no means uncommon to find a temperature rise of 30°F. but this must be regarded as excessive. Few tea factories will be situated in areas where the wet bulb temperature exceeds 80°F. If the factory has an efficient, and properly designed mist-chamber, rolling temperatures may still rise as high as 100° under heavy pressure. When the maximum wet bulb temperature is 80°F the early morning temperature will not exceed 70°F, and may be as low as 65°F. There is still, therefore, in extreme cases, opportunity for keeping the maximum rolling temperature under 30°F.

The highest temperature rises are liable to occur in the later stages of rolling when the applied pressure is highest. The greatest care must therefore be exercised in combining roller charges, it being preferable, on the whole, to organize rolling so that the bulk is passed on from single roller to single roller of suitable size, rather than to pass from two rollers to one roller, and risk over-charging with consequent liability to over-heating. It must be realized that opened top (E.P.) rollers generate just as much heat as pressure cap rollers and, although the circulation in E.P. rolling should dissipate heat more quickly than pressure cap rolling, the problems of over-heating are not automatically solved by E.P. rolling.

Size of Dhool and Amount Extracted—Proper dhool should be produced by a twisting action. If produced by a cutting action alone, the appearance is very choppy and flaky, and only the cells along the cuts will be ruptured. Everything depends on the efficiency of the wringing action in the roller, which in turn depends on the type of battens and method of rolling. The nature of the leaf also controls the appearance of the dhool, different effects being produced according to the pluck, which does not always break up in the same way.

However good the standard of the plucking may be, or however good the machinery to roll it, the most important factor is the wither. Under-withered or over-withered leaf flakes in the roller and the admixture of any such a leaf in a roller charge results in a tea consisting of particles of different size and "make". If an even dhool is to be obtained withers must be good.

The points of major importance are first, size of dhool and secondly appearance of the dhool. The size of a dhool is determined by the size of the roll-breaker mesh, and the appearance of the dhool is determined by the efficiency of the rolling operation, especially the efficiency of the batten arrangements which will be dealt with later in this chapter.

Roll-breaker mesh must be selected according to the requirements in the matter of the size or make of the various grades turned out by the

TEA MANUFACTURE IN CEYLON

particular factory. Generally speaking, if a small B.O.P. and high percentage of fannings is required, as is normally the case in up-country factories, a small mesh will be used. If bold grades are wanted, such as large low-country B.O.P.s and pekoes the mesh must be larger. The use of the following meshes will probably meet average requirements :—

Low-country	No. 4 mesh
Mid-country	No. 5 mesh
Up-country	No. 6 mesh

The subject of roll-breaking will be dealt with in detail in Chapter 7.

Once major decisions on the subject of roller battens and roll-breaker mesh have been taken, daily faults in withering and rolling may be detected by examining the dhools. Gross over or under-withering will be revealed by an excess of flake. This may arise from a proportion of an uneven wither perhaps from a few tats only, which is not so easily detected in the mass of withered leaf.

The severity of rolling may be judged to some extent by the percentage of dhool extracted after each roll, but an examination of the appearance of the dhool can serve a useful purpose. If, for instance, although the roller battens are standardized and are normally satisfactory, too much pressure is applied in the first ten minutes of say a first roll producing say 15% of dhool through the particular mesh which has been selected, the dhool will appear ragged and uneven compared with a 15% dhool which has been produced by even pressure throughout the whole rolling period. In other words, the percentage of dhool is by no means an infallible guide to rolling pressure and it must be clearly realized that dhool percentage figures, in the absence of careful organization and standardization in the rolling room, can be dangerously misleading. In any case a dhool percentage means nothing whatsoever unless specified in terms of the mesh through which it has been extracted. All that can be said about this subject is that dhool figures should only be used as a check for the pressure employed in rolling and for the amount of leaf charged into a roller. "To take small first dhool percentages" or "to take large dhool percentages" are vague statements. They can mean anything. It is therefore better not to attach too much importance to dhool outturn figures. The more important thing is to see how the leaf has been rolled.

Just as discrimination is needed in distinguishing a good wither, correct judgment is necessary for rolling. One of the essentials for good rolling is not to break up the leaf too quickly in the first rolls. In the low-country it may be advisable to have the flush kept almost entire for even the second roll. On the other hand, in up-country factories, where smaller teas are required, rapid dhool production should start as soon as the leaf is well twisted. The separation of tip, tightness of twist, exposure of midribs and stalk will give a far better indication of the manner of rolling than any dhool outturn figure can hope to give. The percentage of big bulk is, however, a more reliable guide to the effect of rolling. Here again mesh size is important and taking the three standard sizes previously mentioned, leaf cannot be considered properly rolled if the big bulk outturn is more than 5% from a No. 4, 10% from a No. 5, or 15% from a No. 6 mesh. For low-country manufacture these figures do not apply because appearance of the leaf is a more important consideration than the quality of a liquor. Higher big bulk outturns are preferable but should not exceed 25%, otherwise the big bulk will tend to be 'open'. A tightly twisted big bulk is the main criterion of successful rolling. If

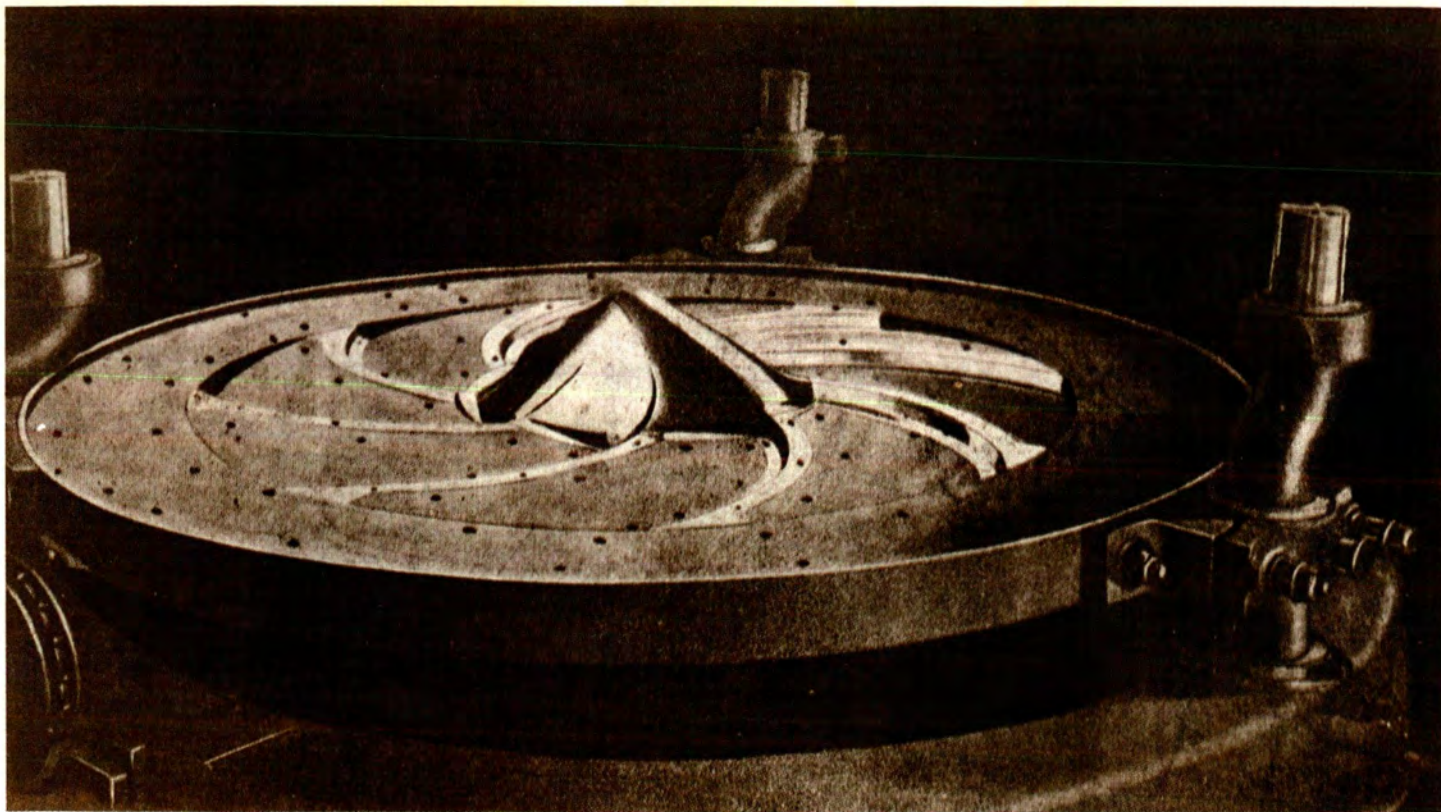

PLATE II—Roller table with M. & S. batters and 'fadeaway' cone

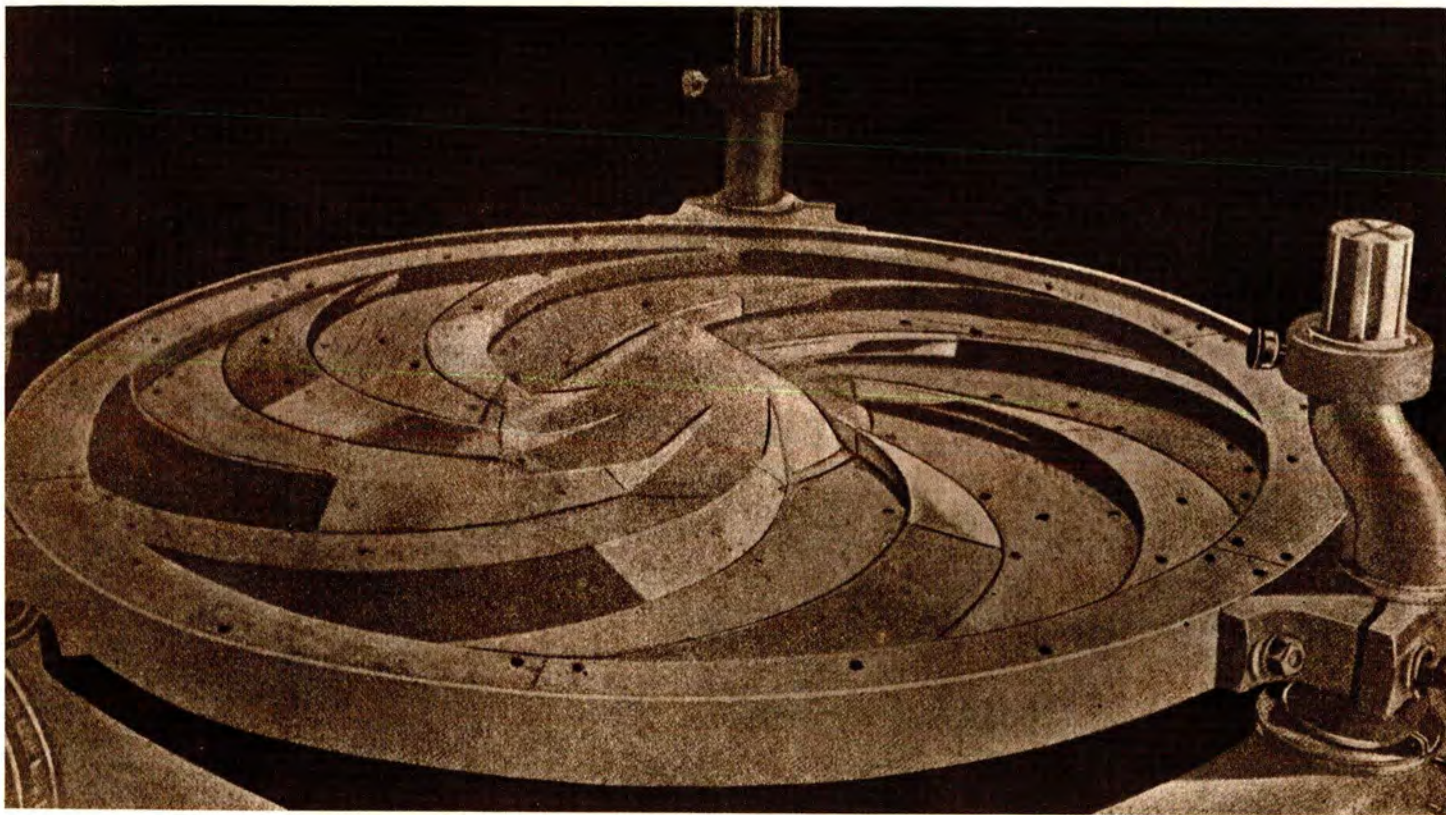

PLATE III—Roller table with Crescent batters and 'fadeaway' cone

ROLLING

its outturn low as well, the percentage of broken mixed will be kept down. A true big-bulk should consist only of twisted stalk with the minimum amount of leaf attached to it. A leafy big bulk is an indication of insufficient rolling.

With the outturn and character of the big bulk and the appearance of the first roll bulk to act as guides, it is not difficult to know where one stands in the intermediate stages. Dhool outturns can be varied as desired without the character of the tea being seriously affected. Dhool outturn may increase or decrease as rolling proceeds, dependent on the sizes of rollers available, and their dhool producing capacities. A wide latitude is permissible but not without some discretion.

Charging Interval—The duration and number of rolls is, in the main, governed by the charging interval. For example, if a charging interval is only 40 minutes and the same roller or rollers used for the same roll, the maximum practicable period of rolling is 30 minutes because at least 10 minutes must be allowed for discharging and recharging. The number of rolls is similarly affected. With a longer charging interval two rolls may be carried out on the same machine. In practice, it is not quite so simple, for a rolling programme runs to a time schedule, roll-breakers have to be available at certain times, rollers should not be discharged simultaneously and driers must be kept fully loaded. In addition there is the question of roller charges to be considered. The charging interval has to be related to the initial charge required to keep a drier continuously fed with leaf. Another point to be considered is the economic use of the machinery. Rollers and roll-breakers must not be kept idle too long.

Until comparatively recently, very little attention was paid to this aspect of the rolling operation. Rollers were charged whenever they happened to be available; driers running empty or overloaded were overlooked; the period of fermentation did not appear to matter much. What mattered most was clearing the leaf off the tats.

Today, the advantages resulting from a fixed charging interval have come to be recognized and more and more factories are putting manufacture on an organized footing. Rolling programmes are now an integral part of tea manufacture. They are discussed fully in the Chapter under 'Factory Organization.' The real value of a fixed charging interval in rolling lies in the consistency of results. Control is simplified and supervision made easier. Period of fermentation are fixed since initial charges are constant, and all the other operations fall in line systematically. Variable charging intervals are out of place in any factory unless it is very badly equipped with machinery and withering facilities.

A standard charging interval in most factories is 50 minutes on a 30 minutes roll programme. This interval has been found to be very convenient and economical. The allowance of time for recharging of rollers and for roll-breaking is ample and the programme runs smoothly. Machinery requirements are now, as a rule, based on a 50 minute charging interval.

Longer charging intervals are uneconomical except when a roller is used for two successive rolls. In the low-country longer intervals may be preferable because the overall period of fermentation is increased, which enables more colour in the liquor to be developed. At higher elevations they may not suit. Quality in a high-grown tea is more important than colour and one method of preserving the former is by having the shortest charging interval possible.

TEA MANUFACTURE IN CEYLON

Type of Roller Battens.—It is doubtful whether a batten can be designed to suit all types of leaf and all methods of rolling. Some battens are, however, of a good general purpose design. The M & S batten is an example and its efficiency is improved by the conical centre adapted to it by the Tea Research Institute of Ceylon. Plate II illustrates the general arrangement, in which it will be noted that the battens are continued on to the surface of the cone and merge into it. This 'fade-away' cone has now been standardized for all sizes of rollers and may be obtained from the Colombo Commercial Company. It is most important that drawing No. 4429C should be quoted. Shallow cones should on no account be used with this arrangement. If steeper cones are required to increase dhool putturn without resort to excessive pressure, they should have smaller bases, the angles at which should be 45° . Appendix E gives the dimensions of this type of cone for all rollers in general use.

Another standardized type of batten now common in Ceylon tea factories is the Crescent, a modified form of the Lamont Mitchie. Being milder in action than the M & S it may prove more suitable for those low country estates where a very high standard of leaf appearance is required. Crescent battens have for a long time been associated with Rettie cones, which have been found to be very satisfactory in some estates but not in others. The manufacturers, Messrs. Walker Sons & Company, have therefore agreed to incorporate with the Crescent batten the cone developed by the Tea Research Institute as shown in Plate III. Under moderate pressure a 35° cone with Crescent battens does not produce large amounts of dhool, and is suitable for early rolls only. It may be used with heavy pressure to increase dhool production, but a simpler expedient is to have a Keegel conc or perhaps a Rettie cone when harder rolling is required. A fade-away arrangement does not appear to make any material difference. By a suitable combination of these two types of battens, it is possible to meet any requirement. There need be no longer, for some time at least, any difficulty in the choice of battens.

Before the advent of the cone a step arrangement, octagonal in shape, was commonly fitted in the centre of the table. It did not prove a success for when fitted above table level it cut up the leaf and when fixed below the level of the table it became a poor dhool producer. Figures 12 and 13 show how this effect was produced.



FIG. 12. Octagonally shaped device, which, when fitted above table level, cuts up the leaf



FIG. 13. The same octagonal arrangement as shown in Fig 12, but fitted below table level

Some confusion still exists regarding the function of battens on pressure caps. These were introduced in the early days to compensate for the poor dhool producing tables. Two typical types are shown in Figures 14 and 15. These tend to impede circulation of the leaf and are

ROLLING

no longer necessary owing to the effect exercised by central devices, fitted on roller doors.

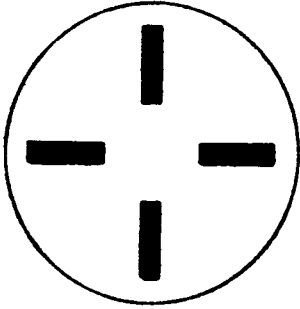

FIG. 14. Under-side of a pressure cap with four small battens

The restriction of circulation by battens on pressure caps prompted Messrs. Davidson & Company to introduce concave shaped pressure caps to their rollers, (Fig. 16), but these possess one serious disadvantage, which is not offset by improved circulation. Because of the reduced effective area of pressure, dhool outturn is considerably reduced.

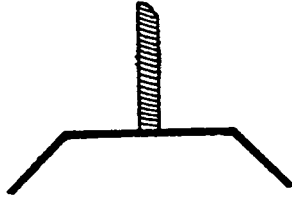

FIG. 16 Concave shaped pressure cap in a Davidson roller

The most essential need is, however, for a properly designed fitting in the centre of the roller table. A centrally fitted true cone, described earlier in this chapter, as shown in Figure 17, induces a brisk circulation, and a plain pressure cap with a smooth unencumbered surface causes comparatively little restriction of circulation.

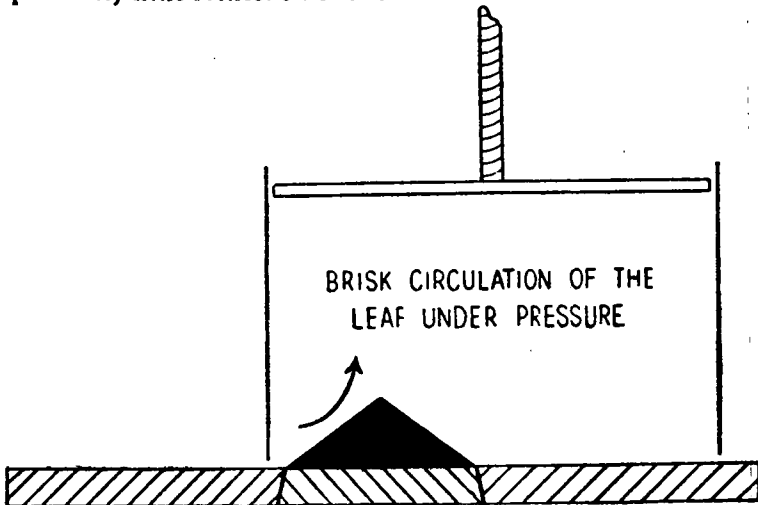

FIG. 17. Arrangement of a plain pressure cap and a plain cone fitted at the centre of the roller table

TEA MANUFACTURE IN CEYLON

A fitting of this type will be found suitable for all normal purposes with most batten types, and can be safely used, provided the necessary precautions are taken as regards clearance, angle at the base, and projecting edges. It should be cast in brass to reduce wear and tear. For a similar reason metal tables and battens are preferable to wood, but in case wooden battens have to be used, they should always be constructed with sound timber and protected with brass inserts.

Claims are often made that wooden tables produce a slightly better twist than metal tables. There is no evidence to support this statement. Even if it were true, there is a strong case for the employment of metal roller tables as they help to prevent excessive development of heat.

Type of Tea Required—Various types of tea are in demand, the two most important of which are those with a good appearance, and those with quality liquors. These in turn may possess the other characteristics such as colour, strength and pungency in varying degrees. The production of flavoury teas is of course in a special class by itself. Whatever methods are adopted in developing these characteristics it may be as well to remember that the requisite properties must be in the leaf to start with.

Every estate has its particular peculiarities and requirements. To give details of a rolling programme best suited for the development of this or that characteristic would be absurd. The most that can be done is to suggest a course of action that may be adopted for the preservation and development of appearance and quality.

Tip—Tip is the product of buds and small leaves carrying long, minute plant hairs, which are evidently provided by nature for protection of the delicate shoots. During periods of slow growth in wet weather there tends to be more hairs on tip of the flush with the result that more tippy teas result from their manufacture. At certain times of the year however these hairs may be present in such a very small amount that the tip will hardly be noticeable in the made tea. To recover the maximum amount of tip, leaf should receive gentle treatment. Application of pressure must be adjusted according to the length of tip required. Hard pressure results in the tip getting broken up and if prolonged will eventually cause its loss. The total amount of tip must be considered in relation to the quantity dhool for a small dhool outturn may give the misleading impression that an appreciable amount of tip has been preserved. After rolling has proceeded for some time, it is pointless continuing with light pressure with the sole object of getting whole tips. The value of a tip lies not only in its length, but in its colour. If the latter is to be developed more juice must be expressed from the leaf, because it is the deposition of the juice on the hairs that gives a tip its characteristic golden colour. Judicious application of pressure will bring about the desired effect. If pressure is lacking, the tips tend to be pale in colour ("silver" as opposed to "golden" tip).

The correct size of roll-breaker mesh must also be employed. For all general requirements a No. 4 mesh will answer. The danger in using a larger mesh is that unrolled leaf will pass through. A smaller mesh prevents some of the tip from being removed, resulting in it being re-rolled, with the possible consequence of the hairs being abraded. The whole question of preservation of tips really boils down to the preservation of the hairs on the bud and expression of juice from the leaf. What must be avoided therefore are:—

ROLLING

- (1) hard withers (very soft withers give poor colour),
 - (2) fast roller speeds,
 - (3) excessive pressure,
 - (4) prolonged rolling
 - (5) poor circulation,
- and (6) rubbing of the leaf over roll-breaker mesh.

Appearance—The requirements for a good standard of appearance are many; they are a good twist, blackness, even size, absence of reds, and presence of tip. To produce a tea of such ideal appearance, a very high standard of leaf is required. In any case, there are two uncontrollable factors—jat and climatic conditions—that limit the extent to which these requirements may be met. Considering the general appearance of a tea as a whole, without specific reference to well twisted, black low-country teas, or stalky teas from coarse plucking, one essential is that a tea should not be flaky. One of the causes of flakiness is a poor wither. Another is old, tough banji. The most efficient rollers or the most careful rolling technique cannot twist these types of leaf. A good wither and soft leaf are therefore essential to ensure a high standard of appearance in the made tea.

If a good appearance is the only feature required of a tea, prolonged period of light rolling will give the best results. This means that leaf should be rolled as many times as economical working will allow. It may be six times or even more, depending on the duration of the rolls. Breaking up of the leaf should only commence after the leaf has been tightly twisted. To produce this preliminary effect may take as long as one hour. To rely only on the weight of leaf and circulation to bring it to this condition is not safe. Extraneous pressure has to be applied. Pressure should then be gradually increased and the process terminated when the big bulk is reduced to about 20% of the initial charge. A method of rolling such as that described, would only be appropriate to low-country estates and those places in the mid-country where conditions resemble those in the low-country. In other districts liquoring properties are of greater importance, and if these are to be developed to the maximum possible extent it is obvious that leaf must be rolled harder. Leaf cannot, however, be rolled hard without a sacrifice in appearance. The correct balancing of liquor and appearance to satisfy market demands is one of the hardest things in tea manufacture.

For a good, all round tea, time should not be wasted by working up the leaf into a mass of well twisted whole shoots. More pressure should be applied in the initial stages, but graded in such a way that the leaf does not get broken up too quickly. Small roll-breaker mesh No. 5 or No. 6, should be used; hard rolling adopted from the second roll and continued in subsequent rolls till the big bulk outturn is reduced to 10%. The pressure in the early rolls cuts down the total rolling period and it may not be found necessary roll more than four times. If the big bulk cannot be reduced to the figure mentioned, a fifth roll should be carried out. Some factories, however, do not possess sufficient machinery for additional rolling in which case the following procedure may be adopted: The bulk at the end of the fourth roll is re-rolled with the bulk from the third roll of the next batch. The big bulk obtained from this roll is similarly treated and re-rolling continued till the end of the day. The big bulk is then reduced to a very small amount. This method will fail to give the desired results if a large roller is not available for the last roll because the bulk tends to increase with each successive batch of leaf.

TEA MANUFACTURE IN CEYLON

Another point to watch is the increase in the amount of red stalk due to the extra rolling of the bulk. The method suggested should cease when reds are inclined to be too prominent, and be restarted with a fresh batch of leaf. The standard of appearance will in this way be maintained. If more colour and strength are required in the liquors, appearance will have to be sacrificed still further.

High grown Quality—The preservation of this characteristic does not entail any elaborate system of rolling. The process is entirely straightforward, the inherent quality being brought out in the liquors by short rolling periods, and hard rolling. Dhool production should be as rapid as possible without resort to types of batten which cut rather than twist the leaf, although this will result in a destruction of tip. A show of tip in an up-country quality tea does comparatively little to enhance its value. The general appearance of the tea does however matter, but if the wither is satisfactory, relatively hard rolling can be employed from the time the leaf is well twisted, without seriously impairing the appearance.

When flavour is much in evidence, other characteristics have little value in the eyes of the trade. The greatest enemy of flavour is excessively high temperatures. If loss of flavour is to be avoided the temperature of the leaf should be carefully controlled, and this is when a humidifying appliance shows its worth. Curtailment of rolling for the preservation of flavour then becomes unnecessary.

Humidifying Appliances—An efficient humidifying device does two things. It reduces the temperature of the air and increases its humidity. It cannot, however, reduce the temperature below the wet bulb temperature of the air. That is to say, if the outside temperature is 80°F (dry), 65°F (wet) the lowest temperature that can be attained is 65°F; if 67°F (dry) and 65°F (wet) the conditioned air will still be 65°F. It is necessary therefore to emphasize that no matter how efficient the design of a system may be, the wet bulb temperature is the lowest limit. An efficient system must also introduce fresh air continuously to sweep away heat given out by the operatives and machines, and it should also lower the temperature of the rolling room to within 2 to 3°F of the wet bulb temperature. Another point that needs clarification is the belief that the use of a modern humidifying plant will ensure constant temperatures in a rolling room. This cannot be in view of the marked variation in the wet bulb temperature of the outside air. Despite these variable results a humidifier will continue to serve a useful purpose in tea factories, but as in the case of an artificial withering system it can be abused at times.

Most tea factories are so designed that rolling and fermentation are carried out in the same room. Such an arrangement should give satisfactory results so long as the temperature does not exceed 75°F. If this temperature could be lowered by the use of a humidifier so much the better for quality. A temperature of about 60°F can be regarded as a safety limit for general requirements. In some up-country factories at certain times of the year lower temperatures are experienced, but these conditions, though not favourable to fermentation, are conducive to the development of flavour, which is usually prominent during such periods. When flavour is strongly marked all other characteristics which are brought about by fermentation become less important.

The increased humidity resulting from the use of a humidifying plant reduces the evaporation of moisture from the leaf and thus maintains the temperature of the leaf on the fermenting racks. Free evaporation of water causes cooling and if too rapid may result in both drying

ROLLING

of the leaf and retardation of the rate of fermentation. A humidifying appliance must accordingly be used with discrimination and the following points have to be considered:—

- (1) outside air temperature, its relative humidity and its wet bulb temperature,
 - (2) the resulting temperature from humidification and how the new conditions compare with those of the outside air,
 - (3) the wither; soft withered leaf does not require such cool conditions as does hard withered leaf,
 - (4) fermenting properties of the leaf; poor fermenters may benefit from relatively high temperatures,
 - (5) presence of absence of quality and flavour,
- and (6) whether fermenting of dhool is carried out in the rolling room or in a separate room.

Whether mist chambers are used, or simpler schemes such as wet curtains, they will all fail in their object if ventilation is unsatisfactory. The continuous heat generated in a rolling room must be dissipated, and this requires a free flow of fresh air to carry the heat away. Ventilation must not be over-done; a gentle current of air is all that is necessary. Excessive draughts should be avoided, otherwise drying of the leaf is accentuated.

The moisture loss from the leaf varies considerably from factory to factory. A loss in weight of from 3% to 10% is not unusual, and is chiefly dependent upon the wither and upon rolling room conditions. Even under very humid conditions, evaporation of moisture from the leaf cannot be prevented. It is perhaps not realized that the greater proportion of the loss occurs in the rollers and not on the fermenting racks. At the same time, it is most essential to prevent loss of moisture *after* the leaf has been taken out from the roller.

In the simplest possible terms the requirements in the rolling room are for a flow of cool, humid air sufficient in amount to carry away the heat generated by rollers, labourers, electric motors, lights, etc. The humidity need not be 100% since a small amount of evaporation in the rollers does little harm; indeed it assists cooling.

In the fermenting room, on the other hand, a very high humidity is required and the flow of air should only be sufficient to supply the oxygen requirements of the fermenting leaf and to prevent stagnation and accumulation of carbon dioxide. On no account should the flow of air be so rapid as to cool or dry the fermenting leaf.

In a common rolling/fermenting room which is served by a humidifying appliance the precaution that should be taken therefore is to see that the fermenting racks are not situated in an area of rapid air movement. In any case excessive draughts should be avoided whether rolling and fermentation are carried out in the same room or in different rooms.

If these precautions are taken and the dhool transferred to the fermenting racks as quickly as possible the cooling effect of the conditioned air is minimized and warmer conditions are available for fermenting. There will then be no need for external aids to keep the dhool at a

TEA MANUFACTURE IN CEYLON

temperature higher than that of the rolling room. Accordingly, the best that can be done is to restrict the air movement over and around the fermenting racks and transfer the dhool to them as quickly as possible. This helps to keep the leaf at a temperature higher than that of the rolling room for a considerable time after it has been sifted. In this way the cooling effect of the conditioned air is minimized and warmer conditions are available for fermenting of the dhool.

CHAPTER 6

CONTINUOUS ROLLING

A method which is now being employed in some up-country factories with very good results is one in which fresh charges of leaf are continuously introduced into the rolled leaf. The replacement of dhool by withered leaf continues till the end of the day. After the last lot of withered leaf has been fed, rolling proceeds on normal lines until the big bulk is reduced to about 3% of the initial charge constituting a very low percentage on the day's outturn of rolled leaf.

This method should not be confused with another procedure of old standing in which the big bulk is continuously rolled, reference to which was made on page 63. The underlying idea in adopting continuous rolling is to improve colour and strength of a liquor, an objective sometimes difficult to attain by orthodox methods without the use of extra machinery.

Continuous rolling is no longer a 'hit or miss' business and if carefully planned would give the desired results. The requirements to make it a success are:—

- (1) A good standard of plucking.
 - (2) A good wither.
 - (3) Rollers capable of producing a large amount of dhool.
 - (4) Rollers not to be initially charged up to normal capacity.
 - (5) A total initial charge which should as far as possible not be greater than what the drier or driers can handle in 2 hours.
 - (6) Subsequent charges to be roughly equivalent to one third of the initial charge, and the dhool produced also near about this figure.
 - (7) The dhools be fired in the order in which they are produced, keeping the drier or driers continuously fed.
- and (8) The period of fermentation given for the first dhool to be so adjusted that later dhools receive the correct fermentation, depending on the type of tea required.

If the leaf is inadequate for at least five batches, little will be gained by continuous rolling because it is tantamount to rolling five times except that a more even infusion may result from the mixing of juices from freshly rolled leaf and coarser bulk. The warmth of the bulk that is returned to the roller also helps to accelerate the fermentation of the fresh charge.

Since this form of rolling is a combination of hard rolling and continuous replacement with withered leaf a higher degree of rupturing of the cells occurs. This action is further improved by the fact that rolling is started with a roller only partly full. Better circulation of the leaf under pressure is thereby obtained, the outcome of which is a tea with improved strength and colour. By a suitable adjustment of the period of fermentation a balance can be struck between quality and colour.

Owing to the warmer average conditions of fermentation the period of fermentation has to be shortened as the day progresses. The rate of

TEA MANUFACTURE IN CEYLON

charging the rollers in relation to the capacity of the driers is therefore not so straightforward as in orthodox rolling. It has to be carefully calculated if over-fermentation is to be avoided. If colour is the only consideration, the period of fermentation need not be reduced for the later batches.

The keystone of the whole process is the outturn of dhool. It should be as high as possible and not very much less than the drier can handle for the interval between two successive rolls. It is not necessary to replace the dhool taken out with the same amount of withered leaf. In any case it is not practicable, but it would be advisable to have a constant charge since dhool outturn will be found easier to regulate.

The time firing should start should be based chiefly on dhool outturn and not on the period of fermentation that is considered to be the best for the first dhool. So long as the greater proportion of the day's leaf does not get more than $2\frac{1}{2}$ hours fermentation, it will not matter what fermentation is given to the first dhool. It may be necessary in some cases to reduce the fermentation of the later dhools to 2 hours or even less, and experience will show the lowest limit.

- (a) an initial charge required to keep the drier full for 100 minutes,
 - (b) subsequent charges to be one third (a),
 - (c) dhool outturn to be aimed at to be about equal to (b). In practice it will not be possible to obtain such a large dhool outturn in the early rolls, but if about 20% is taken out in the first rolls, and 25% in the second, no difficulty should be experienced in getting the required outturn after that,
 - (d) 30 minute rolls.
 - (e) 40 minutes intervals thus giving 10 minutes for roll-breaking and recharging,
- and (f) a period of fermentation not exceeding 3 hours for the first dhool (this may have to be adjusted in the light of results obtained).

The following example of continuous rolling programme will perhaps make this seemingly intricate process clearer :—

Programme—Continuous Rolling—For $3 \times 36''$ rollers (numbered 1, 2 and 3); 1 roll-breaker and 1 drier—intake about 360 lb. fermented leaf per hour (or 6 lb. per minute).

Initial charge	..	600 lb. withered leaf (8 rollers)
Subsequent charges	..	210 lb. withered leaf („)
Charging interval	...	40 minutes
Rolling period	...	30 „
Roll-breaking period	..	10 „
Period of fermentation for 1st batch		2 hours 45 minutes (Drier to be kept continuously fed thereafter).

Percentage dhool outturn to be aimed at .. 30 to 35.

Assuming that rolling starts at 7 a.m. (time pressure is applied to the leaf) a typical programme will be somewhat as follows :—

CONTINUOUS ROLLING

(a) *Rolling time table.*

BATCH	CHARGE	ROLLER No. 1	ROLLER No. 2	ROLLER No. 3
1	600 lb.	7.00-7.30	7.10-7.40	7.20-7.50
2	210 lb.	7.40-8.10	7.50-8.20	8.00-8.30
3	do	8.20-8.50	8.30-9.00	8.40-9.10
4	do	9.00-9.30	9.10-9.40	9.20-9.50

etc.

If the amount of leaf left over for the last batch is very much less than 210 lb. only one or two rollers may be used according to circumstances, and normal orthodox rolling carried out until the bulk is reduced to a satisfactory amount.

(b) *Roll-breaking time table.*

BATCH	ROLLER No. 1	ROLLER No. 2	ROLLER No. 3
1	7.30-7.40	7.40-7.50	7.50-8.00
2	8.10-8.20	8.20-8.30	8.30-8.40
3	8.50-9.00	9.00-9.10	9.10-9.20
4	9.30-9.40	9.40-9.50	9.50-10.00

etc.

(c) *Changing time table.*

BATCH	ROLLER No. 1	ROLLER No. 2	ROLLER No. 3
1	6.50	7.00	7.10
2	7.30	7.40	7.50
3	8.10	8.20	8.30
4	8.50	8.00	9.10

etc.

As soon as roller is discharged no time must be lost in recharging it with withered leaf, followed by the bulk from the previous batch. For these two operations only 10 minutes have been allowed.

(d) *Dhool outturn and roller charge (all 3 rollers).*

BATCH	CHARGE	DHOOL PRODUCED	BULK	LEAF ADDED
	LB.	LB.	LB.	LB.
1	600	120	480	210
2	690	180	510	210
3	720	240	480	210
4	690	210	480	210
5	690	270	420	210
6	630	240	390	210
7	600 etc.			

In this particular example the leaf added each time is a fixed amount of 210 lb. although the dhool produced varies from 120 to 270 lb. The important point to note, however, is that at no time is the total charge more than what the three 36" rollers could comfortably accommodate. This is because the rollers were initially only partly full, a most essential requisite in continuous rolling.

(e) *Firing times and periods of fermentation.*

Assuming first batch goes into the drier 2 hours 45 minutes after the commencement of rolling.

TEA MANUFACTURE IN CEYLON

BATCH	TIME ROLLING COMMENCED (PRESSURE APPLIED)	DHOOL OBTAINED LB.	TIME IN THE DRIER (AT 6 LB. PER MIN.)	PERIOD OF FERMENTATION
1	7.00	120	9.45-10.05	2.45
2	7.40	180	10.05-10.35	2.25
3	8.20	240	10.35-11.15	2.15
4	9.00	210	11.15-11.50	2.15
5	9.40	270	11.50-12.35	2.10
6	10.20	240	12.35- 1.15	2.15

Period of fermentation is entirely governed, as will be seen, by the weight of dhool in each batch.

(f) *Weights of charges according to above figures (per roller).*

BATCH	ROLLED LEAF	WITHERED LEAF	TOTAL
1	—	200	200
2	160	70	230
3	170	70	240
4	160	70	230
5	160	70	230
6	140	70	210

The system allows plenty of latitude and with a little experience will be found easier to manage than conventional rolling. It is unworkable, however, with E.P. machinery since pressures have to be frequently varied according to the amount of leaf in the roller. The method is not suitable for the production of tip or a high percentage of orange pekoe and cannot therefore be recommended for low country estates. It is also unsuitable during the good quality months in up-country areas, especially when flavour is present in the leaf.

Continuous rolling does definitely improve some teas and its adoption is justified only in the following circumstances:—

- (1) if the jat on an estate is a poor fermenter,
- (2) if rolling equipment is insufficient to carry out 5×30 minute rolls,
- (3) if the leaf harvested daily comes from fields possessing different fermenting properties.
- (4) if difficulty is experienced in reducing the big bulk outturn,
- and (5) if the outturn of broken grades is to be increased.

CHAPTER 7

ROLL-BREAKING

Roll-breaking is beyond doubt the crudest of all operations carried out in tea manufacture. Few serious attempts have been made to standardize the process and at the present moment the amount of dhool sifted out depends far too much upon the rate at which the machines are fed. Unfortunately the roll-breakers in any one factory may vary in type and efficiency. The least that can be done is to organize manufacture so that the bulk from any particular roll is always sifted on the same machine. Different machines may vary in:

- (a) the mesh with which they are fitted,
- (b) the speed of vibration,
- (c) the amplitude of the vibration (determined by the crank throw)
- (d) basic design, some being rotary, some reciprocating, some are fixed at the end and move up and down at the other, some move up and down at both ends and so on,
- (e) the slope of the tray.

Some roll-breakers are fitted with ball-breakers and others are not, but very seldom are they fitted with any type of automatic feeding device which is really essential to ensure uniform operation.

Once the organization of the rolling room has allotted definite, standardized tasks to each roll-breaker the only other thing which can be done is to allow sufficient time for each roll-breaking operation so that the operators do not have to rush the task. It is unlikely that feeding will be too slow, but a thin intermittent feed gives a high outturn of very uneven dhool. On the other hand a thin, continuous, well distributed feed gives the best working conditions. A rapid irregular feed with little or no attempt to break up or distribute the leaf evenly will result in a large part of the dhool being carried over the machine. Good roll breaking crews can do much to keep up a high standard of manufacture.

The main objectives in roll-breaking are three in number:—

1. To remove leaf which has been twisted off the rolled shoots (*i.e.* dhool) which clogs and impedes circulation and further twisting action on the larger leaf.
2. To prevent over fermentation of the dhool.
3. To cool the bulk of leaf when the temperature has risen *excessively* during the rolling period. Excessive cooling during roll-breaking is undesirable.

To some extent roll-breaking allows differentiation of fine and coarse leaf as there will be a tendency for the first dhool to contain large proportions of leaf from the most tender parts of the shoot. The tender leaf will bruise easily, and therefore ferment more quickly.

Roll-breaking should not be looked upon as a process for just removing fines from time to time; it should determine the extent of rolling carried out on the leaf. Failure to recognize the important part a roll-

TEA MANUFACTURE IN CEYLON

breaker plays may be the cause of many difficulties. A roll-breaker must be considered as important as, if not more important than any other machine in a tea factory. Yet, sad to relate, it is generally the most neglected.

To understand the significance of the roll-breaking operation, it may be as well to explain that the dhool extracted must be properly rolled. When leaf has reached a size which corresponds to that of a broken orange peoke (B.O.P.) grade when fired, it can for all general purposes be considered properly rolled. The two exceptions are when leaf grades have to be made and when a large outturn of the fannings grade is required. For these two requirements the size of the dhool must naturally be larger or smaller as the case may be, but if carried to excess a large proportion of such dhool will either consist of unrolled leaf or be unduly broken up in the rollers.

It is not difficult to comprehend why this should be so. If the mesh employed is too large, a part of the dhool which normally should have received more rolling is taken to the fermenting tables. On the other hand, should the mesh be too small, leaf that should have been dhool is put back in the rollers. The pernicious practice of using large mesh on roll-breakers to register high dhool outturns is a result of the emphasis placed on percentage dhool outturns. Reference has already been made to this aspect of rolling and it must be realized that such figures convey no information unless specified with mesh size. The function of a roll-breaker is extracting dhool, and not producing it. If insufficient dhool is obtained, the solution to the problem is not a larger roll-breaker mesh but more rolling.

A ball-breaker should be regarded as an integral part of a roll-breaker. It does not untwist the leaf as generally supposed and to condemn it on the grounds that it damages the leaf is nonsense, because far greater damage is actually effected when breaking up the balls by rubbing the leaf as it passes over the mesh.

The lack of a ball-breaker usually results in uneven dhool. Evenness of dhool should be one of the main objectives of roll-breaking because it makes for more even fermentation, better firing and less sifting when fired. However, in the case of a factory desiring to turn out a high percentage of leaf grades, too even a dhool is not advisable. The much sought after orange pekoe (O.P.) will most probably be lost together with the pekoe grade. With the exception of such cases a high standard of evenness of the dhool should be the general aim.

Roll-breakers do not happen to be standardized machines. Their speeds are variable and so are the size of the mesh and the slope of the trays. In consequence it is not surprising that various devices are resorted to in an attempt to obtain an even dhool. Double roll-breaking is certainly a good way of getting an uniform dhool but it involves more time more machines and more labour, and may lead to excessive cooling of the dhool. It is unnecessary to go to all this trouble when the same results can be got in a single operation by a suitable combination of mesh, speed and slope.

Mesh—To ensure even dhools the first requirements is to have mesh of different sizes on the roll-breaker tray. In the downward passage of the leaf the large particles tend to accumulate at the delivery end of the roll-breaker. A long tray, slow feeding, a low speed, or an unsatisfactory slope accentuates the effect. It is therefore advisable always to have a smaller mesh at the lower end. In spite of taking this precaution it will

ROLL-BREAKING

still be found that the size of the dhool is progressively larger from the feeding end to the other. It may then be found necessary to pass the last fraction of the dhool over the tray once again.

An argument often raised against the advisability of using coarse mesh at the top and finer mesh at the lower end is that most of the dhool would first pass through the former leaving practically nothing to pass the finer mesh. Unquestionably, this will happen if the meshes used are too coarse or too fine. Should meshes be arranged the other way round, with the finer mesh at the feeding end, most of the sifting action will take place nearest the bottom end of the roll-breaker, resulting in a most uneven dhool. If the tray is long, the particles will be so large as almost to resemble the coarse bulk that is normally returned to a roller for further rolling. Taking all these points into consideration, it is evident that the better arrangement is smaller mesh at the delivery end of a roll-breaker.

For low-country factories and some mid-country places an uniform dhool may actually be disadvantageous. The so-called "Kappy" or "Kambi" dhool made up of long twisted leaf, one of the components of a flowery broken orange pekoe (F.B.O.P.) grade, generally does not separate itself simultaneously with the smaller particles. If the maximum amount of this particular type of leaf is to be recovered, the leaf should remain longer on the roll-breaker tray. In this instance then the most satisfactory arrangement of mesh would appear to be the reverse of that recommended for obtaining uniform dhools, but in using coarser mesh at the delivery end, there is a risk of taking out unrolled leaf. The safest course of action is to have a tray of one size of mesh, but large enough to enable pekoe grades to be sifted out as well. It is not a good practice to double roll-break the bulk with this object in view because of the danger again of taking out under-rolled leaf with the dhool. A second sifting of the bulk is permissible only if,

- (1) the tray is too short,
 - (2) feeding has been too fast,
- or (3) the mesh used is too small.

Another practice which has nothing to recommend it, for reasons of insufficiently rolled leaf passing through the mesh, is that of rubbing the leaf over the tray. It sometimes takes the form of hindering the progress of the leaf by pushing it back. Another familiar device is to introduce raised battens to restrict the movement of the leaf. All these methods have arisen because of the undue importance attached to percentage dhool outturn. The appearance of the dhool instead of being the deciding factor has been relegated to the background. Roll-breaking can never be carried out successfully without due regard to the general appearance of the dhool, its size and its evenness.

Before proceeding further on the question of mesh size, attention must be drawn to the fact that dhool from the later rolls contains a larger proportion of fines than that from the earlier rolls. This is because the leaf gets more and more broken up as rolling is carried on. Under the same conditions of roll-breaking a later dhool will be more uniform than a dhool obtained in the earlier stages of rolling. It will also be smaller in size. A mesh that is suitable for early rolls may therefore not give the best results for the later dhools. The appearance and size of the dhool is also partly influenced by the nature of the leaf. The tougher types get broken very quickly in the rollers under pressure, whereas well twisted leaf is reduced to particles of a large size. Thus the choice of the correct

TEA MANUFACTURE IN CEYLON

size of mesh on a roll-breaker is a matter that requires the most careful consideration, as the success or failure of tea manufacture depends largely on it.

For the wide variations of leaf, wither, rolling technique, performance of roll-breakers, type of tea met with in Ceylon factories, a sweeping generalization cannot be made. The same mesh used on two identical roll-breakers may give totally different results. It is proposed therefore to give only an indication of what size mesh might give the best results under the varying conditions known to exist in Ceylon tea factories. The standard sizes of mesh now in use are Nos. 4, 5 and 6. Smaller or larger sizes are uncommon. There used to be a time when a combination of two or more different meshes was not in favour, but today such combinations are preferred to one single mesh owing to a recognition of the advantages obtained from taking uniform dhools.

For the purpose of making the best choice of mesh the following hints are given:—

1. Small mesh for liquors, large mesh for leafy grades. In case of doubt, No. 5 mesh will give average results.
2. If grades are to be small in size and cutting in the sifting stage reduced to a minimum No. 6, or a combination of Nos. 5 and 6, should be used.
3. When two or more different meshes are combined, the smallest mesh should be at the delivery end. The lengths used need not necessarily be equal; they may vary, depending on the dhool for which the roll-breaker is used, or on the method of operation.
4. As a rule, smaller mesh should be used for the earlier dhools, but in the case of low-country teas it should be the reverse of this.
5. A No. 4 mesh which suits low-country manufacture in the early stages of rolling, should never be used in an up-country factory, even in combination with smaller mesh.
6. The meshes likely to give the best results up-country are Nos. 5 and 6, suitably combined in the low-country, Nos. 4 and 5, either singly or in combination.
7. Leaf that readily breaks up in the rollers should never be passed over too small a mesh. If a combination of Nos. 5 and 6 proves too small, No. 5 alone should be used.
8. A long tray requires a combination of more different meshes than a short one to give uniform dhool. If a single mesh is used it will be necessary to resift the last fraction of the dhool.
9. If a tray is too long and despite a small mesh at the delivery end, dhools are too large in size, it may be made solid at that end.
10. If a tray is too short and dhool tends to escape with the bulk a larger mesh may correct it.
11. When all attempts have failed to get the desired effect by altering mesh size, the slope of the tray and the speed of the machine should be adjusted.
12. If a dhool is too large in size the slope should be made steeper or the speed increased. If too small, the speed or the slope should be decreased, or perhaps both.

ROLL-BREAKING

13. Altering the rate of feed is another way of compensating for incorrect mesh sizes or faulty performance of a roll-breaker, but it is important to remember that if a roll-breaker is fed too quickly some dhool goes over the mesh—if under-fed some bulk goes through.

14. Since the effectiveness of rolling is judged by the big bulk outturn, the size of the mesh used for the last dhools should be always taken into account. (See page 58).

The fact that, apart from the size of the mesh, the percentage outturn of the big bulk can be varied considerably by just varying the rate of feed is often ignored. If the leaf is fed very slowly, rubbed during the passage and the fraction going over the mesh re-sifted, quite a remarkable reduction in the percentage of big bulk can be procured. This is another example of the inadvisability of judging the efficiency of an operation by figures alone and finally,

15. Size of mesh must be correlated with gauge. Not always is the latter of a standard thickness and paradoxical results have at times been due to a discrepancy in the gauge of the wire,

General Suggestion—The following details may seem trivial, but they go a long way to make a success of roll-breaking:—

1. The tray should be level. Leaf should not be allowed to run on one side.

2. Mesh should not sag. The slightest tendency towards hollows should be corrected at the first opportunity by retensioning.

3. Mesh should be thoroughly cleaned each time it is used. If owing to an unsatisfactory wither, the mesh gets quickly clogged, the machine should be stopped and the mesh cleaned before roll-breaking is continued.

4. The tray must present a smooth surface. There should not be the slightest obstruction to the movement of the leaf.

5. Holes in the mesh should be repaired without delay.

6. The roll-breaker should be fed at an even rate and evenly across the tray.

7. Leaf should never be rubbed over the mesh,

8. The tray should be solid where the leaf falls on it from the hopper.

9. Roll-breaking should commence immediately the leaf is discharged from a roller. Leaf should not be left lying about for any length of time. If owing to faulty organization or lack of equipment, a delay is unavoidable, it should be turned over by hand frequently.

10. A beating apparatus for breaking up the balls is most desirable

Duration of Roll-breaking—One of the objects of roll-breaking is cooling of the leaf. Though of secondary importance, it cannot be overlooked. A mistaken notion is that the longer the time spent on roll breaking the cooler will be the leaf. It is perhaps forgotten that in these circumstances the mass of leaf awaiting roll-breaking remains longer in a heated condition. Time is precious in a rolling room, and every effort should be made not to waste it. Since a definite period is allotted to roll-breaking, just as in the case of rolling, every minute of that period must be usefully employed. A couple of minutes or as much as three are

WITHERING

taken up in cleaning the roller. This operation is sometimes carried out to excess in removing every particle of leaf. Such scrupulous attention is pointless. All that is required is cleaning away leaf caught between the batters or on the jacket. However, there is no need to keep the discharged bulk of leaf lying below the roller till this operation is completed. Roll-breaking should be started and the roller cleaned while roll-breaking is going on. It is the delay in taking the leaf from the roller to the roll-breaker that is usually the cause of hurried roll-breaking. When pressed for time the process can never be carried out efficiently.

The output of a roll-breaker is governed by the width of its tray. Modern machines are supplied in four standard sizes—3', 3½', 4' and 4½'. Under normal working conditions, their intakes of rolled leaf vary from 30 to 60 lb. per minute, more or less. Their individual capacities are given in Table XV.

Table XV. *Intake of a roll-breaker*

Size of machine (width of tray)	Intake—pounds approximately
3 feet	30
3½ feet	40
4 feet	50
4½ feet	60

These figures may be found useful for drawing up rolling programmes, which for their success must run on a definite time schedule. Allocation of time for roll-breaking naturally depends on the size of the roll-breaker and also on how long it takes to charge a roller. Badly matched rollers and roll-breakers disorganize the work. Since normally it takes 10 to 15 minutes to re-charge a roller, a roll-breaker should be sufficiently large to handle a charge of leaf within this period. In other words, the rate of roll-breaking should not be less than the rate of charging. The less time utilized for roll-breaking the more time available for cleaning the mesh in preparation for the next lot of leaf. For good work to be performed therefore, roll-breaker capacity should be in excess of actual requirements. The installation of machines which can handle a charge in 5 to 10 minutes will always pay in the long run.

Pre-firing Grading—The sub-division of dhools into fractions with idea of grading the tea before it is fired cannot be recommended. The very fine particles corresponding to a fannings grade produce a blanketing effect in the drier causing a damping down of the air flow. The very large particles have an opposite effect. For satisfactory firing, each of these types requires different conditions and when dhools of different sizes occupy the various trays of a firing machine, numerous adjustments have to be made. Handling of small amounts of leaf, which all have to be fermented and fired separately, is also an irksome task and adds to the new firing problems raised. On the whole, any system of grading the dhool in a green state is impracticable and not at all desirable.

CHAPTER 8

FERMENTATION

A description of the theory of the fermentation process was given in Chapter 1 from which it was seen that it is an enzymic process during which the tea juices are oxidized after the cells of the leaf are ruptured and for which oxygen is essential.

The object of fermentation is to bring about the changes necessary to make a tea liquor palatable. The liquor of unfermented tea leaf, in which the cells are freshly ruptured has a raw and green taste, which is sometimes described as metallic. During fermentation many complex changes take place, the chief effect of which is to give a mellow character to the liquor. As the process of oxidation and condensation continues, liquors become more colour and quality is developed, but beyond a certain point in the fermentation process quality starts to decline with an increasing gain in colour. When fermentation has proceeded too far the liquors become soft. Thus by reducing or increasing the period of fermentation, the degree of colour and quality can be varied to suit different requirements. If extended, more colour and less quality will result; if shortened, less colour is combined with more quality. These changes and effects are illustrated by the graph in Fig. 18.

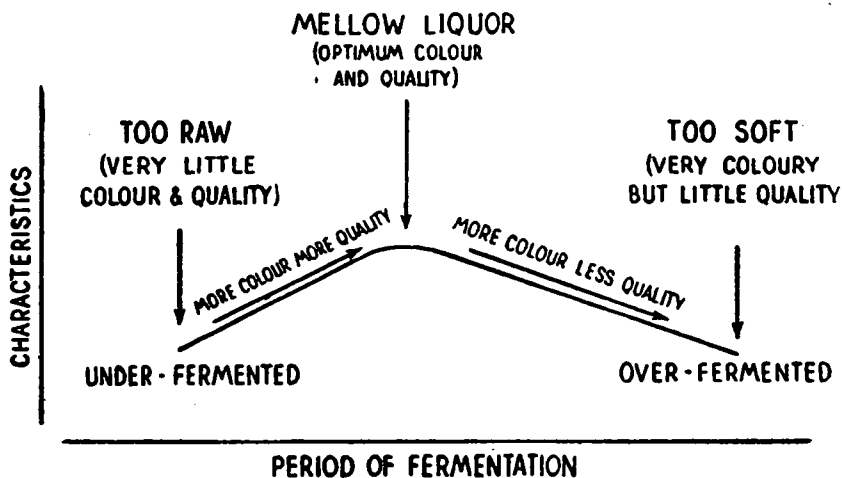

Fig. 18 Rough graph indicating the development of colour and quality during fermentation

Flavour is developed much more rapidly than quality and may completely disappear if fermentation is unduly prolonged. As a rule, it will be found that for the conservation of flavour the shortest possible fermentation is required.

Strength is a measure of the soluble matter in the liquor and is therefore mainly influenced by the extent to which the cells of the leaf are bruised and the expression of the sap on to the surface of the leaf. Its development on the fermenting racks appears to be significant only in the case of the early dhoos, but after some time insoluble products are formed, which result in the liquor becoming soft. The rate of formation of these compounds increases with temperature.

TEA MANUFACTURE IN CEYLON

Period of Fermentation and Temperature—From our knowledge of the changes occurring during fermentation, the principal conclusion is that the process is accelerated at a high temperature but arrested at very high temperatures.

According to biochemical studies on fermentation the optimum temperature for the activity of the enzyme chiefly responsible for the major changes lies between 80 and 90°F. It does not necessarily follow, however, that by fermenting tea leaf at these temperatures the most desirable oxidizable changes contributing to the taste of good tea are obtained. All the important characteristics of a tea are not developed at the same rate. Hence it may happen that whereas a rapid fermentation at a high temperature suits certain teas a longer fermentation at a lower temperature would prove more suitable for others. Anyway it is beyond all question that warmth is required for fermentation.

A major difficulty in trying to assess the true effect of temperature on fermentation of leaf rolled in the ordinary way is that we cannot with any precision say what changes take place during rolling. It should be remembered that the rupturing of the cells is a gradual process so that only those leaf tissues that are damaged which would actually ferment at the high temperatures attained in rolling. Undamaged leaf will be subject to a temperature which is harmful to quality. By the time all the cells of the leaf or most of them are ruptured a greater part of a roller charged would be unnecessarily heated up and undesirable chemical changes may take place. In simplest terms, what can be visualised as happening in a tea roller is that except for a small proportion of cells ruptured prior to a rise in temperature quite a considerable part of the bulk is pre-heated before fermentation proper starts. The continuation of fermentation of the dhools at a high temperature, particularly those from the later rolls, would therefore not be beneficial unless temperatures have been so low in rolling as to retard the process. Experimental evidence indicates that if sufficient warmth is obtained in rolling to start the oxidization of the juices released, no advantage, as far as quality is concerned, will result from exposing the dhool further to a high temperature however short the period may be. Colour may be improved but on the whole a short but rapid fermentation at a high temperature does not bring out the best of the properties which go to make a tea liquor.

Under the conditions rolling is carried out in most tea factories in Ceylon to-day the rolled leaf reaches such a high temperature that room temperatures are quite sufficient for fermentation of the dhool. Only in very exceptional cases might specially heated fermenting rooms prove helpful. The first requirement, however, for proper fermentation is to get the leaf warmed up as quickly as possible simultaneous with the maximum expression of juices.

In speaking of fermentation we have to consider not only the development of colour but other changes as well. How period affects these characteristics has already been shown, but in considering each dhool, in turn we are apt to overlook the variation in temperature each has been subjected to in the roller. It is only logical that the last dhool, for example, requires a shorter time on the fermenting racks than the first. Even then all dhools may not be fermented to the same extent, assuming the optimum period has been given to each. Some may have less colour than the others, or less quality, and so on.

Therefore, in determining the period for which leaf should be fermented, the first and foremost point to take into consideration is the extent to

FERMENTATION

which the main characteristics have been affected by rolling temperatures. The last dhool, for example, may have lost a greater part of its quality by the time it is transferred to the racks, in which case shortening its fermentation to improve this characteristic may not be of much help. Lengthening the period on the other hand may not improve colour if it has already been developed to the maximum degree.

The next point to consider, which is just as important but often ignored, is the amount of pressure applied on the leaf, which determines the extent to which the leaf tissues are broken up. Coarse leaf may very well ferment at the same rate as fine leaf if the same number of cells are ruptured in each case. The perceptible difference in the rate of fermentation between fine leaf and coarse leaf may not be entirely due to a difference in fermenting properties, but for the most part due to the ease with which the cells of fine leaf can be ruptured. It is for this reason coarse leaf requires more rolling than fine leaf, and probably a longer fermentation to get the same degree of colour normally associated with tender leaf. It is very probable of course that because of the variability of the enzymic content in different parts of the flush, tea juices from finer leaf having a higher enzymic content would ferment faster than coarse leaf. So it will be seen that apart from temperature, and the amount of juice expressed, another factor of equal importance is the fermenting property of the leaf.

Teas which by their nature are light in colour of cup depend for their value on quality and flavour, and it will never pay to sacrifice part of these characteristics by extending the period of fermentation in order to obtain more colour. It will not be possible even with harder rolling or increased temperatures to obtain a sufficiency of colour to bring the tea into the category of coloury liquors. It would be an attempt at the unattainable. In such a case instead of trying to improve colour the shortest possible fermentation should be given in order to conserve quality.

Should light liquors be not an inherent character and teas lack colour after normal fermentation, lengthening the period of fermentation will only lead to softness without an appreciable change in the colour because whatever the amount of juice liberated from the leaf it will still ferment at the same rate. The only remedy is more rolling.

From the fact that tea juices from different dhools may ferment at different rates because of the variation of the enzymic content and essential constituents, the optimum period of fermentation cannot obviously be the same for each dhool. Besides, no two dhools under existing rolling conditions are fermented at the same temperature. Where hard rolling is practised it will generally be found that the earlier dhools ferment the fastest, whereas just the opposite takes place when lighter rolling is adopted in the initial stages. The correct order of firing the dhools is therefore a matter that can best be determined by the system of rolling adopted and the fermenting properties of the leaf.

The period of fermentation will lose much of its significance if the period of fermentation of each dhool is not taken into account. If only say 40 minutes is allowed for firing a batch of leaf and firing commenced $2\frac{1}{2}$ hours after rolling, the first dhool, if fired last, will be fermented for a little over 3 hours, whereas if the changing interval is 2 hours, the same first dhool will receive $4\frac{1}{2}$ hours fermentation. Should the order of firing be reversed entirely different periods will be brought about. It is therefore necessary to examine both charging interval and order of firing before attempting to estimate the effect of any system of fermentation.

TEA MANUFACTURE IN CEYLON

Charging Interval and order of Firing Dhools—It has just been shown that if all the leaf from a particular batch has to be fermented to the same extent, each dhool should be given a different period of fermentation. It has also been shown that during the process of fermentation a point is reached when colour and quality are developed to an optimum degree, after which a gain in colour is obtained at the expense of quality (See Fig. 18). At certain elevations or at certain times of the year, however, an all round liquor may not be preferred to one in which either colour or quality is the most prominent feature. By a suitable adjustment of the period of fermentation we can expect to develop either characteristic to a mark degree. This feature in a tea liquor can be obtained by an adjustment in the period of fermentation but as it is not just one dhool but different dhools that are affected it is not such a simple matter as all that. The length of the charging interval limits the scope of adjustment.

The best way of explaining this is by giving a few examples, but before doing so it is necessary to know for how long tea can be fermented without seriously impairing its desirable characteristics at normal room temperatures of 65-75°F. after having reached a temperature of 80-100°F. in the rollers. Ignoring the peculiar fermenting properties of some leaf, it will be found that under the conditions obtaining in average Ceylon tea factories a serious loss of quality occurs after about 4½ hours and liquors are too green and raw up to about 2½ hours. If fermentation periods of the different dhools and of B.B. lie within this range there is no serious risk of under-fermenting or over-fermenting a whole batch of leaf.

When flavour is prominent, periods shorter than 2½ hours may be adopted for the first dhool, and any greenness that may result will barely be noticeable when it is bulked with the other dhools. The contribution that fermentation period makes to a liquor depends therefore on the percentage outturn of dhool. An alteration in the period of fermentation of a dhool with a very large outturn will have a very much more marked effect on the tea as a whole than a change in the time of fermentation of a dhool with a small outturn. The effect on the latter itself may be noticeable, but negligible as far as the whole batch of leaf is concerned.

These effects in conjunction with variable factors such as jat, wither and temperature show the utter absurdity of finical attention being paid to small adjustments in period of fermentation. Provided fermentation is long enough to allow the enzyme to oxidize the juice a change of even 15 minutes will have no appreciable effect. To know when this stage is reached is a matter for experience and judgement since fermentation varies with different types of leaf and different temperatures. On an average it takes about 3 hours. With this figure as a basis the following examples are given to show the manner in which charging interval can affect the period of fermentation of each dhool and of the batch as a whole.

Example 1.—Short charging interval of 40 minutes. Percentage dhool outturns 10, 20, 25, 35 and B.B. 10. Order of firing dhools, B.B., 4, 3, 2, 1. If firing commences at 3 hours from time of rolling, periods of fermentation will be as follows:—

Dhool 1	3.35 hours (approx.)		
" 2	3.30	"	"
" 3	3.20	"	"
" 4	3.05	"	"
" B.B.	3.00	"	"

FERMENTATION

Example 2.—If the order of firing is reversed:

Dhool 1	will be fermented	3.00	hours		
” 2	” ”	3.05	”	(approx.)	
” 3	” ”	3.15	”	”	”
” 4	” ”	3.30	”	”	”
B.B.	” ”	3.35	”	”	”

When these figures are examined it will be seen that dhool 3 has received the same period of fermentation in both examples, the earlier dhools of example 1 have been fermented longer, but the 4th dhool shorter than in example 2. Since in each example the difference in fermentation is only about half an hour the bulked dhools will not show a marked difference. Of course, if only the 1st and 2nd dhools and dhool 4 were considered separately, the earlier dhools in example 1 will have more colour and the last dhool less colour than those in example 2.

Example 3.—Long charging interval—2 hours. Percentage dhool outturns, order of firing and fermentation as in example 1.

Dhool 1	will get	4.50	hours	fermentation
” 2	” ”	4.25	”	”
” 3	” ”	3.55	”	”
” 4	” ”	3.10	”	”
B.B.	” ”	3.00	”	”

Comparison with example 1 shows a marked difference, each of the first 3 dhools having received a considerably longer fermentation, although the computed period of fermentation of 3 hours was the same in each case. The earlier dhools would be over-fermented and possibly the 3rd as well.

Example 4.—Same as in example 3, but order of firing reversed. Fermentation periods would then be as follows:—

Dhool 1	3.00	hours
” 2	3.10	”
” 3	3.35	”
” 4	4.05	”
B.B.	4.50	”

In comparison with example 3, a smaller proportion of the tea is likely to be over-fermented. The bulked dhools should, therefore give more quality, but less colour, but compared with either example 1 or 2, the tea as a whole will possess less quality but more colour.

If in the last example the 4th dhool has to receive a normal fermentation of 3 hours, the first dhool will have to be taken to the drier 2 hours after rolling. It will then be under-fermented, and this probably also applies to the second dhool.

In example 3, no such shortening is possible because the 4th dhool or B.B. will not be available till nearly 3 hours after the commencement of rolling.

It must be accepted then that the key to successful fermentation is a correct charging interval. In general, a short interval is preferable for quality teas. The only strong point in a long interval is the extra colour.

TEA MANUFACTURE IN CEYLON

The strength of a liquor is unlikely to be affected to any marked extent by the length of the charging interval provided the period of fermentation is within reasonable limits.

The second factor of importance is the order in which the dhools are fired. As will be seen from the examples just given, the character of a tea can be noticeably altered by a change in the firing order taken in conjunction with the charging interval. It is a simple matter to arrive at the correct order by observation of the fermentation of each dhool on the racks and again in the liquors. Even then it may not be possible to give each dhool its optimum period of fermentation. However, in the case of a factory using two driers or three, more opportunities exist for obtaining the most suitable periods. For example, instead of dividing the dhools into two driers at the same time, as is customary, two different dhools may be fired simultaneously. Another possible modification is to bring one drier into operation later than the other, which will be tantamount to extending the charging interval.

Next in importance to period of fermentation is humidity. All other external factors such as nature of the fermenting surface, thickness of spread, and density of spread produce a negligible effect in comparison.

Humidity—The oxidative processes involved in fermentation can only take place in the presence of water. Removal of water, or drying beyond certain limits will first slow down and finally inhibit the action. Fermenting leaf must therefore be kept moist. Leaf spread on the fermenting table is prone to superficial drying, and this checks fermentation in the exposed leaf and causes uneven fermentation. To avoid this drying, most fermenting rooms are humidified, but it is necessary, however, to bear in mind that existing systems of humidification lower the temperature of the air. It is probable that this decrease in temperature partly offsets the benefits of high humidity. This being the case the importance attached to a little drying on the surface caused by higher temperatures and lower humidities should not be over-estimated.

One method employed for reducing the effect of surface drying is turning over the leaf. Actually, this treatment does more harm than good because each time this operation is done the leaf is cooled with a consequent retardation in fermentation. Another method, but not so common, is to spread a wet cloth on the surface. It produces an exactly similar effect as the previous method and should be avoided.

Addition of water to dhools with the same object in view cannot be recommended. The disadvantage of this expedient is clear. Not only is the cell sap diluted but the evaporation of this water reduces the temperature of the leaf.

None of these practices is sound. If surface drying is to be reduced to a minimum the best method appears to be to spread thickly.

Thickness of Spread—A thicker spread reduces the surface area exposed to the drying effect of the air. It also maintains the leaf at a higher temperature because less evaporation takes place of moisture from the leaf. In consequence fermentation is accelerated. Thin spreading has the opposite effect. A thicker spread to give the best results should therefore be accompanied by a fermentation shorter than that considered adequate for a thinner spread.

FERMENTATION

Contrary to popular belief, excessive cooling of the dhool is not all desirable and although a certain amount of cooling does take place on roll-breaking, the temperature of the leaf will be found to be higher than that of the atmosphere. After transference of the dhool to the racks the temperature may rise or fall according to the conditions prevailing. Hot, stuffy conditions may tend to raise it to a dangerous level if spreading is too thick. If spreading is too thin the leaf cools rapidly in a dry atmosphere and the little heat generated by fermentation will not be able to replace the heat dissipated by evaporation of moisture. Under average conditions, that is to say with a humidifying appliance operating and a hygrometric difference of 2 to 3°, and leaf spread at a thickness of 1½ to 2 inches, there is a very little change in the temperature on the leaf during fermentation. The figures in table XVI give an idea of the temperature changes in leaf from the time it is rolled until it is ready for firing.

Table XVI. *Temperature changes in leaf after rolling.*

	EXAMPLE		
	1	2	3
1. Room temperature	50°F	60°F	70°F
2. Temperature of leaf at end of roll	75°F	83°F	88°F
3. Temperature of leaf after roll-breaking	64°F	70°F	76°F
4. Temperature of leaf at end of fermentation. (3 hours approx.)	62°F	67°F	74°F

It will be noted that in each case the temperature of the dhool was maintained at more or less a constant level. Another interesting feature is that the difference in temperature between that of the fermenting leaf and that of the room was greatest when the latter was lowest. This was because of a bigger temperature rise in the roller—25° as against 18° at a room temperature of 70°. The drop in temperature after roll-breaking was about the same in each case, being 11 to 13°. Nevertheless, the higher temperature attained by the leaf in rolling helped to keep it at a temperature higher than that of the rolling room for a considerable time after it had been sifted.

The important part played by the heat developed in the rollers explains how fermentation is obtained even at low atmospheric temperatures. In the particular example given the bigger increase of 25° in the roller was brought about by increased pressure. Had the leaf been lightly rolled very little fermentation would have taken place.

When considering fermentation the point that must not escape attention is the temperature of the leaf. If fermentation after roll-breaking is not to be retarded by cooler conditions of a rolling room, dhool should be transferred as quickly as possible to the fermenting racks. It must be spread as thickly as possible to retain whatever heat it possesses but not heaped beyond a depth that would restrict the access of air to the lower layers. A 3 inch thickness of spread is the maximum that can be resorted to.

TEA MANUFACTURE IN CEYLON

Fermenting Surface—As far as evidence goes, the only connection between the nature of a fermenting surface and of the liquor obtained is in respect of the cleanliness of the former. A contaminated surface is very likely to result in softer teas with more colour, especially if fermentation is lengthened. This is due to the effect of the micro-organisms present on tea leaves.

The effect of bacteria may not be marked for the short periods leaf is fermented, but the risk of a detrimental effect taking place at any time cannot be overlooked. The likelihood of undesirable characteristics arising from bacterial fermentation is always present in an unclean surface, whatever may be the necessity of the presence of stale tea juices for the production of certain favourable qualities in tea. Maltiness is believed to be one of these, but the indications are that it is more an inherent character of the leaf than the result of some modification in manufacture.

It is beyond all question that the organisms in stale leaf produce disagreeable substances. For the relatively hard withers taken in Ceylon the likelihood of a thin coating of dried tea juice on a fermenting surface having a harmful effect is remote. Nevertheless, cleanliness is called for. Precautions should be taken in time to prevent thick crusts forming on fermenting surfaces and developing an acid odour, which may give rise to sour liquors. Fermenting surfaces should be free from cracks and holds, washed daily and frequently scrubbed thoroughly. Disinfectants should be avoided. The use of plain water and plenty of it after the day's work will make the leaf safe from bacterial infection. Rollers, troughs, roll-breakers and floors should receive similar treatment.

With regard to the type of fermenting surface, tea appears to ferment equally well on either glass, metal, wood, asbestos, cement or plastic. The choice depends on cost of the material and on how easily it can be kept clean. Cement and aluminium offer the most suitable surface, being the cheapest and most convenient.

Density of Spread—The way in which this affects fermentation is partly by its connection with temperature and partly by its relation to the accessibility of air. Compact spreading is not advisable in the case of thick spreading; it can be recommended only if spreading is so thin as to result in excessive cooling of the leaf.

As a guide to the rate of spread some figures are given in Table XVII corresponding to various thicknesses.

Table XVII. *Rate of spread for various thicknesses.*

Spread inches	WEIGHT OF LEAF PER SQUARE FOOT	
	Normal	Maximum permissible (Pounds approximately)
1	1½	3
1½	2	4
2	2½	4
2½	3½	4½
3	4½	4½

This will vary according to the size of the leaf particles, since fine leaf will occupy a less volume than coarser leaf. The figures given apply

FERMENTATION

to normal size dhool through a No, 5 roll-breaker mesh from an average wither. They will therefore not be the same for all factories. However they may prove a useful guide for those estate where some doubt exists about the density of spread for fermentation. The general rules are:—

1. Loose spreading for fine dhools, compact spreading for coarser dhools.
2. Loose spreading for thick layers of leaf and compact when the spreading is thin.

Judgement of fermentation—During fermentation two perceptible changes occur, one in colour and the other in aroma. The most favourable point in fermentation is supposed to be reached when the colour and so-called “nose” (aroma) come up together. To assess fermentation on this basis requires experience and judgment of a very high order.

Colour by itself is a misleading guide because if the wither is hard the leaf will look green no matter how long it is left on the fermenting racks and if the wither is soft it quickly acquires a coppery hue. The conspicuous presence of stalk in a last dhool may also give the impression that the dhool is well fermented whereas it may not actually be the case,

It is best therefore to judge the degree of fermentation by the taste and colour of a liquor. The colour of the infused leaf can at times prove to be very deceptive. To assume from a greenish infusion that fermentation is not completed is most risky. Rawness and softness in the liquor are the only reliable sign-posts.

CHAPTER 9

FIRING

The object of firing is to check fermentation by the removal of the moisture from the leaf. This is accomplished by a current of hot air.

In the process of firing another change takes place in the tea. It acquires a mellower character. This is probably due to the further fermentation that takes place at the higher temperature before the tea is dried. Fermentation continues even after a tea is fired because it contains some moisture and slow oxidation is possible in the presence of moisture. This action known as post-fermentation increases with percentage moisture content, and will ultimately lead to the tea 'going off' if the moisture content is too high.

The temperature at which tea is fired also affects keeping quality. If it is insufficiently high the keeping qualities of the tea suffer. On the other hand if it's too high, and the tea is dried rapidly a condition referred to as "case-hardening" results, in which the surface of the tea dries up quicker than the core, imprisoning some of the moisture inside. In such a case the tea may appear to be well fired, but owing to the extra moisture it contains it will not keep as long as a properly fired tea.

Firing to very low moisture contents also has its drawbacks. Besides being uneconomic to do so, it necessitates the exposure of the tea to a high temperature longer than is good for quality.

The three essential requirements for proper firing, therefore, are:—

- (1) controlled temperature,
- (2) controlled rate of moisture evaporation,
- and (3) controlled moisture content of the final product.

The modern firing machine consisting of six moveable trays operated mechanically meets these requirements. When the machine is full of leaf, the top tray into which the leaf is introduced is exposed to a lower temperature than the leaf on the bottom tray, which has then almost reached the dry stage. The efficiency of the drying operation is judged by the rate of loss of water on each tray and the moisture content of the discharged tea.

The factors which influence the process are:—

- (a) temperature of air,
- (b) volume of air,
- (c) amount of leaf on each tray (or amount fed into the drier)
- and (d) time taken (length of exposure to hot air.)

To understand the influence of each of these it is necessary to know something of the physical process of tea drying under the conditions in which a drier operates.

The Technology of Tea Drying—The technology of tea drying is somewhat more complicated than it appears to be at first sight. The design of a firing machine is such that at each stage of the firing operation tea is subject to a different temperature. As the leaf progresses through the machine from tray to tray it meets a progressively higher temperature.

It may be wondered why the whole operation cannot be performed by the utilization of only one tray. One reason is that the freshly fed

FIRING

dhool will receive the full temperature of the hot air with consequent tendency to case-hardening. The other is the excessive waste of heat. In an ordinary tea drier, owing to the trays being situated one above the other, much economy of heat is effected.

It was pointed out in an earlier chapter that when air takes up moisture its dry bulb temperature drops. The greater the amount of moisture absorbed by the air the greater the fall in the temperature. The exhaust temperature therefore gives a fairly good measure of the amount of evaporation that takes place, and is of considerable importance in the firing process. It not only indicates the thermal efficiency of a drier, but also the conditions on the top tray.

The primary object of firing being the arrestment of fermentation the initial temperature to which leaf should be exposed must be high enough to inhibit the process, otherwise fermentation will continue for a considerable time at a very rapid rate, causing softness in the liquor to an excessive degree with a loss of soluble matter and essential oils. This is generally referred to as "stewing". To prevent such over-fermentation a temperature of at least 140°F is required. This condition is satisfied when the temperature of the air leaving the drier is round about 125°F. Even at this temperature enzymes are not immediately and completely destroyed. Some oxidation takes place, but it appears to mellow the liquor. There is reason to believe that, if a much higher exhaust temperature is maintained, fermentation is checked so rapidly that teas will be open to criticism on grounds of harshness. The other danger is the likelihood of case-hardening occurring, reference to which was made earlier.

In any case, high exhaust temperatures cannot be recommended because of the loss of valuable heat. The thermal efficiency of a drier is measured by the difference between the inlet and exhaust temperatures. The greater the temperature drop, the higher the efficiency. But, in the case of the firing of tea the efficiency of the operation has to be considered in relation to the actual temperature at the exhaust in conjunction with the moisture content of the made tea. If the exhaust temperature is lower than what it should be the moisture content of the tea will be high. When an exhaust temperature of about 125°F is obtained, firing can be regarded as being carried out on proper and economical lines. The tea is then discharged at the optimum moisture content of about 2½ to 3% and optimum conditions exist on the top tray of the machine for the checking of fermentation.

Moisture is not lost at an even rate as leaf passes from tray to tray in a drier. As the leaf gets drier, it offers more resistance to the evaporation of water. Most of the evaporation takes place on the early trays and towards the end of the drying process it is hardly noticeable. The gradient of drying through the machine is shown in the form of a curve (Fig. 19) in which percentage moisture content is plotted against each row of trays.

The greater evaporation in the initial stages of drying is indicated by the steep line. When the moisture in the leaf is reduced, the curve flattens out. The graph represents typical firing conditions in a modern drier operating at an inlet temperature of 190°-195°F and an exhaust of 120°-130°F.

Firing Temperature—Tea can be fired, without any serious detrimental effects, at temperatures varying from 160° to 210°F, provided the period of drying, load of leaf, and volume of air are suitably adjusted

TEA MANUFACTURE IN CEYLON

to discharge the tea at the correct moisture content. From the economic viewpoint higher temperatures will naturally be preferred, but it has been found that two important characteristics of tea, namely, quality and flavour, when present, depreciate with an increase in the firing

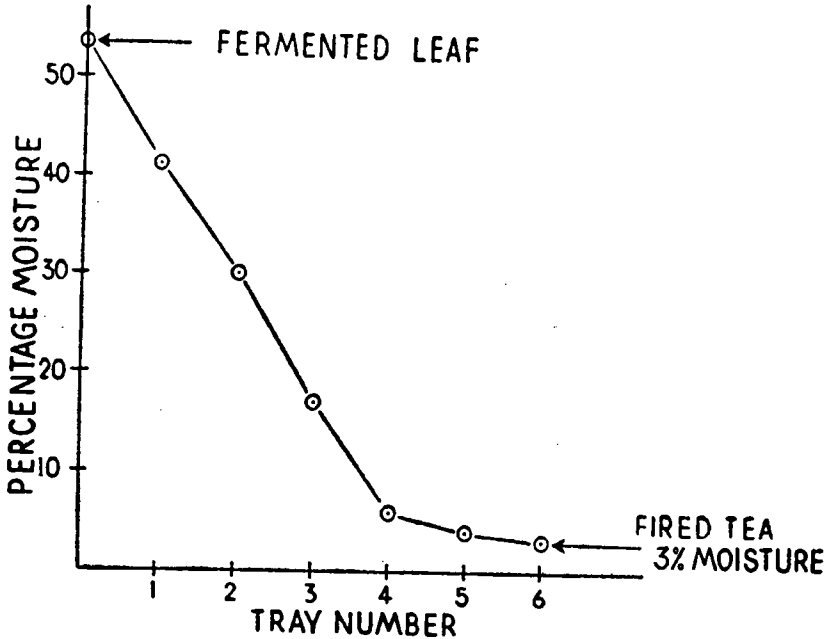

FIG. 19. Normal drying curve for an exhaust temperature of 120—130°F

temperature. It has also been found that, though low firing temperatures are favourable to the retention of any quality or flavour in the leaf, the keeping properties of the product are impaired.

The best firing temperature is no longer a matter of controversy. It has been proved that firing at 190-195°F. gives the best all-round results. Slightly lower temperatures may be employed at the height of a flavoury season, but a temperature of 180°F is the lowest limit. At low elevations, where the boiling point of water is much higher, and high grown quality absent, tea may be safely fired at a higher temperature, but certainly at not more than 210°F.

Volume of Air.—This is a very important, but neglected factor in firing and a considerable number of the problems in firing may be traceable to an inadequate air supply.

The evaporative capacity of a drier is governed by the quantity of heat available, which in turn depends on the temperature and the amount of air delivered. If this is below normal requirements the temperature has to be increased to give the equivalent amount of heat. When a machine fails to give the rated output a common practice is to raise the temperature, a familiar ruse which is resorted to when the wither happens to be soft or the working day long.

Generally speaking, insufficient air in a drier is more often than not caused by a fan running at too low a speed. A small exhaust duct may produce a similar state of affairs, as a result of a back pressure being set

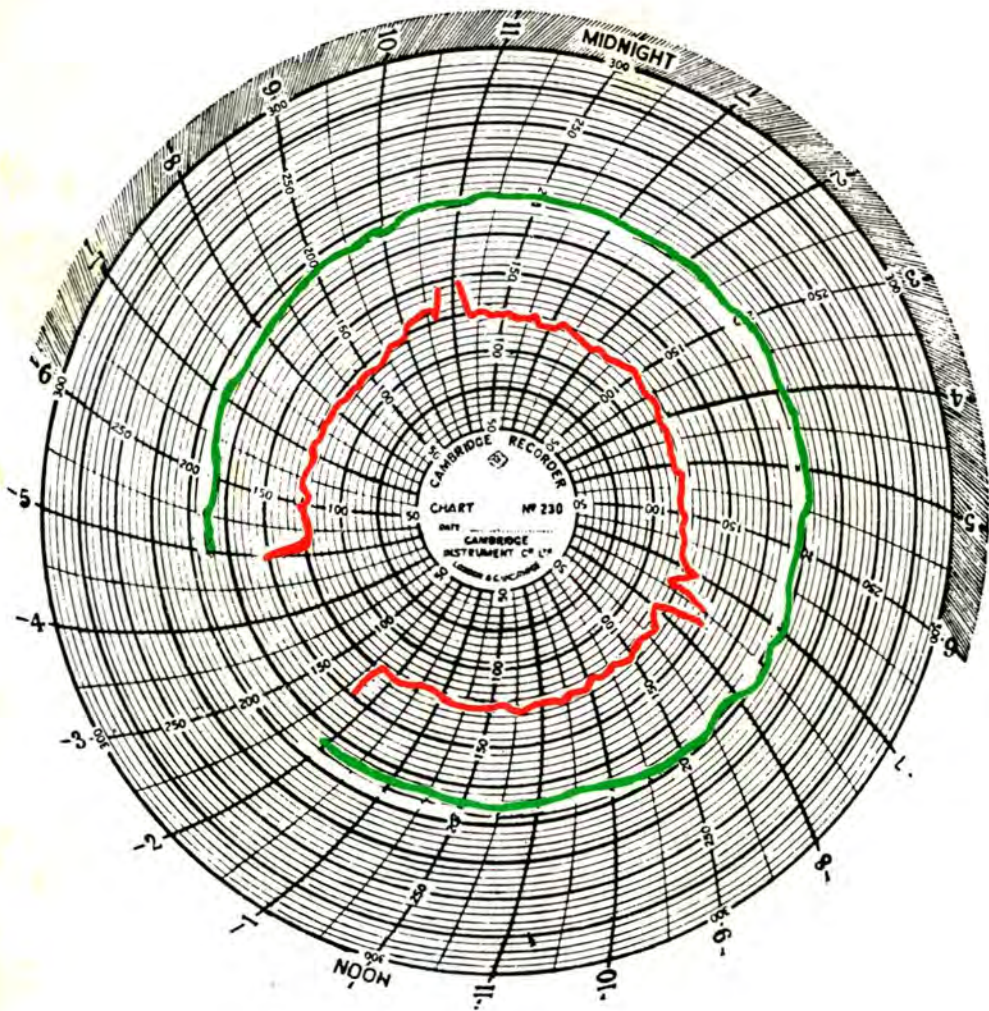

Plate IV — Sample record of inlet and exhaust temperatures under actual working conditions on three successive days.

FIRING

up, which reduces the efficiency of the fan. Very small tray perforations affect the flow of air in a like manner. Working a drier with the fan valve partly closed because of excessive 'blow out' is another cause.

Any of these troubles should receive early attention. Since a drier is the most expensive machine in a tea factory and costly to run, every effort should be made to get the maximum output of tea from it with an adequate volume of air.

Load of Leaf—Over-loading of driers is a common fault and has to be compensated for by a higher firing temperature and a longer period of drying. It also sets up a back-pressure baffling the air flow and results in an uneven drying. The general effects are loss in quality and irregular infusions.

The spread should be of a reasonable thickness to permit the air to pass freely through it and could best be judged by the movement of the leaf particles in the stream of air. If no disturbance is observed it may be assumed that either the leaf has been spread too thickly or the air flow is insufficient.

The thinnest economical spread, but not so thin as to form vacant spots, should whenever possible be adopted and full use made of the internal and auxiliary spreaders. An even spread on the feeding trays of an automatic drier does not necessarily indicate that the same conditions exist on the firing trays because when leaf falls from one tray to another it tends to form into ridges. The leaf should be levelled out by the internal spreaders provided, which have to be carefully adjusted according to the thickness of spread. If they are raised too high they will be ineffective; if lowered too much, leaf accumulating behind them will give rise to stewing conditions or over-firing in the case of the lower trays. Well spread leaf of the correct thickness should present a uniform appearance on all trays with some signs of disturbance.

Big bulk requires a slightly longer period of firing than fine dhool and should be spread thicker. If this is not done more air will escape through the larger spaces between the particles. If it is not spread closely, a part of the air is unused and escapes with the rest of the air to the exhaust. The exhaust temperature then rises giving an entirely false indication of the conditions inside the drier. The more air that escapes in this fashion, the less drying the tea receives. Coarse dhool should also be fired at a higher spreader setting than a fine dhool. In general, later dhools because of their fineness should be spread the thinnest, the early dhools a little thicker, and the big bulk the thickest of all. If this is correctly done, the exhaust temperature will remain steady.

Not only for different dhools are spreader adjustments necessary. A firing machine under fixed conditions of inlet temperature and volume of air is capable of evaporating only a certain amount of water. It is therefore obvious that if a drier is to function efficiently the load should be reduced for soft withers and increased for hard withers. Under no circumstances should firing be attempted on a set spreader position. A firing machine cannot be expected to adjust itself automatically to suit different types of leaf and variations in wither. Load must therefore be varied for good firing to result. The exhaust temperature may be taken as the guide. If it goes down it is a warning that the drier is over-loaded; if it goes up, the load requires increasing. Intelligent anticipation of a small rise or fall in the temperature will ensure correct loading of the drier.

Period of drying—The time required to dry tea varies with temperature and load. The volume of air employed also affects it.

TEA MANUFACTURE IN CEYLON

According to experimental evidence it takes approximately twice as long to fire a tea at 160°F as to fire it at 190°F, load and air flow remaining constant. If the load is halved for the lower temperature, the time of firing is the same in each case. At higher temperatures the rate of loading can be proportionately increased to give the same moisture content in the made tea; or by having a set load the period of drying can be shortened. The relationship between these variables, keeping two factors constant, for three levels of temperatures is shown in Table XVIII.

Table XVIII. *Relationship between temperature of firing, load and period of drying.*

(A) LOAD AND AIR FLOW CONSTANT

At 160°F—42 minutes to fire

“ 190°F—21 “ “ “

“ 210°F—15 “ “ “

(B) TIME AND AIR FLOW CONSTANT (Time of firing 21 minutes in each case) Rate of loading:...

At 160°F—half that at 190°F, and one-third that 210°F.

From these figures it is evident how wide the variation in the firing period can be even if temperature is kept constant. For example, at 160°F, firing time is shortened from 42 minutes to 21 minutes by halving the rate of loading. It has been found that this relationship of load and time holds good for higher temperatures as well, provided spreading is not unduly thickened for shorter periods of firing.

The question of the time required to dry tea ultimately boils down to the load. If this is small the period of drying can be shortened and *vice versa*. But two considerations are (1) too small a load is wasteful of heat, (2) too big a load causes uneven firing. A compromise between the two is what is required.

Experimental evidence supported by experience shows that if the period is 19 to 21 minutes for a firing temperature of 190-195°F, the thickness of spread is at its optimum for economical working and retention of quality. At a higher or lower temperature, but for the same thickness of spread, the period will of course have to be altered. At 200°F, it may have to be approximately 15 minutes and at 180°F 24 minutes, more or less.

Whatever combination of temperature and time is employed the exhaust temperature should not read less than 110°F. If it is less than this figure, the air flow may be inadequate, or the load too much or it may be that the teas are passing through the machine too quickly. Each of these probable causes should be investigated in turn before raising of the inlet temperature is contemplated. Should the exhaust be more than 130°F the spreading can be thickened or the period reduced or both adjusted to offset extra air flow. A safer expedient, without having to alter load or time, is reducing the volume of air by partially closing the fan-valve.

Even in the case of big bulk the same exhaust temperature is required for satisfactory firing and can be obtained by a thicker load and by firing on a slower pulley.

The Exhaust Temperature—Why the exhaust temperature regulate the firing process has already been made clear. If it is too low, stewing conditions arise on the top trays; if it is too high, it may lead to case hardening. For the normal range of firing temperatures of 180-200°F, an exhaust temperature of 120 to 130°F not only provides the optimum conditions for the inactivation of the enzymes, but also ensures that the tea is discharged at the correct moisture content. Figure 19

FIRING

showed the drying gradient for tea fired under such conditions. It may be of interest to know what takes place at lower or higher exhaust temperatures.

In Fig. 20, which represents tea fired with an exhaust temperature of 110°F, the notable features are:

- (1) the less evaporation on the top trays (stewing conditions)
- (2) the higher moisture content of the made tea.

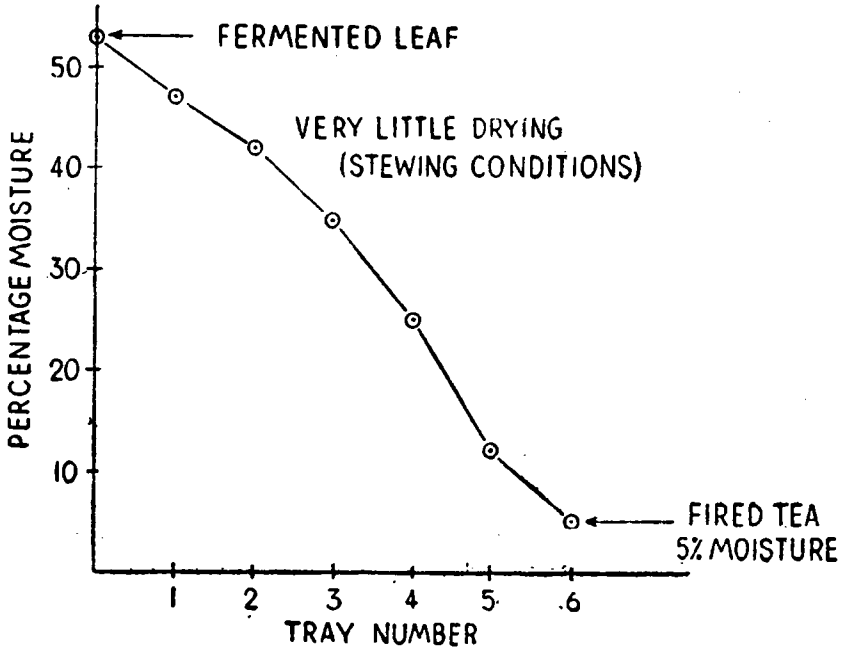

FIG. 20. Drying curve for an exhaust temperature of about 110°F

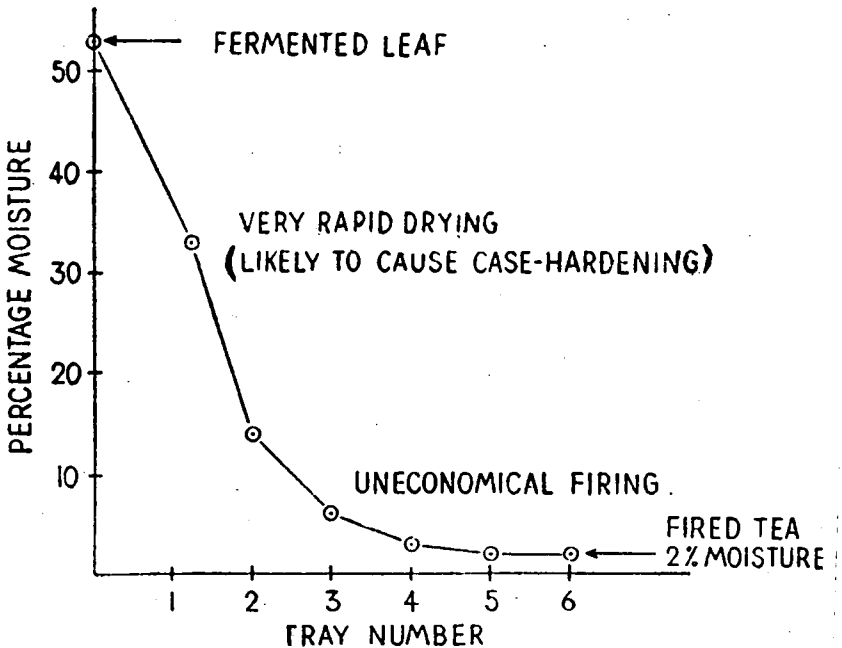

FIG. 21. Drying curve for an exhaust temperature of about 140°F

TEA MANUFACTURE IN CEYLON

The curve in Fig. 21 which shows the result of an exhaust temperature of 140°F, is almost the exact opposite of that in Fig. 20. The most important point to note is that in comparison with the curve in Fig. 19, the moisture content of the discharged tea is only 1% less, and this has been attained at the expense of an amount of heat out of all proportion to the small drop in moisture. The curve also shows up the rapid drying in the early stages, likely to cause the defect known as case-hardening.

Since exhaust temperature plays such an important part in firing, the thermometer recording it should be placed in the correct position. If the bulb of the thermometer is more than a few inches above the leaf, there is a risk of moisture condensing on it and thus lowering the temperature. The thermometer should be fixed as close as possible to the centre of the top tray area. If placed near the edge as is sometimes done, a higher temperature than is really the case may be recorded owing to the hot air escaping from the sides, and by-passing the leaf. False readings may also be obtained by uneven spreading in a tilting tray type of drier or irregular spreading in an endless chain machine. Another cause of erroneous exhaust temperatures arises from excessive air speeds, which result in undue disturbance of the leaf. The possibility of a thermometer not being accurate should also not be overlooked, and it is strongly advised that its accuracy be checked from time to time either by comparison with a standard thermometer or immersion in boiling water if its range of temperature permits such a test. Appendix F gives the boiling point of water at different elevations.

In all these cases just mentioned the exhaust reading cannot obviously be relied upon, and temperatures of 120-130°F will therefore not hold good for satisfactory firing. It will then be of vital importance to have the defect rectified.

In machines where it is not possible to place a thermometer in the exhaust, it may be fixed above the second row of trays. In this position it should record a temperature of at least 140°F.

The maximum range of exhaust temperature that can be permitted in an endless chain machine is 10°, and must be within plus or minus 5° of 125°F. It is quite impracticable to have a perfectly steady temperature, but for correct firing the fluctuations should be small. A record of temperatures actually obtained at St. Coombs factory and typical of firing conditions daily is reproduced in Plate IV. The chart shows what can be achieved by careful supervision of the firing process. The exhaust temperature shows little variation whilst the trace of the inlet is almost as perfect as one would desire.

In a tilting tray type the range is larger because conditions of operation are entirely different. Each time a row of trays is emptied and replenished with leaf the temperature rises and falls rapidly. The thermometers that are usually supplied to driers are not sensitive enough to record these changes accurately, and even with careful firing it will not be unusual to note a temperature difference of 20° within a cycle. A range of 115 to 135°F is allowable.

The Moisture Content of Fired Tea—One of the objects of firing is to convert the fermented leaf to a stable product in order to stop deterioration. Unfortunately, dry tea is not completely stable and is liable to slow oxidation in the presence of air dependent on the amount of moisture present. It must be inferred, therefore, that the lower the moisture content tea is fired to, the less liable it is to deterioration. The disadvantages of firing to a very low moisture content were discussed.

FIRING

earlier in this chapter. It is therefore necessary to discuss the highest limit, and this is linked with the property tea possesses of absorbing moisture.

After tea is fired, it absorbs moisture from the air during the process of grading and picking and again during storage and transit. The gain in moisture by the time the tea reaches the market is 2 to 3% on the average. If the moisture content goes over 6% the tea rapidly deteriorates. The safe limit for the moisture content of fired tea is therefore in the region of 3%.

In factories where humid conditions prevail a very great risk is run if this figure is exceeded. Long before the tea has reached the packing stage it will have absorbed sufficient moisture to bring up the moisture content to the danger zone of 6% and over. The tea will then have to be refired to check the deterioration that has started. The fact that one can fall back upon final firing readily to reduce the moisture content has led to insufficient precautions being taken to minimize the absorption of moisture after teas have left the drier. Final firing does not cure all ills. It does not for one thing bring back the original properties of a tea all that it does is to check deterioration that has started in a tea. It will be examined further in Chapter 11.

From what has been discussed so far the optimum conditions for firing may be summarized as follows:—

1. A firing temperature of 185-195°F.
2. An exhaust temperature of 120-130°F (in the case of a tilting tray machine 115-135°F).
3. A period of drying of 18 to 21 minutes (24 minutes for big bulk).
4. A moisture content of about 3% in the discharged tea.

After firing, a tea should be cooled quickly with the minimum absorption of moisture.

Precautions after Firing.—The first precaution to be taken is to see that the teas are cooled off quickly. It must be remembered that teas are discharged from a drier at a temperature a few degrees below that of the inlet, and if this heat is retained it is tantamount to extending the period of firing. When teas are stored in a hot condition they acquire a "bakey" character and also lose a little quality.

Teas cannot be cooled, however, without picking up some moisture. The harmful effects of excessive gain in moisture have already been stressed. Since freshly fired teas gain moisture rapidly they should not therefore remain exposed for too long. If spread thinly, they are cooled within a few minutes and when they are just warm to the touch should be packed and stored in covered boxes.

One other precaution necessary when cooling tea is not to expose it in a position subject to draughts. In damp weather, especially, care should be taken to prevent outside air being drawn over the dry tea while it is being cooled. If firing rooms are well ventilated and all the necessary measures adopted, tea during cooling will rarely pick up more than half per cent. of moisture.

Maintenance and Operation of Driers.—Certain rules other than those mentioned so far have to be observed to make a success of the firing process. These are:—

TEA MANUFACTURE IN CEYLON

1. In an endless chain machine the blade of the automatic spreader should touch the feeding trays at the lowest setting.
2. In a raised position the edge of the blade must be at a uniform height above the trays.
3. The time taken by the leaf to pass through the drier must be checked against each step-pulley
4. Trays should be in a perfect condition with no gaps between them.
5. Thermometers must be periodically checked.
6. By-pass valves should be kept closed.
7. 'Fall-through' (addappu dhool) should be collected at half hourly intervals if there is no device for removing it automatically.
8. In a tilting tray type of drier, tray loads must be weighed and trays charged by a clock.
9. The inlet temperature must vary only within plus or minus two degrees. It can be maintained like this by correct stoking. Except in an emergency, malpractices such as opening port holes and adjustments to the fan valve must not be permitted.
10. Higher temperatures or slipping to a slower pulley to correct underfiring are steps to be taken only if a thinner spread has failed to have the desired effect.
11. Internal spreaders must be examined periodically to see that they are actually performing the function they are intended for. They should not be lowered too much to cause banking up of the leaf.
12. Drier trays must be cleaned before the day's work is started, a precaution often generally neglected. At the end of a day's work quite a fair number of the tray perforations will be found blocked with tea. All attached leaf must be removed, otherwise air flow is impeded to some extent.

Stoves and Furnaces—In an indirect heater only a part of the heat is transferred from the fuel to the air used for the drying of tea. Some of it, depending on the thermal efficiency of the stove and skill of operation, escapes up the chimney. The two steps therefore necessary to conserve fuel as much as possible are to have good combustion and to avoid an excessive draught. By careful use of the chimney damper or induced draft fan a considerable saving of fuel can be achieved. Failure to consider their influence on the combustion of a fuel has more often than not given rise to fallacies on the efficiencies of fuels.

Besides the chimney damper, there are other easy forms of control in a stove for regulating the combustion of fuel. The furnace door is one; the door below the grate is another; and in the case of an oil burner there is the atomizing air and the auxiliary air from the air director. But the total amount of air passing through the furnace, whatever fuel is used is controlled by the chimney damper, or induced draft fan,

Whether wood, oil or coal is burned a good test for knowing if the fuel is being used as efficiently as possible is to judge the amount and colour of smoke issuing from the chimney. A black column of smoke is a sure indication of inefficient combustion. Fuel is also wasted by a roaring

FIRING

draught and is shown up by high temperatures at the base of the chimney. A fuel can be considered to give its full value when the flue temperature is not very much higher than 300°F. and only a haze of smoke is visible at the top of the chimney.

Therefore, to obtain the highest thermal efficiency from a fuel it must be burnt completely but not rapidly. This is easily achieved in the case of liquid fuel, but by careful draught control, both wood and coal can be burnt to give comparatively favourable results.

It is outside the scope of this monograph to describe different stove designs. A reference to them will be found in the *Tea Quarterly*. However, assuming that the most appropriate stove is available the following general hints are given to get the best out of a fuel.

Fuels.

(a) *Wood*.—(i) Firebars should be completely covered by the wood, but at the same time must not interrupt the passage of air through them.

(ii) It is preferable always to have the wood cut into small pieces, particularly if it is wet.

(iii) Fuel must be added at regular intervals and in small amounts.

(iv) The furnace door must be always kept closed.

(v) During lighting up have the flue damper and ash pit doors fully open. After a reasonable fire has been built up draught and temperatures must be controlled by either the chimney damper, I.D. fan, or the ash pit doors, or all three.

(vi) Firebars must be periodically cleared of ash and not allowed to accumulate too much of it.

(b) *Coal*.—Most of the foregoing remarks apply to the stoking of coal, the main difference being that a sloping fire bed and a certain amount of secondary air are needed. The points to observe with regard to coal are :—

(i) There should be a thicker bed of fire in the front of the stove tapering to the back end. According to authoritative sources the coal should be at a depth not greater than six inches, sloping off at the back to about four inches.

(ii) Since coal burns in a different manner from wood, secondary air may have to be admitted through the furnace door. It is generally required when a fresh charge of fuel is put in. When a reaction like this is needed on the fuel bed the ash pit doors can be temporarily closed.

(iii) Excessive smoking occurs when the bed is too thick or the firebars are blocked. But the poker must be used with discretion. Just as in the case of wood, it must be used as little as possible. Poor combustion is indicated by the absence of a reflected glow from the fire on the ash bed.

(c) *Oil*.—The first essential is to have a properly designed combustion chamber, and burner that suits the drier. The efficiency of an oil burner depends on efficient atomization, and is reduced by the presence of excess air which lowers the flame temperature. The amount of air used must be in proportion to the amount of fuel passing through the nozzle.

If a burner is larger than is necessary the oil supply has naturally to be reduced, and the air supply proportionately reduced as well. The

TEA MANUFACTURE IN CEYLON

latter is, however, limited by the fact that a certain amount of air is needed for efficient atomization. Excess air has then to be admitted through the air director with a resultant loss in heat.

If a burner is too small the natural tendency is to increase the oil supply. It is not always possible to increase the atomizing air by a corresponding amount, and imperfect combustion results.

Combustion can be said to be perfect when an oil flame is yellow in colour and only a faint haze of light grey smoke is just visible at the top of the chimney. A white flame indicates too much excess of air.

The precautions therefore to be taken in working a burner at its maximum efficiency are:—

1. A much smaller draught than in the case of wood or coal.
2. The minimum amount of atomizing air to prevent the flame from flickering.
3. The air director shut as far as possible before smoke is noticed.

To enhance the advantages that accrue from close attention to the burning of fuels one very important requisite is that the drier fan is not starved of air. There must be plenty of air accessible to the stove. Flue gases must also circulate freely. Any restrictions cause stagnant areas round tubes and may result in condensation of the products of combustion. These attack the tubes and will ultimately lead to their corrosion. When induced fans are used to create better draught conditions there is always the danger of more air being drawn on one side of the heater than on the other. When this occurs it will be found that the inlet temperature of the air entering the drier is not the same on both sides of the machine. Small differences of a few degrees may be ignored, but if the difference is 10° or over the fault must be corrected. This is done by altering the positions of the flue dampers. Once the correct adjustment has been made these should not be interfered with.

Firing Costs—A substantial difference exists in the cost of firing with the three different types of fuel just discussed. The two main reasons are that their calorific values are not the same and their costs are different. Though wood has a much lower calorific value than either coal or oil, it is often the cheapest of the three and therefore obviously the most economical to use.

Since the costs of fuels vary from estate to estate and are never static no useful purpose will be served by discussing actual costs. What perhaps will be useful to know is their relative values.

Roughly speaking, under the same conditions of firing 1 gallon of oil is equivalent to about 20 lb. of coal or 40 lb. of good dry wood. Taking the average weight of a cubic yard of firewood to be about 800 lb. these figures mean that it will be cheaper to use oil if the cost of 20 gallons is less than that of a yard of firewood. Coal will be more economical if a hundredweight of it is available at less than the price of about a quarter of a yard of firewood.

If the comparison is based on a lighter species of wood, weighing say only 400 lb. per yard, then a yard of this firewood would be approximately equivalent to 10 gallons of oil or 2 cwt. of coal.

In terms of pounds of made tea it may be assumed that 1 gallon of oil fires 30 lb., a pound of coal 1½ lb., and a yard of firewood 600 lb.

FIRING

These figures will vary considerably from estate to estate, but they may be used as a basis for working out comparative costs when a change from one fuel to another is contemplated.

The factors that can appreciably alter firing costs are:—

1. Design of the stove and method of stoking.
2. The efficiency of an oil burner.
3. Relationship between size of the stove and capacity of the drier fan.
4. Efficiency of transfer of heat from the tubes to the air.
5. The firing temperature.
6. The degree of wither.
7. The size of the drier.
8. The length of the working day.
9. The temperature of the atmosphere (more heat is required to raise the temperature to a given figure when the outside temperature is say 65°F, than if it were 80°F).

Drier Capacities—The capacity of a drier is generally expressed in terms of the number of pounds of made tea it can turn out per hour. But this is affected by several factors, the more important of which are uneven spreading in an endless chain drier, temperature and wither. The first named factor affects the output when as a result of the edge of a spreader blade not being parallel to the feeding trays the feed of leaf is not even. To the eye the spread of leaf may look perfectly uniform but it can always be easily checked by comparing the weight of tea delivered from one side of the machine with that which comes from the other.

The effect of temperature is more marked, the higher the temperature the greater the output. A drier working at 210°F, for instance, would give a 50% higher output than if it were operated at 190°F.

The degree of wither affects the output of a drier for the simple reason that under fixed conditions of temperature and air flow, a drier is capable of evaporating only a certain amount of water. The amount of moisture that has to be evaporated from leaf must not exceed the evaporative capacity of a drier. It therefore follows that the rate of loading must vary according to the wither, being less for leaf having a high moisture content and more for hard-withered leaf. Hence the output is affected. An idea of the extent to which it varies may be had from table XIX in which four different standard sizes of driers are compared. The figures corresponding to a 45% outturn of made tea to withered leaf are the rated outputs.

Table XIX. *Effect of wither on output of a drier.*

Type of wither	% outturn of made tea to withered leaf	DRIER			
		3'	4'	5'	6'
		Output per hour lb.			
Very soft	40	120	200	280	360
Soft	42	132	220	308	396
Medium	45	150	250	350	450
Hard	48	168	280	392	504
Very hard	50	180	280	420	540

TEA MANUFACTURE IN CEYLON

These figures are convincing enough to show how careful one must be in drawing conclusions from drier performances.

One other factor that has a marked effect on drier output is the 'blow-out', which will be a considerable proportion of the weight of made tea if the speed of air through the drier is excessive. More often than not an unduly high outturn of 'blow-out' is caused by flaky leaf lacking the necessary weight to remain in the stream of air.

To conclude this chapter on firing it only remains to draw attention once again to the importance of having the correct moisture in the fired tea. It is true that some idea of the correctness of firing can be obtained by the feel and smell of the tea or by breaking a particle and examining it. But these are not infallible tests. Apparatus for determining moisture contents are available and no factory should be without one.

CHAPTER 10

GRADING

Grading is a very important process in tea manufacture, and the way it is carried out may make all the difference to the value of a tea. The separating of the tea particles into various shapes and sizes conforming to trade requirements involves many operations. Machine sifting alone is not enough; hand sieves have to be used as well, in addition to which the grades have to be winnowed and picked. The whole procedure is a long and tedious one, becoming laborious when a large number grades are made. On account of variations of leaf and of methods of manufacture, it varies considerably in different factories.

Not being a regular series of operations it is the one process in manufacture for which no hard and fast rule can be laid down. Careful judgement is required to decide whether a grade has to be re-sifted or not; whether or not a grade is true to type; whether it is sufficiently uniform or free from reds to pass muster. Such considerations necessitate a considerable amount of skill, care and attention. A sifting procedure that may suit one estate may therefore prove unsuccessful in another. However, the following description may form the general lines on which the grading process can proceed.

Sifting Procedure—The two popular types of made-tea sifters in Ceylon tea factories are the 'Michie' which works on the oscillatory principle and the 'Moore' in which the motion is rotary. They differ not only in their action but also in the number of trays. The 'Michie,' as a rule, is provided with 2 trays, whereas the 'Moore' has 5 trays. The size of mesh varies to suit different requirements but is more usually of the following order:—

- (A) Michie —Top tray No. 10
Bottom tray No. 24
(B) Moore —Nos. 8, 10, 12, 14 and 24.

These two sifters are sometimes used singly or supplementary to each other depending on the crop handled and on the type of tea required.

(A) *Michie Sifter*:—

(i) *The early dhools*.—The leaf that goes over No. 10 is picked, cut and sifted. The fraction that comes over No. 10, if not of uniform size, may have to be cut again and re-sifted. The final fraction is flowery pekoe (F.P.).

The fraction through No. 10 and above No. 24 usually contains small size particles, which have to be sifted out by the use of No. 14 or No. 16 or No. 18 mesh. What comes over this small mesh is broken orange pekoe (B.O.P.), and what comes through is broken orange pekoe fannings (B.O.P.F.).

The leaf that has passed through the bottom tray is a mixture of B.O.P.F. and dust, and these two grades are separated by a No. 24 or No. 30 mesh.

If a flowery broken orange pekoe (F.B.O.P.) has to be made, as in the low-country, it is preferable to sift each dhool separately, proceeding as above, but putting the fraction that comes over the top tray over and over again till the maximum amount of wiry leaf is extracted. A Part of this is orange pekoe (O.P.); the leaf that is not long enough for an O.P. grade is F.B.O.P., and the rest, B.O.P. The smallest particles go to make the flowery broken orange pekoe fannings grade (F.B.O.P.).

TEA MANUFACTURE IN CEYLON

(ii) *The later dhools* (or last dhool).—It is sometimes advisable to first winnow this, especially if it contains an excessive amount of fibre. The procedure is more or less as for the early dhools, the only difference being that the fraction that goes through No. 10 after the leaf is cut is not amalgamated with the B.O.P grade. Its qualification for inclusion is its appearance. If not stalky it is usually kept separate and classed as a broken pekoe (B.P.)

(iii) *Big bulk*.—This is always first winnowed and picked before sifting. The leaf through No. 10 is B.O.P. The coarser fraction is then cut two or more times till its size is reduced to that of a dhool. It is then treated like the last dhool, but if the fractions through and above No. 10 are not uniform a further cut is given. The fraction through No. 10 is B.P. and that over, pekoe (P.).

The leaf below the bottom tray is too brown to be included in the good fannings dust grades and is classed as broken pekoe fannings (B.P.F.) and dust No. 2

If an orange pekoe (O.P.) grade is required the big bulk is passed a number of times over the tray till no more wiry leaf remains in the fraction that goes over. The wiry leaf is then separated from what has gone through the No. 10 mesh by the use of a bamboo or stamped aluminium hand sieve. For the final operation brass weave is not suitable, the reason being that a smaller effective sifting area can be obtained, without reducing the size of the aperture, from the other two types. If brass weave with the same size of holes is used the separation of the thin wiry leaf from the loosely twisted leaf is difficult. What finally remains over the sieve is the orange pekoe grade. The remaining leaf is cut, from which B.P., pekoe, B.P.F. and dust No. 2 are made.

(B) *Moore sifter*.—Because of the greater number of trays in this machine than in the 'Michie' a part of the B.O.P. and a part of the B.O.P.F. is separated in the first operation. The rules which apply for the treatment of the dhools when using the Michie hold good for the Moore as well, but since 6 fractions are obtained instead of 3 the procedure has naturally to be different. For easy description the fractions are referred to as follows:—

Fraction (1) over	No. 8		
„ (2) through	No. 8 and over	No. 10	
„ (3) „	No. 10 and „	No. 12	
„ (4) „	No. 12 and „	No. 14	
„ (5) „	No. 14 and „	No. 24	
„ (6) „	No. 24.		

(i) *The early dhools*:—

(a) FIRST OPERATION:—

- Fraction (1)—cut
- „ (2)—resifted or cut according to size obtained.
- „ (3)—B.O.P.
- „ (4)—B.O.P.
- „ (5)—B.O.P.F.
- „ (6)—Dust

(b) SECOND OPERATION (cut tea re-sifted):—

- „ (1)—F.P.
- „ (2)—F.P. + B.O.P.
- „ (3)—B.O.P.
- „ (4)—B.O.P.
- „ (5)—B.O.P.F.
- „ (6)—Dust

(c) Another operation may be found necessary if fraction (5) from operations (a) and (b) is too large for a fannings grade.

GRADING

(ii) *The later dhools* (or last dhool);—

(d) FIRST OPERATION:—

Fraction (1)—Cut
 „ (2)—Cut
 „ (3)—B.O.P.
 „ (4)—B.O.P.
 „ (5)—B.O.P.F.
 „ (6)—Dust.

(e) SECOND OPERATION (cut tea re-sifted):—

Fraction (1)—F.P. or Pekoe
 „ (2)—F.P. + B.P. (or B.O.P.)
 „ (3)—B.P. (or B.O.P.)
 „ (4)—B.P. (or B.O.P.)
 „ (5)—B.O.P.F.
 „ (6)—Dust

(f) as for (c) in early dhools.

(iii) *Big bulk*:—Owing to the horizontal rotary motion of this type of sifter the separation of the O.P. grade is not feasible.

(g) FIRST OPERATION:—Fraction (1) has therefore got to be sifted in the Michie or similar type of sorter when O.P. is required and treated as previously described.

Fraction (2)—if wiry, may be similarly treated, otherwise this and fraction (1) are cut when the O.P. grade is not made.

Fraction (3)—B.O.P.
 „ (4)—B.O.P.
 „ (5)—B.O.P.F.
 „ (6)—Dust

(h) SECOND OPERATION:—(cut tea re-sifted)

Fraction (1)—Pekoe
 „ (2)—B.P.
 „ (3)—B.P.
 „ (4)—B.P.
 „ (5)—B.P.F.
 „ (6)—Dust No. 2.

All grades are then winnowed, the browner and lighter separations going to form the 'off-grades' such as broken mixed, and inferior fannings and dusts. Finally they are picked.

For a normal standard of plucking and assuming the leaf has been rolled 4 times, true grades should be obtained from the following sources:—

<i>Grade</i>	<i>Source</i>
B.O.P.	Dhools 1. 2. 3. (cut leaf included)
	„ 4 (uncut leaf only)
	B.B. („ „ „ „)
B.P.	Dhool 4 (cut leaf)
	B.B. („ „)
B.O.P.F.	as for B.O.P.
B.P.F.	as for B.P.
Dust No. 1	as for B.O.P.
„ No. 2	as for B.P.
F.B.O.P.	Dhools 1 and 2 (uncut leaf)
F.B.O.P.F.	„ 1 and 2 (cut leaf)
F.P.	„ 1. 2. 3. 4.
Pekoe	B.B.
O.P.	B.B. and Dhool 1.
Broken mixed	all dhools and B.B.

TEA MANUFACTURE IN CEYLON

One general rule in sifting is to treat each dhool on its own merits, conserving any special features that it may have. Mixing of dhools before sifting must be governed by the amount of tip or 'reds' they possess. In low-country tea, particularly, the standard of appearance of which must be relatively high it is advisable to sift each dhool separately. Stalky dhools must be picked before cutting, whenever possible to facilitate the picking operation. Big bulk should as a rule be first winnowed and picked in any case before it is sorted. The other main principle to be followed in grading is the taking out of true grades, considering not only the appearance but the size and liquoring properties as well, because it is all these features which go to make any particular grade. The practice of merely chopping up teas to produce grades such as B.O.P. and B.O.P. fannings, for instance, only result in a marked lowering of the general standard. Good grades cannot be specified by mesh alone. They must strictly conform to their trade names.

Description of Grades—It is not possible to give a strict definition of any grade because no fundamental standards now exist. Even the names originally given to grades no longer bear any relationship to what they represent to-day. For example 'flowery pekoe' was first used to describe the tea from buds and very immature leaves and was derived from the Chinese words "Pek Oh" which signified the white down they possessed. To-day the term 'flowery pekoe' may describe any sort of knobby tea. 'Fannings' as its name indicates was that fraction of a tea separated by fanning (winnowing). In the modern sense the word refers to a grade that is little larger than dust.

In recent years owing to the increasing tendency to prefer liquors to appearance there has been a relaxation in the definition of various terms. A typical example is the B.O.P. grade. Some section of the trade are prepared to accept an amalgamation of a B.O.P. and fannings as a B.O.P. grade. If the B.O.P. happens to be small and neat, the mixture may very well pass for a fannings grade. Even the so-called flowery pekoe may be nothing but an ordinary pekoe.

The lack of uniformity of the present day market grades makes it therefore difficult to describe these with any accuracy. However, since nomenclature does influence to a great extent the value of a tea, it may be useful to give a rough description of the regular grades current in Ceylon to-day. The glossary given below describes the generally accepted standards.

Broken Orange Pekoe (B.O.P.)—A true natural B.O.P. should consist of only that leaf broken up in the rollers which passes through a No. 10 mesh, but not through No. 18. It forms about 50% of the crop. But to-day a 60% to 70% outturn of this grade is not unusual, the increased outturn being obtained by adding tea cut up from coarser leaf. Some estates make as much as 80% of this grade, by the addition of fannings. The admixture of different grades diminishes the quality and appearance, but when either of these two characteristics is much in evidence the value of the resultant product is not appreciably lowered.

Since the sale of a B.O.P. grade depends on both its appearance and liquoring properties the greatest care should be taken to avoid spoiling it by adding too much of tea with a poor appearance or poor quality, particularly cut stalk. It may, however, contain cut leaf. A fair outturn is 60%.

Flowery Broken Orange Pekoe (F.B.O.P.)—This is usually derived from the early dhools, and must contain a reasonable amount of tip. The particles are longer than an average B.O.P. and must have a well twisted appearance. A satisfactory outturn is about 10%. This grade is marketed more for its appearance than liquor.

GRADING

Orange Pekoe (O.P.)—This is another fancy grade like F.B.O.P. and comes chiefly from the big bulk. It contains no tip and is thin and light in liquor. It is slightly longer than F.B.O.P. and must be better twisted and more wiry. It consists of very tightly rolled leaf and mostly long tender stalk.

The percentage depends on the B.B. outturn and may be as high as 10% or more.

Broken Pekoe (B.P.)—This grade is of about the same size as B.O.P. sometimes slightly larger, and is easily recognizable by the cut ends of the particles. It is not so black as the average B.O.P. grade, has no tip and consist chiefly of cut stalk. It is derived from the last dhool and big bulk and has therefore very poor liquoring properties.

Its normal outturn is about 5%.

Flowery Pekoe (F.P.)—Leaf that is too large to pass through No. 10 mesh is given the name F.P., but it must be even, curly and free from stalk and flake. It consist of leaf that is well twisted and has a somewhat shotty appearance. Its outturn is mainly influenced by the size of the roll-breaker mesh employed. If true to type it should not be more than 1%. Its liquor, through light, must compare favourably in quality with that of the B.O.P. grade.

Pekoe (P)—It is the largest of the leafy grades and in the true sense should be entirely shotty in character. It is derived from sappy well withered leaf which rolls into 'balls' and can be found in all the dhools and big bulk. If true to type the outturn is very small, not being more than 1%. Like all leafy grades its liquor is inferior to B.O.P. and it sells mainly for its appearance. The Pekoe, nowadays, is inclined to contain a considerable quantity of 'cut leaf' and may be slightly open.

The present trends are to combine the F.P. and pekoe grades calling the mixture F.P. if the teas are from up country, and pekoe in the case of low-country teas,

Broken Orange Pekoe Fannings (B.O.P.F.)—This a small sized grade taken through No. 14, or No. 16 or No. 18 mesh according to market demands. It should be derived from the finer leaf and be black in appearance. It is grainy when separated by a smaller mesh and leafy when it is larger in size. It may also be flaky, irrespective of size, as a result of poor leaf or faulty manufacture.

Its outturn is influenced by the method of rolling and can be regulated by the percentage of B.O.P. taken out. Generally speaking, the outturns of B.O.P. and B.O.P.F. add up to about 70%. That is to say, if the B.O.P. percentage is 60%, that of B.O.P.F. can be expected to be about 10%. If the former is 40% the latter would be about 30%. But the character of the grades in the two cases would be entirely different.

Owing to its rapid brewing properties a fannings grade gives strong, coloury liquors.

Flowery Broken Orange Pekoe Fannings (F.B.O.P.F.)—It is that part of a B.O.P.F. with an abnormal amount of tip and as it can only be derived from early dhools, does not exceed 10% in outturn.

Broken Pekoe Fannings (B.P.F.)—This grade is generally of about the same size as B.O.P.F. but very much inferior in appearance. It is present in the later dhools and produced when leaf is cut. It is brownish in colour and very flaky. Its outturn depends on the standard of appearance required of the B.O.P.F.

TEA MANUFACTURE IN CEYLON

Dust (D.)—This is the smallest of the grades and is so small as to resemble actual dust. Its value is chiefly influenced by its appearance. A good dust should be grainy, very black and free from fibre and grit. Its appearance is improved by winnowing, the browner fractions being classed as dust No. 2 and dust No. 3.

Inferior dusts are also produced by crushing coarse leaf. If abnormal methods are not employed the outturn of the dust grade is small and as low as 3%. It gives a thick, strong liquoring tea.

Broken Mixed (B.M.)—This grade, as its name implies, is a mixture of the flaky tea obtained from the winnowing of the regular grades. It has no fixed size, is uneven and consists of flat leaf and stalk. The liquor lacks quality, but has fair strength and colour. When pulverized to dust, its liquoring properties are improved.

The percentage outturn of B.M. reflects the standard of plucking. Coarse leaf may bring it up to 20%, whilst fine standards of plucking may produce only an insignificant amount. High broken mixed outturns can also be caused by under-withered leaf, insufficient rolling, or too severe fittings on roller tables. Under normal conditions it is about 5%.

Waste Tea—This is not a grade tea in the real sense of the word, but since its outturn is of considerable importance a reference to it is not irrelevant. If grading is done on methodical lines and leaf is of an average standard the percentage of refuse tea need not be higher than 3%.

Waste tea usually contains some broken mixed and dust. If these are eliminated, actual refuse, made up of fluff, fibre and pickings, is unlikely to amount to more than 1% of the crop. These figures will vary according to the standard of plucking.

Character of Grades—This is effected by various factors, one of which is the standard of plucking. Coarse leaf introduces 'reds' caused by the stripping of mature stalk and centre ribs of leaves, which are hard to eliminate. Flaky tea is another contribution. Altitude and jat also have an important bearing on the style and colour of teas. The sappy, high jat found at lower elevations produce blacker and better twisted teas than those turned out from the tougher varieties in the up-country districts.

Withering is a factor to be taken into account. Over-withered leaf does not twist in the rollers and breaks up readily. Flaky tea is again obtained from under-withered leaf. The colour of the tip is also affected by the degree of wither.

The influence of rolling is in the main connected with the size of the grades and their outturns. Heavy pressure in conjunction with small roll-breaker mesh results in smaller types. Light rolling produces a greater proportion of large leafy grades. The two types of tea are easily distinguishable.

The method of sorting, as it affects outturns, can alter the character of a tea to a marked extent. For instance, the amalgamation of grades such as B.O.P. with B.P., B.O.P. with fannings, F.P. with pekoe or, B.O.P.F. with P.F. makes a vast difference not only to the general appearance of a grade, but its liquoring properties as well. It is a debatable point whether it is worthwhile to make less of one grade and more of another. Quite often the increase in the outturn of a grade is accomplished at the expense of itself and the improvement of another. The only criterion, as to which procedure is more profitable, is the average price obtained for all the grades.

GRADING

This is a point likely to be overlooked in the desire to increase the outturn of two particular grades, namely, O.P. and B.O.P.F., which in recent years have been in great demand. Thus by focussing too much attention on O.P. the rolling operation may in fact, be shortened to the detriment of other grades. Unduly high big bulk outturns are taken, the greater proportion of which consist of under-rolled, loosely twisted and flaky leaf. In the case of the B.O.P.F. grade the other extreme of over-rolling may be obtained in an attempt to get an excessive outturn. As the price difference between this grade and the B.O.P. increases, the temptation to make more fannings also increases, and still harder rolling is employed, usually achieved by double roll-breaking of the dhool through a small mesh. This treatment may ultimately result in the B.O.P. grade being badly broken up with a resultant loss in appearance and in liquoring properties as well, on account of the finer leaf going into the fannings grade. Arising from this the B.O.P. grade is valued still lower than the B.O.P.F. The conclusion is then drawn that it pays to make only a fannings grade, an inference which may lead to a false sense of values.

The practice of grading to certain pre-determined outturns may create a similar situation. It may impose a set of conditions that in actual practice is unworkable if true grades are to be obtained. For example, when an estate is confronted with the task of turning out a high percentage of fannings, the outturn may be increased by cutting. This affects the appearance of all grades. The problem becomes more acute if the outturn of broken mixed and waste tea is limited to a ridiculously low figure that can only be associated with a good standard of leaf. If plucking is coarse, the appearance of every grade, bad as it already is on account of stalk, fibre and open leaf, will then have to be sacrificed in order to keep the outturn of off grades as low as possible. All grades thus become diluted with teas that should normally go as broken tea, fannings No. 2, dust No. 2, and B.P. No. 2.

The number of grades that are taken out also affect their general character. The greater the sub-division, the more true to type they are. In small factories owing to the time taken to collect sufficient amounts of certain grades for a break the number of grades is limited. It will necessitate the inclusion of some grades with others and thus change their characteristics.

The last, but by no means least important factor, which contributes to the style of a tea, is the sieve.

Sieves—Tea sieves are of three kinds:—bamboo, wire mesh and stamped aluminium. The first named, on account of its fragile nature, is not used in mechanical sifters, but as a hand sieve for separating the O.P. grade generally. The extraction of this particular grade requires a great deal of manipulation. The bamboo sieve on accounts of its lightness serves the purpose admirably. It is, however, not suitable for small sized grades because the width of the cane reduces the effective sifting area considerably.

The sifting area of a sieve is governed not only by the size of the holes, but the thickness of the divisions between them. Stamped aluminium for example, on account of its thicker divisions than brass weave will therefore, for the same size of holes have a less number of them per unit area. The effective sifting area will thus be different in the two cases. It is not possible to compensate for such differences by altering the rate of feed only. However much may be done in this direction the composition of the grades will not be the same. To get equivalent results larger holes in stamped aluminium sheets are necessary. Even

TEA MANUFACTURE IN CEYLON

then, care must be taken in controlling the rate of feed. If too slow, the tea that passes through will be uneven ; if too fast, a part of the grade that is required will pass over.

When comparing stamped aluminium with brass weave it is most important to remember these points. For a grade sorted out from the former to approximate very closely that from the latter the width of the holes must not be the same. Two other important considerations are the number of holes per unit area and the shade of the perforation in an aluminium sheet. A square hole of the same width as a circular hole has a much bigger aperture.

Because of their comparative smoothness, which tends to reduce the scratching of the surface of tea particles, stamped aluminium sieves are gaining in popularity. It is necessary therefore to know how their sieving performance compares with that of the ordinary brass weave. Unlike wire mesh which is numbered according to the holes per linear inch, and the size of each in millimetres. The perforations may be either square or round. Table XX gives the equivalents of stamped aluminium to brass weave at about the same rate of feed.

Table XX. *Equivalent of stamped aluminium to brass weave.*

SQUARE PERFORATIONS		CIRCULAR PERFORATIONS		Closest corresponding brass mesh
Size in mm.	No. per sq. inch	Size in mm.	No. per sq inch	
1	196	1	135	No. 18-16
1½	100	2	78	No. 14
2	49	2½	52	No. 12
2½	39	3	37	No. 10
3	25	3½	31	No. 8

If oversize perforations have to be used, they should be counter-balanced by a faster rate of feed. The weight of sievings obtained will then be approximately the same as that given by brass mesh but the grades will not be as even.

Whatever type of sieve is used, over-feeding of a sifter with a view to hastening the process should always be avoided. As in the case of roll-breaking a made tea sifter should be carefully adjusted in relation to speed, slope of tray and size of mesh to give best results.

The value of a grade is often judged by its uniformity, but in attaining this objective sifting may be overdone. Careful and judicious use of sieves is necessary to decide how perfect a grade is before excessive rubbing actions ruins its appearance by greying.

Greying of Tea—Greyness of tea is the result of the dried coating of juice on tea being rubbed off. Most of the fluff found in a tea factory comes from this source. The presence of fluff in a factory is therefore an indication of excessive handling and rubbing of the tea. In view of the fact that these actions not only grey the tea and spoil its appearance, but also result in loss of some soluble matter, all possible precautions must be taken to minimize the abrasion tea has to be subject to after it leaves the drier. These are enumerated below:—

1. It is always preferable to sift tea after it has been kept at least a few hours. Hot tea is very brittle and in this condition the slightest

GRADING

rubbing of the surface tends to cause greyness. After a tea has absorbed a little moisture the surface is less apt to become scratched.

2. Unless it is absolutely necessary tea should not be rubbed over the mesh of a sieve. When hand sieves are employed the minimum amount of tea should be shaken at a time.

3. Sagging sieves must not be used.

4. Cutters should be in perfect order. Knives should be absolutely flush with the rolls and re-ground or adjusted whenever the smallest gap is noticed. The size of the cells must bear some relationship to the size of the dhool. If it is much larger than the size of the tea particles which are treated, little effective action takes place, and the teas are unnecessarily rubbed. Too small a cell results in the tea being subject to a churning effect for a longer period. The absence of a hopper considerably increases greying in a similar manner and so does a blunt knife. Repeated cutting will result in flakiness.

5. As far as practicable, it is best to avoid cutting a tea repeatedly. It may be found worthwhile when a tea requires more than one cut to sift it after the first treatment before it is cut again. Big bulk is the only exception.

6. Excessive use of a cutter is an indication of unsuitable roll-breaker mesh. Much can be done in the rolling stage of manufacture to reduce the greying effect caused by sifting and cutting.

7. Final firing or passing tea through a drier prior to packing is another cause of greying. A second winnowing of the tea should not be necessary if it has been done properly in the first case.

Winnowing of Tea—The separation of extraneous matter, fluff and fibre can either be done by an air blast, or in a gentle stream of air. The machine employing the former principle is a blower, and the latter, which works on the principle of suction is called a winnower. In either case the tea is cleaned extremely well, but compared to the blower the winnowing machine has certain definite advantages. There is a saving in time and the extraction of foreign matter is more easily carried out.

The modern winnower is so constructed that the speed of air varies throughout its length, being greatest at the point where the tea falls from the hopper. In this way an almost perfectly clean separation is brought about between stones, gravel, heavier tea, lighter tea, flake, fibre and fluff. Boxes situated beneath the air stream enable the various fractions to be collected. The air flow is adjustable, which is another important advantage in favour of the winnower since grades vary in density.

The blower, on the other hand, is not capable of offering these advantages. Undesirable leaf may get mixed with good tea and more operations are needed to clean it. Regulation of the speed of air is also difficult.

Stalks are not removed by winnowing since they are of about the same weight as tea and it is very doubtful whether any improvements in pneumatic methods are possible.

Stalk Extraction—The elimination of stalk from tea still remains a serious problem, and is of such concern that various machines are put on the market from time to time for ridding the tea of this undesirable feature. Recently, two methods have shown much promise. In one a 'breaker' is used in conjunction with the Myddleton Stalk Extractor, which results in the stalk and tea being broken up into different sizes, thus facilitating the extraction of stalk. In the other method, separation is brought about by the employment of a strong electrostatic force, which

TEA MANUFACTURE IN CEYLON

induces different charges on stalk and tea particles on account of the difference in their surface conductivity.

Though these machines serve a very useful purpose in reducing picking cost, they can by indiscriminate use affect adversely the liquoring properties of a tea. In the case of a breaker the greatest care should be taken not only in the selection of the material to be treated but also in the regulation of pressure and the thickness of spread. A breaker should not be used with the intention of increasing the outturn of the B.O.P.F. grade or in place of a cutter for the larger leaf in the earlier dhools. The electrostatic stalk extractor does no damage to the leaf but in endeavouring to remove heavy stalk there is the danger of removing good tea with it.

Both type of machines have therefore a limited application and are complementary to each other, since the electrostatic extractor can only separate light stalk whilst the breaker is more suitable for the heavier stalk. However, too much dependence should not be placed on such machines and whenever the circumstances warrant it recourse to hand picking is advisable.

The extraction of stalk by hand can be aided by a device employing the suction principle. This is the Benville Red Leaf Picker. Compared with hand picking, cost is about the same, but the appearance of the tea is better. For good standards of leaf the difference in appearance is not so marked as to affect prices, but the Benville Picker should be more advantageous when dealing with leaf containing a high proportion of 'reds'. For low-country teas, the value of which is to a great extent influenced by appearance, it will be found particularly useful. The only disadvantage the Benville Picker possesses is that it is not capable of dealing with big bulk and long wiry leaf.

A further aid to better picking is the use of glass topped tables, the surface under the glass being painted black. This shows up the red stalk very clearly and on account of the smoother surface reduces greying of the tea as well.

Moisture Absorption during Sifting and Picking—The absorption of moisture by tea during these operations is inevitable, but care should be taken to prevent an excessive gain.

One of the first precautions is to maintain the sifting room in a reasonably dry condition. In wet weather this may be difficult, but the best use should always be made of heated air from the driers. It is not necessary that they should be specially lit up for this purpose, but when they are being used for the firing of tea, the exhaust air must always be drawn into the sifting room if the outside air happens to be humid.

Though the air exhausted from a drier contains the moisture evaporated from the wet leaf in the machine, its relative humidity is lower than that of the atmosphere. The point to be noted here is that the rate of absorption of moisture by tea is governed not by the amount of water present in the air, but by its percentage relative humidity. Therefore, if teas are to take up the minimum amount of moisture, the relative humidity of the air should be as low as possible. If it is too low, teas will loose moisture and this is not desirable either. Conditions are ideal when tea does not loose or pick up moisture and these exist when the relative humidity is 60 to 65 per cent.

In practice it is not possible to maintain the air in a grading room at the correct degree of humidity, but it is not difficult by a manipulation

GRADING

of doors and windows and drawing in of warm air to create suitable conditions. The moisture content of tea can be kept fairly stable if a difference of not less than 6°F between wet and dry bulb temperature is maintained.

A hygrometer in a grading room is therefore most essential, but unfortunately few factories attach any importance to one, and those that do possess such an instrument seldom or never take advantage of it to provide the conditions suitable for the exposure of tea.

Considering that tea absorbs further moisture during storage and transit and that its keeping qualities are related to its moisture content, no efforts should be spared to minimize the gain in moisture. Because a tea may be well fired and discharged from a drier at the correct moisture content, there is no justification for complacency. The following measures are recommended for the prevention of excessive gain of moisture:—

1. Hot teas have a stronger attraction for moisture. Teas should therefore be cooled before they are sifted.
2. Teas stored overnight should be packed in covered boxes.
3. Teas should be sifted daily.
4. Teas must not be exposed longer than is necessary.
5. In wet weather, the grading and picking operations may be delayed till warm air is available from the driers.
6. Sifting room windows should not be left open on damp days.
7. When the draught created by a dust fan is used for winnowing, precautions should be taken to see that humid air is not drawn in. This applies to winnowers and blowers as well. It is always advisable to hold up winnowing pending the lighting up of the driers.
8. On bright, sunny days a few windows in the grading room must be kept open and the entry of hot air from the sifting room prevented.
9. Teas which have been picked over should not be left lying about. They should be stored in boxes.
10. A sifting room should be damp-proof and have a ceiling.
11. Dust fans should be covered at the end of the day's work, to prevent ingress of damp night air into the sifting room.

If these precautions are taken the total gain in moisture from the time tea is discharged from the drier to the time it is ready to be put into the bins is unlikely to exceed 1%, but some grades may have more moisture than others. This is not due to different grades having different hygroscopic properties; there is evidence to suggest that leafy grades absorb moisture at the same rate as broken grades. The explanation probably is that the stalky portions of leaf leave a drier at a higher moisture content and are also exposed to the atmosphere for a longer period because of the longer time taken to pick over stalky grades. Off grades which generally are left lying about the floor the whole day long will naturally take up the most moisture. These variations are shown in Table XXI, the figures in which represent a day's make sifted at St. Coombs factory under conditions likely to be experienced in any up-country factory.

TEA MANUFACTURE IN CEYLON

Table XXI. *Gain in moisture during sifting and picking*

PERCENTAGE MOISTURE CONTENT			
Fired teas		Sifted teas	
All dhools	2.7	B.O.P.	3.5
Big bulk	4.0	F.P.	4.4
Adappu dhool	3.5	B.O.P.F.	3.8
Blow-out (refired)	2.5	B.P.	5.3
		Pekoe	5.5
		Dust	4.0
		Broken mixed	5.7
		Pekoe fannings	4.9
		Pickings	5.7

Note:—Total increase in weight of all the teas sifted approximately 1%.

The gain in weight of a tea as a result of moisture absorption, is a question of considerable importance. In the example just quoted, waste tea inclusive of pickings amounted to about 2% of the days make. If these are not included the *total weight of grades* will actually be 1% less than the total weight of unsifted of teas. Had the overall gain in moisture been 2% no excess in the *weight of grades* would have been recorded.

The percentage of refuse tea is not the only consideration when examining this question. If the blow-out from a drier is not recorded but included with the sifted teas a false increase will be registered. Deceptive increases will also be noted if the practice is permitted of making arbitrary deductions in the weight of the fired tea to cover up possible losses during sifting. It may not be realized that the blow-out from a drier contains some inferior broken mixed which finds its way into the crop. When refired, and the fibre, etc. discarded, the off grades obtainable from it may be as much as 2%. If this is originally not accounted for, but included in the crop most misleading inferences may be drawn.

The following examples are given to show how the inclusion or exclusion of blow-out and refuse tea alters sifting losses and increases. Assume 2% refired blow-out (free of fibre, etc.), 2% refuse tea and a 1% increase in weight after sifting. If the total weight of fired tea inclusive of big bulk and adappu dhool is say 1,000 lb. the weights will be more or less as follows:—

Before sifting:—

Weight of dhools, etc.	1,000 lb.
Weight of blow-out	20 lb.
Total	<u>1,020 lb.</u>

After sifting:—

(1% increase and, therefore a total weight of 1,020 lb. plus 1% of 0,020 = 1.030 lb.):

Weight of grades	1,010 lb.
Weight of refuse	20 lb.
Total	<u>1,030 lb.</u>

If the blow-out has not been recorded, but included with the crop, the increase in weight of the grades will be 1.010—1,000 lb.=10 lb. which is 1% whereas if it has been taken into account there is no increase but an actual loss of 1% (1,020 — 1,010).

GRADING

If the weight of refuse tea is included, the first example will show an increase of 30 lb. or 3%, and the second an increase of only 10 lb. or 1%

If the gain in sifting is 2% and not 1% the total weight of the grades will be approximately that of the dhools, etc. and blow-out.

Allowing for losses in sifting, therefore, it can be expected that on the average the grades would add up to 100% or less of the unsifted tea (blow out included). Should an increase be noted it could be concluded that the teas have taken up more moisture than is good for them and that an improvement in sifting room conditions is necessary.

CHAPTER 11

STORAGE AND PACKING

It is necessary to recapitulate what has been discussed in the previous two chapters on the moisture content of tea to understand its relation to quality and keeping properties.

The three important points to note are, first that when tea is fired the ferments are inactivated and the moisture content reduced. The second is that tea being a hygroscopic material loses, or takes up moisture, according to atmospheric humidity. And the third point is that there is a linear relation between moisture content and keeping properties.

The question that may well be asked is, what is the connection between the moisture content of made tea and storage? Since tea cannot be completely dried out without a serious detrimental effect on quality oxidation cannot be completely inhibited. A process similar to fermentation therefore takes place after a tea has been fired. The change that is brought about by this post-fermentation accounts for the maturing of a tea.

It may therefore be expected that if a tea is kept too long it will over-mature and ultimately 'fade out.' The oxidation, however is very slow at low moisture contents and teas are known to have kept remarkably well after long periods of storage in air-tight containers. If the moisture content of the tea is too high, it deteriorates rapidly. Since teas have to be stored a considerable length of time before they reach the consumer, it is clear that the moisture content of tea is an important factor in its keeping quality.

The first condition, therefore, which has to be satisfied to preserve a tea is to fire it properly. The moisture content alone does not necessarily indicate whether or not the firing operation has been correctly done. If teas are submitted to too high a temperature in the initial stage of drying, they are case-hardened and the imprisoned moisture in the core renders such teas liable to deterioration. The fault cannot be corrected by a higher firing temperature, it may only make it worse. The load on the drier should be adjusted to give the optimum exhaust temperature of 120 to 130° F.

The next condition is that the tea must be fired to the lowest possible moisture content without impairing its quality. This has been found to be about 3%. It must not be imagined that teas associated with this moisture content will keep indefinitely. The point to note is that such teas can be preserved for a longer duration than teas with a higher moisture content.

It must also be remembered that tea picks up moisture during the grading and picking over operations and again in the bins before it is packed. During this long period of exposure from the time it is fired it may gain as much as 2% moisture or even more, if conditions are unsatisfactory. At the time of packing it may indeed have a moisture content of 5% or over. Even this small rise in moisture content causes definite deterioration, which becomes more rapid when this level is exceeded. This emphasizes the necessity to fire to a reasonable moisture content and to guard against excessive gains in moisture after teas have left the drier.

STORAGE AND PACKING

The safe limit for moisture content is 6 per cent, but before this dangerous figure is reached a tea must be final fired to check deterioration. It is advisable to final fire a tea when the moisture content goes over 5 per cent, to reduce the risk of its 'going off' during transit in the event of packing being faulty. Nothing is gained however by final firing a tea containing less moisture.

The unfavourable effect of a high moisture content necessitates its determination as a routine every time prior to packing. In the case of a grade that has to be stored for an unduly long period, its moisture content should be checked now and again. If this precaution is taken deterioration can be arrested in time by final firing.

Final Firing—This is a second treatment with hot air and all that it does is to check deterioration that has started in a tea. It cannot, and does not, improve the quality of a tea, although it may reduce the dullness of an infusion resulting from storage at a higher moisture content. Its effect is to improve the keeping properties that otherwise would be impaired had the excess moisture not been driven off. In other words, it enables a tea to be stored longer.

Final firing as a regular practice has nothing in its favour, because it results in a loss of quality. It does not appear to be sufficiently realized that when a tea is final fired even at a low temperature the tea is virtually being fired longer than is necessary, and it has already been explained that long firing periods are detrimental to quality. Final firing should therefore only be resorted to as a corrective measure.

For final firing to be effective the moisture content of the tea must be reduced to at least 4 per cent. The temperature employed need not be high. Moderate temperature from 140 to 160°F will be found quite adequate. Higher temperatures cannot be recommended because of their harmful effect on quality. For this range of temperature a period of 12 to 15 minutes will suffice to remove whatever excess moisture is required. But the effect will be negligible if the drier is overloaded. The rate of feeding should be adjusted just as in the firing of wet leaf, according to the exhaust temperature. There should be a drop of at least 20°F in the passage of air through the drier to have an appreciable effect. In any case the moisture content should be checked.

As the teas leave the firing machine they should be bulked and cooled off. Packing them hot may result in a further loss of quality but it will not matter if they are slightly warm at the time they are packed in the chests.

In factories that do not possess moisture determination sets no means is available of deciding whether final firing is necessary or not. Packing teas during prolonged wet weather without knowledge of their moisture contents is a risky undertaking.

Final firing, especially of grades stored longer than a week, will in such circumstances be eminently desirable.

Storage of tea—The gain in moisture content during storage in the bins is very small if they are properly constructed, and situated in a dry position. Having regard to the marked tendency tea has to absorb moisture and the resultant effect it is unnecessary to stress the importance of providing the best possible storage facilities. Any extra expenditure incurred on making a bin air-tight will be fully repaid.

The capacity of the bin in relation to the amount of tea it holds has an important bearing on the actual moisture absorption itself. A bin that is partly full or almost empty, however air-tight it may be, is not so satisfactory as a full bin, owing to the extra air it contains. It must be

TEA MANUFACTURE IN CEYLON

borne in mind that each time a bin is opened fresh air with extra moisture is admitted. It will be well, therefore, when planning bin capacity, to consider the percentage outturn of grades and the time taken to collect each for a break.

The property that tea has of gaining or losing moisture and establishing an equilibrium with the humidity of the atmosphere explains why the moisture contents of the various days, make in a bin show little variation. As a rule, the tea in the upper and lower layers after storage will have a slightly higher moisture content than that in the middle. When a moisture determination had to be made before packing a grade, it will therefore be advisable to take samples from these three positions and bulk them. The figure obtained will give a fair representation of the moisture content of the whole of the tea.

It is not possible to state what the gain in moisture will be after storage since it will depend on the following factors:-

1. The period of storage.
2. The number of times the bin is opened.
3. The size of the bin in relation to amount of tea it holds.
4. The position of the bin and its condition.
5. The original moisture content of the tea put in.
6. General weather conditions.

The type of grade, it must be noted, affects the rate of moisture absorption only with respect to the size of the particles. Larger sized grades do not pack so closely as smaller sized grades, and are therefore apt to show a higher rise in moisture content owing to the larger amount of air between the particles. Whatever grades are broken or leafy their behaviour will be the same if they are packed the same way.

The Packing of tea—All the efforts to prevent teas absorbing too much moisture will be wasted if due care is not taken over their packing. Apart from the fact that tea chests must conform to certain standards, linings should be moisture proof, free from taint and strong enough to withstand transport conditions without damage.

In years gone by owing to unsatisfactory linings being used and sealings faulty, frequent complaints were made in regard to deterioration of tea during transit to London. For some time it was thought that the deterioration had been the result of packing tea with too high a moisture content. But it was also found that even teas despatched with a low moisture content had faded out.

Today, with the knowledge available on the relationship between moisture content and deterioration, and the availability of excellent packing materials, conditions such as those described should not arise. A tea should reach any part of the world almost as fresh as at the time of despatch. A certain amount of maturing cannot be avoided but the gain in moisture should not be more than half per cent if all suitable precautions are taken.

This means that teas may be packed safely with a moisture content of up to about 6%. But as a safeguard against linings getting torn or not properly sealed it would be better to work to a lower figure of 5%.

Without making any invidious distinctions between one type of packing material and another, it may be said that aluminium foil satisfies all the requirements for the packing of tea. It is light, easy to handle, durable, relatively cheap and makes a good air-tight package when the edges of the sheets are folded over.

STORAGE AND PACKING

Tea keeps equally well in plastic films which are gas resistant. But care must be taken not to use too thin a grade that may easily get torn or punctured by the abrasive effect of the tea. Sealing is not so easy as in the case of aluminium foil. It has to be done by a hot iron or cellulose adhesive tape.

With regard to tea chests, it should be emphasized that tea importing countries are not indifferent to their qualities. Though imported chests conform to trade requirements, some that are locally produced still continue to be below recognized standards. Badly seasoned materials are sometimes used and these attract boring beetles. Chests showing evidence of borer attack may be rejected by certain countries.

A further point to note in connection with tea chests is that they can either absorb or lose moisture just as tea does, especially if the wood is unseasoned. Chests should therefore always be dried before they are used. If they are stored in the vicinity of the firing room for a few days prior to packing no losses in weight will be incurred during transit.



CHAPTER 12

FACTORY ORGANIZATION

It has been said that "tea manufacture is a job for some one with an inventive mind and a gift for cooking." The phrase was probably coined at a time when very little knowledge was available of the more important factors that effect the quality of a tea. Undoubtedly a certain amount of skill is needed in manufacturing tea, but today there is little room for any views that may be held about tea manufacture being entirely an art. Haphazard methods of the past are giving way to rational methods and tea manufacture is gradually emerging from the trial and error affair that it used to be. The value of sound methods of control has come to be recognized, which in nutshell is proper organization.

Although there is a wide variation in manufacturing conditions between different factories, the principles involved in factory organization remain the same. Organization simply means an orderly arrangement of the different operations, beginning with the arrival of green leaf and ending with the firing of the tea. Subsequent operations like grading and packing are purely mechanical and do not require that degree of management essential to make success of the earlier processes.

It may appear to any observer that owing to the changeable raw material daily a rigid standardization in manufacture is not really necessary. At the same time it must be realized that if a wide margin of latitude is allowed chaotic results are bound to follow. A system of control, on the other hand, ensures that the best is being made of the leaf, that little is left to chance, and that if anything goes wrong with the teas the cause is more easily traced. Factory organization is concerned with the way this control must be applied to get the best results.

Tea manufacture is not only a question of getting the best out of the leaf. Its success depends on the production of teas of uniform quality. By having a system of control a reasonably consistent product is obtained. Clearly therefore this need will not be met if organization is lacking. The greatest advantage of a sound routine is that it brings about a more uniform product.

The first requirement for proper organization is that a factory must have sufficient withering space and machinery to deal with large crops with comparative ease. Equipment must be carefully planned in relation to the daily distribution of crop. A factory that is under-equipped cannot run efficiently and economically.

It would be uneconomic of course to provide extra withering accommodation and machinery that may be required on only a few days in the year, but it is always an advantage to have withering space in excess of average maximum requirements. Deficient machinery is not such a serious matter as inadequate space for spreading the green leaf. The only drawback of the former is that the working day is lengthened, whereas lack of withering accommodation will inevitably result in poor withers and congestion in the lofts when the following day's leaf is received.

The next requirement is that rolling equipment must match the capacity of the driers. This consideration had been badly neglected in the past. Either driers were installed in relation to the crop handled, but with insufficient roller capacity to keep them fully loaded, or the size and number of rollers were often far in excess of the intake of the driers. Badly matched equipment like this was to a large extent responsible for unsatisfactory results.

FACTORY ORGANIZATION

Successful running of a factory is not merely clearing a loft in the quickest possible time, or reducing the number of firing hours. The rate of stripping the leaf must be equivalent to the rate at which the drier is capable of handling it, and the latter, in turn, must be related to the output of the rolling room.

Drier Intake—The first thing to do, therefore, when planning manufacture on organized lines is to find the intake of the drier in terms of pounds of fermented leaf per hour. The next is to determine the most suitable roller charge and charging interval required to keep the drier continuously fed with leaf. When this is known organization in the withering loft becomes a relatively simple matter.

The intake of a drier of a certain size, run at a given temperature, depends on the wither. The performance of any particular drier will therefore not be the same in different factories or for that matter even in the factory in which the withers vary. The figures given in Table XXII will convey an idea of the extent to which the intake of a drier is affected by the wither. For the purpose of illustration a drier with an intake of 500 lb. fermented leaf per hour for a normal wither has been chosen.

Table XXII. *Effect of wither on intake of a drier*

Type of wither	Intake— Lb. fermented leaf per hour
Very soft	450
Soft	470
Normal	500
Hard	530
Very hard	550

The necessity for withering to approximately the same degree is evident from these figures. No rolling programme can be properly operated when withers are not constant. Since factory organization is primarily a system of control which depends for its success on a steady rate of dealing with leaf, roller charges and charging intervals have to be fixed beforehand. For the sake of argument assume in the illustration given that an initial charge of 500 lb. in conjunction with a 60 minute interval was adopted. If the wither is very soft, the batch of leaf will take 67 minutes to fire ($500 \div \frac{450}{60}$). Had that particular batch been withered very hard the drier would have dealt with it in only 54 minutes ($500 \div \frac{550}{60}$). The question may well be asked—Are these small differences of 6 to 7 minutes really serious? To answer this question the fermenting period has to be examined.

Fermenting Period—With a few exceptions which will be referred to later, one essential requirement in tea manufacture is that the period of fermentation must be constant from batch to batch. In fact one of the main purposes of organization is to ensure that the period of fermentation does not vary to any marked extent. Following the example already taken, suppose there are 10 batches, that rolling starts at 7 o'clock and the fermentation given to the first batch is 3 hours. Firing will then start at 10 a.m. The sequence of events is as in Table XXIII.

TEA MANUFACTURE IN CEYLON

Table XXIII. Effect of a very soft wither on period of fermentation.
(A batch taking 67 minutes to fire)

Batch No.	Time batch charged into rollers	Time firing commenced	Time firing ended	Period of fermentation Hours
1	7.00	10.00	11.07	3.00
2	8.00	11.07	12.14	3.07
3	9.00	12.14	1.21	3.14
4	10.00	1.21	2.28	3.21
5	11.00	2.28	3.35	3.28
6	12.00	3.35	4.42	3.35
7	1.00	4.42	5.49	3.42
8	2.00	5.49	6.56	3.49
9	3.00	6.56	8.03	3.56
10	4.00	8.03	9.10	4.03

In this example the last batch of leaf will have received more than an extra hour's fermentation, which is indeed not a trifling matter. On the other hand, consider very hard withered leaf, each batch of which takes 54 minutes to fire. If the drier is kept continuously fed, the last batch will then have an hour's shorter fermentation. For each batch to have the correct fermentation the drier will have to run empty between batches. This is a waste of time and consequently uneconomical.

These examples show one of the pitfalls encountered in a rolling programme. It may occur rarely in practice, but it must not be lost sight of because no factory can attain absolute perfection in withering. Allowance must be made for batch to batch and day to day variations. Every effort should, however, be made to minimize these.

Accordingly, to meet such contingencies, exact matching of roller and drier capacities is not a very good thing. Whenever possible, a programme must be so designed as to allow a certain amount of latitude in decreasing or increasing roller charges and drier capacities. That is to say, a firing machine should not be run at its maximum capacity and rollers should not be over-charged. Thus, if the wither happens to be soft there is always a margin for adjustment in the drier and if the wither is too hard the rollers can be charged with more leaf. Altering the charging interval will only result in disorganization in the rolling room.

Taking again the example given, the adjustments required to give the same fermentation to each batch will be as under :—

(A) *Very Soft Withers*—The charge can either be reduced to 450 lb. or the drier intake increased by about 10%. This can be achieved, if the drier is normally run slightly under capacity, by spreading a little thicker and opening the fan valve fully.

(B) *Very Hard Withers*—The initial charge can be increased to 550 lb. without having to adjust the capacity of the drier.

In certain circumstances having the same fermenting period for each batch may not always be the best policy. In factories lacking a proper humidifying system, low temperatures may be experienced in the mornings and much higher temperatures in the afternoons. Such conditions may alter the rate of fermentation throughout the day, necessitating lengthening of normal fermentation for the early batches or shortening it towards the end of the day. Compensation for changes in temperature may be made by reducing the weight of the initial roller charge. If it is fixed beforehand at an amount that will take a few minutes less to fire than the charging interval and the drier is kept continuously loaded, fermentation will get shorter as manufacture proceeds.

TEA MANUFACTURE IN CEYLON

Assume that the programme adopted after matching roller and drier capacities is as under:—

Initial charge or batch weight—600 lb.

Charging interval—60 minutes.

Drier intake—10 lb. per minute.

Standard fermentation—3 hours.

Number of batches—7.

It is desired to have say $3\frac{1}{2}$ hours fermentation for the first batch gradually reducing to 3 hours for the last batch. This means that since seven batches have to be dealt with, each should take 5 minutes less to fire. So instead of charging 600 lb. the batch weight is reduced to 550 lb. which will take 55 minutes to fire, but the charging interval remains unaltered at 60 minutes. Table XXIV makes this clear.

Table XXIV. *Shortening of fermentation by reducing batch weight.*
(Charge of 550 lb. for a charging interval of 60 minutes,
but for a drier intake of 10 lb. per minute.)

Batch No.	Time of charging	Time firing commenced	Time firing ended	Period of fermentation hours
1	7.00	10.30	11.25	3.30
2	8.00	11.25	12.20	3.25
3	9.00	12.20	1.15	3.20
4	10.00	1.15	2.10	3.15
5	11.00	2.10	3.05	3.10
6	12.00	3.05	4.00	3.05
7	1.00	4.00	4.55	3.00

It will be noted that for the reduction in fermentation to be brought about the drier need not have to run empty. When fermentation has been reduced to normal requirements, the charge can then be increased to the figure on which the rolling programme was first based.

Working on the same principle, fermentation periods can be gradually lengthened by increasing the batch weight. Varying the charge is thus a suitable means of having a full control over fermentation. It can be reduced, or increased, at any time of the day without in any way upsetting organization, or running the drier empty between batches. But to do so the weight of a batch must be so planned that rollers will not be under or over charged unduly when any adjustment has to be made.

The period of fermentation, as it is generally understood, refers only to the interval between the commencement of rolling and the time the first lot of leaf from a batch goes to the drier. It gives no indication whatsoever of the fermentation of the other dhools, which is governed by the size of the charge and hence the charging interval.

Charging Interval—This determines the range of fermentation, and the choice of short or long intervals depends on the type of tea required. On account of the difference in time between the longest and shortest fermentation being small in the case of a short interval, this should be preferred where high grown quality is the main consideration. A long interval is not so suitable for the preservation of this characteristic because, if the correct fermentation is given to the first lot of leaf of a batch, the tea that is fired last will receive a fermentation that might be detrimental to quality. For example, in a two hour interval, if firing commences 3 hours after rolling, the dhools fired later will be fermented

TEA MANUFACTURE IN CEYLON

from 4 to 5 hours. To prevent such over fermentation the first lot will have to be fed to the drier long before it can be considered correctly fermented. The range of fermentation, though long, limits the periods accordingly, and the risk of under-fermenting, or over-fermenting some of the leaf is therefore always present. In the low-country, where high-grown quality is absent and colour of a liquor is the more important feature, a long charging interval may not prove disadvantageous. However, in view of the definite limits imposed, shorter interval might be better.

Examining a short interval of say 45 to 60 minutes, it will be seen that there is more latitude for varying the fermentation to suit any requirement. The short range permits the shortening or lengthening of fermentation to any extent. The danger of some dhools not receiving the correct fermentation is considerably reduced. It can therefore be safely adopted in all factories at any elevation.

The exact charging interval has to be decided according to the roller capacity in relation to drier intake. It is not only the initial charge that must be considered. The capacities of the rollers used for subsequent rolls have also to be taken into account. If this point is ignored, possible snags are that rollers may be found to be over-charged, or of the initial charge is too small there may be insufficient leaf for the last roll. It is evident therefore that just as important as matching roller capacity with drier capacity for efficient organization, is the matching of rollers with one another according to the order in which they are used.

One requisite in a good rolling programme is that the output of the rolling room must be equal to the drier intake. The latter must therefore be checked and about 5% added to compensate for rolling room losses, in order to calculate the equivalent amount of withered leaf. Suppose a drier can deal with 600 lb. withered leaf per hour (or 10 lb. per minute). If the charging interval is 60 minutes, the charge will obviously be 600 lb. It may be varied to some extent to suit the rolling equipment, and still keep the drier full, To feed the drier uninterruptedly for different charging intervals, the initial charge will have to be as in Table XXV.

Table XXV. *Relationship between charging interval and initial charge*

Charging interval minutes	Initial charge Lb.
45	450
50	500
55	550
60	600
65	650
70	700

The choice of any of these intervals must be regulated by the rolling equipment. Whether it is 45 minutes or 70 minutes, it is not going to make any material difference to the fermentation of a tea. But one of the aims of factory organization, namely, the best use of the machinery, may not be realized if the period of rolling is not considered.

Rolling Period—This factor influences the interval by virtue of the fact that a certain interval of time must be allowed between the discharging of a roller and recharging it with another lot of withered leaf. If the interval is too short the filling up operation is not carried out satisfactorily; if too long, the machine remains idle. Cleaning a roller during this period also takes a little time. Whatever the size of the roller,

FACTORY ORGANIZATION

experience shows that discharging, cleaning and refilling it with leaf from the batch that follows cannot be done properly in less than 15 minutes. The maximum period that may be allowed is 20 minutes. In fact this extra 5 minutes is of great help sometimes, when towards the end of a day labourers tire and their rate of work diminishes. It is uneconomic to plan a programme in which there is an interval of time longer than 20 minutes between the end of the first roll of one batch and the beginning of the first roll of the next. If it is found to be necessary, then evidently equipment is at fault.

Now taking the range of charging intervals shown in Table XXV, it is clear that an interval longer than 50 minutes is unprofitable for a 30 minute roll. For a 40 minute roll, a 50 minute interval will be too short and anything longer than 60 minutes means that rollers will be idle. Two short rolls of 25 minutes' duration each may be squeezed into a 70 minute charging interval by using the same machine for two successive rolls to make the best of the time, but if the machine is reserved for only the first roll the duration will have to be prolonged to as much as 50 minutes to use rollers economically.

These are some of the points that must receive consideration when drawing up a rolling programme. The range of rolling periods in Ceylon tea factories is 15 to 40 minutes. The most suitable charging intervals will therefore vary considerably if economy and ease of working are both taken into account. It is suggested that the intervals given in Tables XXVI and XXVII be the basis in cases of doubt. The figures in Table XXVI deal with the case where one or more rollers are allocated for one particular roll, namely, the first. In Table XXVII a roller used for two successive rolls (the first and the second) is considered.

Table XXVI. Relationship between rolling period and charging interval when one or more rollers are used for the same roll.

Rolling period minutes (1st rolls)	CHARGING INTERVAL	
	Shortest mins.	Longest mins.
15	25	35
20	30	40
25	35	45
30	40	50
35	45	55
40	50	60

Table XXVII. Relationship between rolling period and charging interval when the same roller or rollers are used for successive rolls.

Rolling period minutes (1st & 2nd rolls)	CHARGING INTERVAL	
	Shortest mins.	Longest mins.
15	50	70
20	60	80
25	70	90
30	80	100
35	90	110
40	100	120

TEA MANUFACTURE IN CEYLON

There is not much scope for varying the rolling period at will once a programme has been decided upon, because if this is done roll-breaking arrangements are upset. The essence of a good programme is the availability of a roll-breaker exactly at the time a roller is discharged. Rollers should not be kept waiting for roll-breakers, nor leaf left lying about for want of a roller. If different rolling periods are found to be necessary, the rolling programme must be most carefully planned beforehand to ensure smooth working. Designing a programme for varying rolling periods is much more tedious than drawing out one for rolls of a fixed duration.

Roll-breaking—For maximum efficiency a roll-breaker should not remain idle. Long periods of idleness invariably mean wasted labour. A roll-breaker crew generally consists of three and forms a considerable proportion of rolling room labour. The necessity for using the minimum number of machines is apparent.

In a small sized factory, consisting of 4 to 5 rollers, one roll breaker should be ample. An average factory can well manage with two and it is possible with good organization for the larger factories to be worked with only three. Only in very exceptional circumstances will more be needed.

The number of roll-breakers required in a factory should never be based on the number of rollers. Actually if roll-breakers of extra large capacity are marketed, even the largest factories in Ceylon today could be equipped with only one machine. In Table XV (page 76) the capacities of current roll-breakers are given, from which it will be seen that the largest available can deal comfortably with only 60 lb. per minute. An initial charge of 1,000 lb. will thus take more than 15 minutes on the roll-breaking operation alone. With the extra time taken for cleaning the mesh, and conveying leaf to and from the machine, a period of at least 20 minutes will be required. When a long time has to be spent on roll-breaking, the same machine will not be available for other dhools from subsequent batches.

The number of roll-breakers a factory requires is accordingly dependent on their capacity. Inadequate capacity is a common trouble and here again it must be stressed how necessary it is to have roll-breaker capacity in excess of actual requirements. Except in the very large factories that must preforce still rely on relatively small roll-breakers there is no excuse for any factory being equipped with under sized machines. The essence of good organization is smooth working, and it will be a pity to sacrifice this for the sake of misguided economy.

The charging interval is a very important factor which determines the number of roll-breakers required in a factory. Inadequate rolling equipment, for instance, necessitating shortening of the charging interval with a view to keeping driers fully loaded, entails more roll-breakers.

The number of rolls and their duration are two other factors which govern the number of roll-breakers. Without going into these in detail it may be said that more machines are required when a greater number of rolls are carried out and rolling periods short.

When more than one roller is charged it may be possible to use only one roll-breaker by staggering charging times thus enabling the machine to handle all the leaf. Much ultimately depends on how it is fitted in the programme so that it is free when required. The real crux in a rolling programme is to avoid clashing of roll-breaker times. A small difference of even a few minutes in a charging interval or a roll-breaking interval may involve the use of two roll-breakers when only one may have been needed in a well arranged programme.

FACTORY ORGANIZATION

The time allowed for roll-breaking is a matter of considerable importance when planning a programme. It has to be related to the period of rolling and the charging interval. For example, in a 4×30 minute roll programme with a 40 minute charging interval, if 10 minutes have been allocated for the roll-breaking interval, at the end of the fourth roll of the first batch 4 rollers will be discharged at the same time, necessitating 4 roll-breakers. The number can be reduced to 2, if 10 minutes are allowed for only the first rolls, and 5 minutes for the rest. But, if rolling periods are 20 minutes each, the whole programme can be operated on only one roll-breaker, by allowing a roll-breaking interval of 10 minutes for all the rolls.

Mention was made earlier about the advantage of having different sizes of mesh for different dhools. In a factory needing only one roll-breaker the provision of an extra machine with different mesh will enable one to be reserved for the early rolls whilst the other is used for the later rolls. Where two or more roll-breakers have to be used at any single time, it is preferable, however, to have identical machine from the point of view of organization.

Any undertaking involving many operations cannot be a success unless it runs to a definite time schedule. Rollers must be charged and discharged at specified times, and roll-breakers always free when required. To arrange in detail these different operations a rolling programme must be set out on squared paper. The form of diagram that has been found to be most convenient, is one in which rolling and roll-breaking periods are represented by rectangles (see diagrams 1, 2 and 3). It is easier to map out a programme on these lines, than trying to find out how many roll-breakers fit in by calculating the time of each roll in recurring batches.

The Rolling Programme—The principles of rolling programmes have been discussed. The importance of good organization cannot be over-emphasized. It is the biggest deciding factor in the success or failure of manufacture and must be kept at the highest possible pitch of efficiency. It would be idle to suggest that this degree is easy to attain, or that in any factory it is reached completely. Nevertheless, it must not be imagined that since perfection is not attainable small details are unimportant. Every precaution must be taken to reduce shortcomings to a minimum. Special pains must be taken in planning a rolling programme. It is not a simple task, involving as it does the avoidance of the following:—

1. Overcharging or undercharging of rollers.
2. Driers running empty between batches.
3. Accumulation of fermented leaf and lengthening or fermentation periods.
4. Clashing of rolling or roll-breaking times.
5. Using too much equipment.

None of these details can be left out and however burdensome it may be to examine them in relation to each other, the efforts towards this end will be well rewarded. Owing to the wide variation in equipment and manufacturing conditions in different factories, programmes such as those given in diagrams 1, 2 and 3 can only serve to show some of the pitfalls that may be overlooked.

For the purpose of illustration, assume a factory is equipped with one drier having an intake equivalent to 10 lb. withered leaf per minute.

TEA MANUFACTURE IN CEYLON

one roll-breaker and four rollers of the following sizes :-

- A 45" for first rolls
- A 44" for second rolls
- A 40" for third rolls
- A 34" for fourth rolls.

It is decided to carry out 4×30 minute rolls and take out 10%, 20% and 30% dhool from the first three rolls.

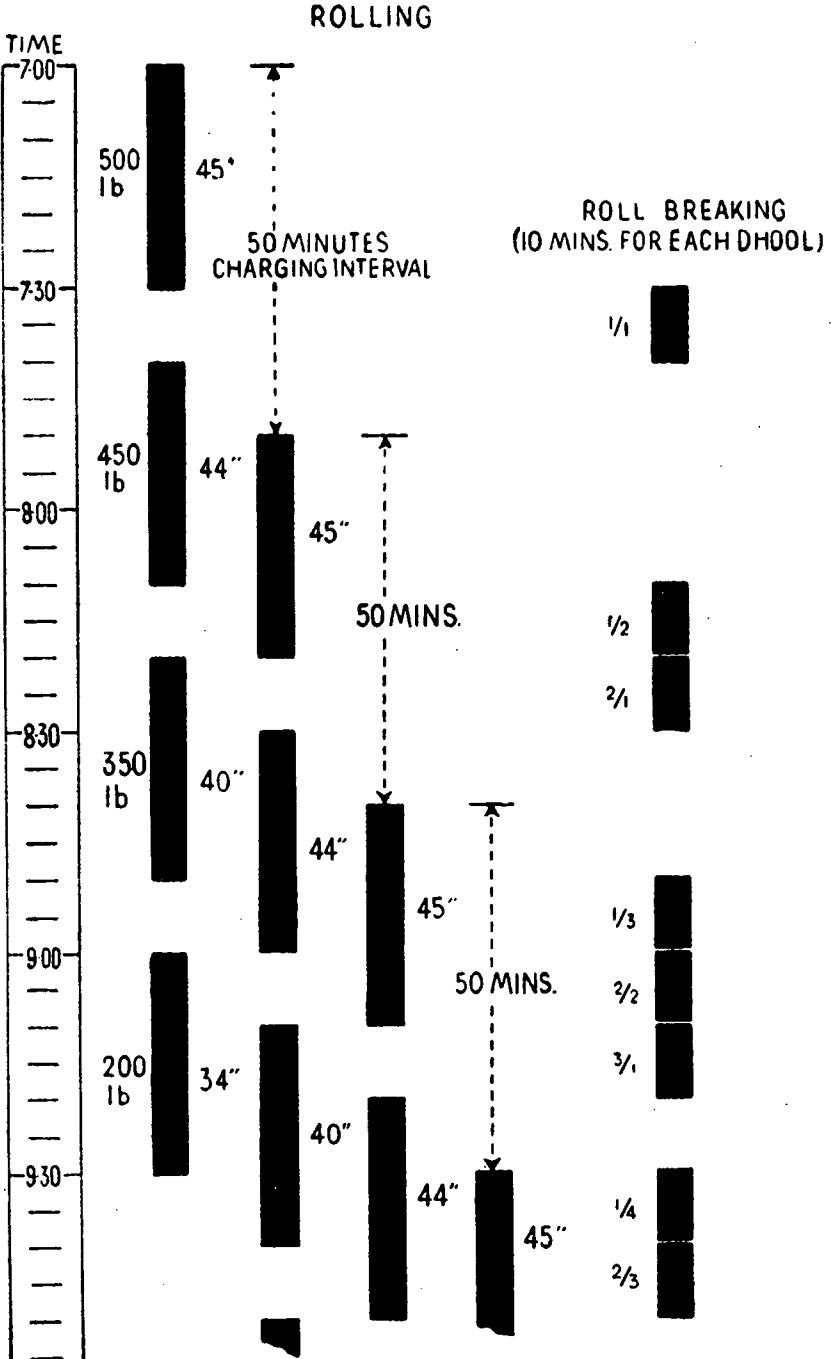

DIGARAM I. A well arranged 4×30 minute roll programme, using 4 rollers and 1 roll-breaker

FACTORY ORGANIZATION

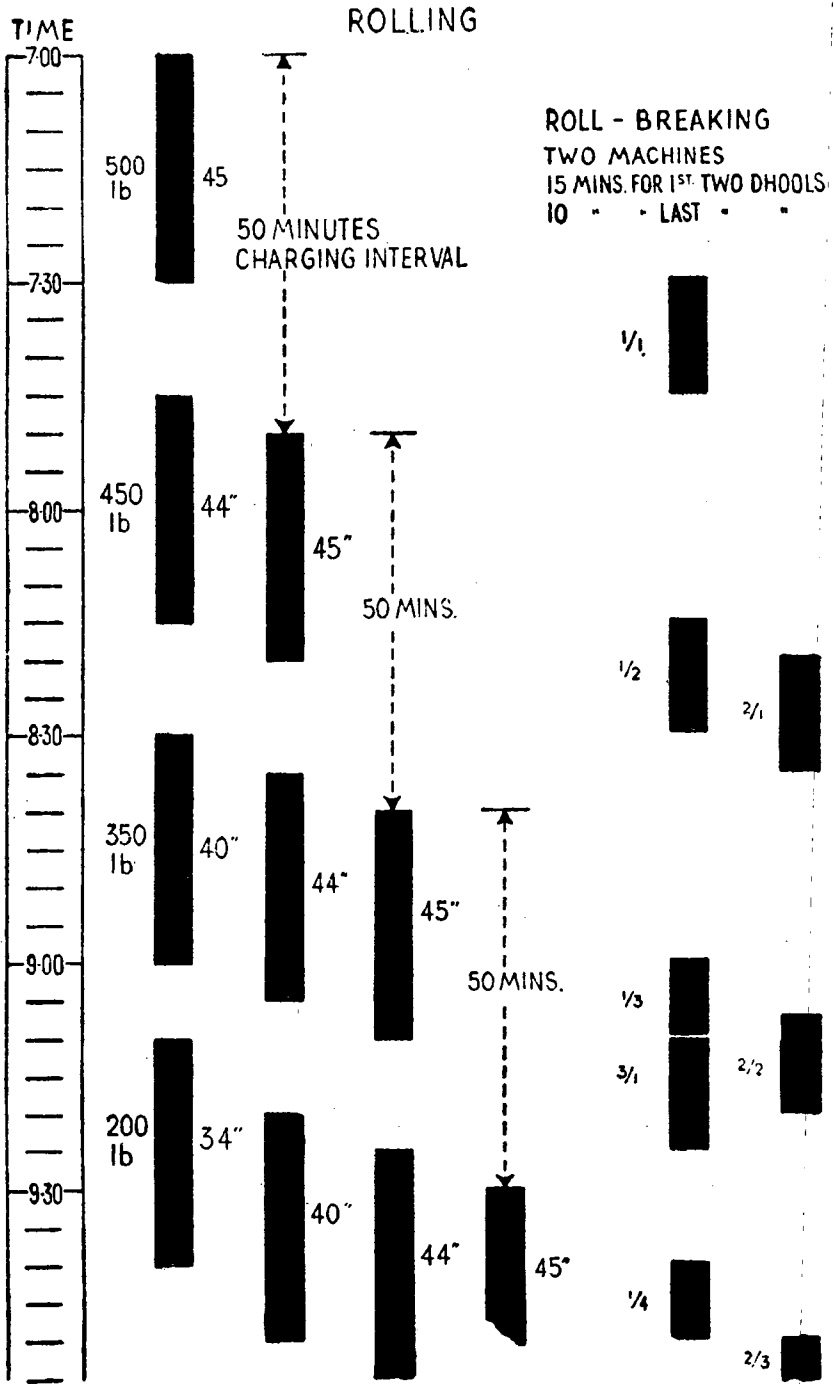

DIAGRAM. 2. A 4 × 30 Minute roll programme for 4 rollers but requiring 2 roll-breakers

TEA MANUFACTURE IN CEYLON

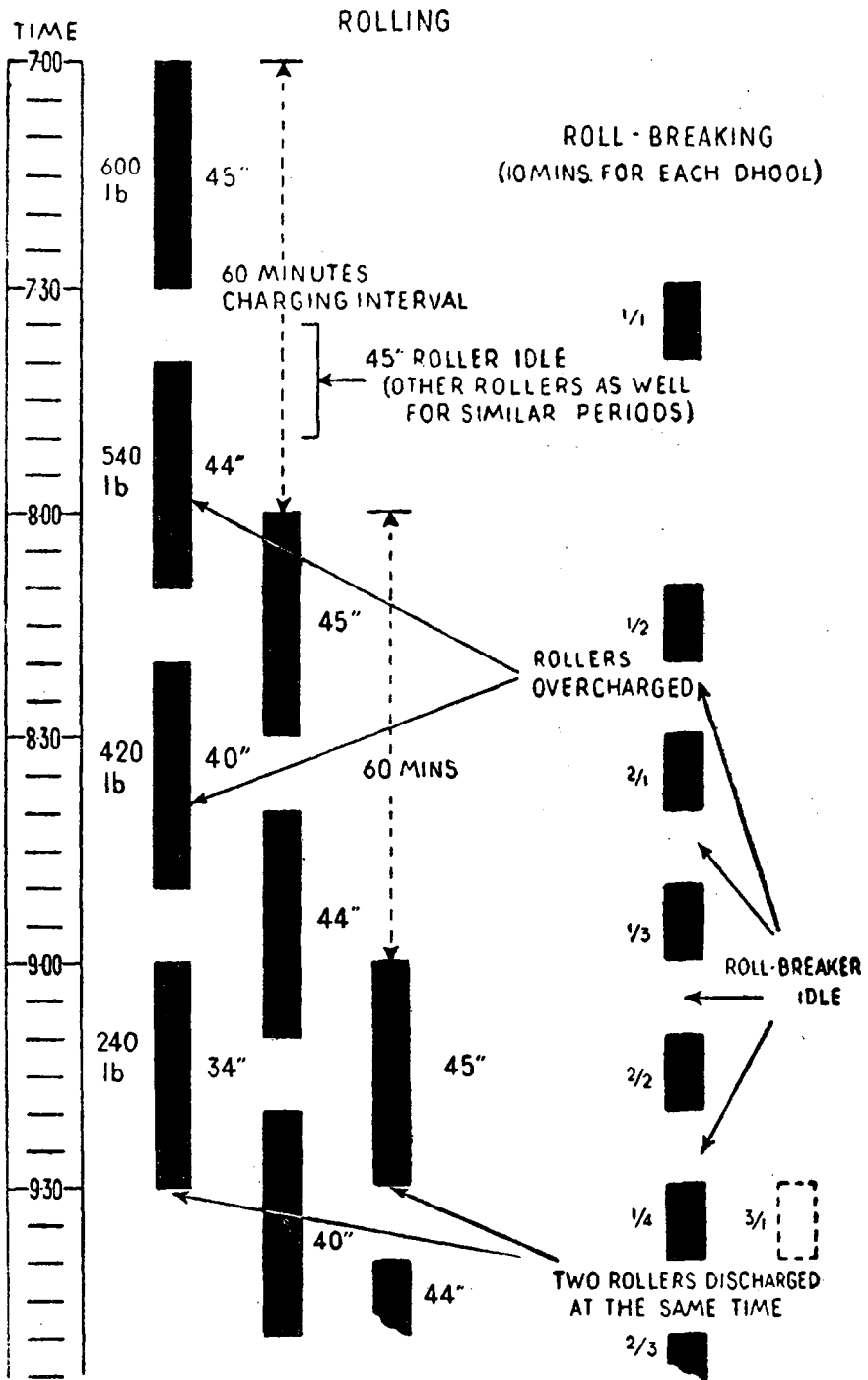

DIAGRAM. 3. A badly arranged rolling programme for 4 rollers and 1 roll-breaker

FACTORY ORGANIZATION

Diagram 1 shows how the best programme may be planned. The single roll-breaker fits in very well, machines are not idle, and all roller charges are at their optimum.

In diagram 2, the programme is not so well arranged; as a result of not allowing the same number of minutes for roll-breaking of each dhool and not making a suitable adjustment in the charging interval, an additional roll-breaker has to be put into service.

The programme shown in Diagram 3 is badly arranged and uneconomical. Rollers are over-charged in the second and third rolls because of the higher initial charge. Machines are idle for longer periods owing to the longer charging interval, and there is a clashing of roll-breaker times when the last roller is discharged. It must be noted that in this programme as well the output of the rolling room matches that of the drier intake. If, to avoid rollers being over-charged, the initial charge is reduced to the figure of 500 lb. as in programme 1 and 2, there will be a gap of 10 minutes in the firing between batches.

When rolling programmes are drawn as outlined, it is possible to foresee snags that would otherwise not be experienced till a programme is actually put into operation. When the final programme has been adopted the next step is to draw up a time table for each roller. This can be put on a permanent footing by setting the rolling room clock at some pre-determined figure each day rolling commences. Suppose it is 7, roller time tables for programme 1, will be as in Diagram 4.

Diagram 4. ROLLER TIME TABLES

<u>45" roller (1st rolls)</u>	<u>44" roller (2nd rolls)</u>
Set 1 7.00— 7.30	Set 1 7.40— 8.10
,, 2 7.50— 8.20	,, 2 8.30— 9.00
,, 3 8.40— 9.10	,, 3 9.20— 9.50
,, 4 9.30—10.00	,, 4 10.10—10.40
,, 5 10.20—10.50	,, 5 11.00—11.30
,, 6 11.10—11.40	,, 6 11.50—12.20
<u>40" roller (3rd rolls)</u>	<u>34" roller (4th rolls)</u>
Set 1 8.20— 8.50	Set 1 9.00— 9.30
,, 2 9.10— 9.40	,, 2 9.50—10.20
,, 3 10.00—10.30	,, 3 10.40—11.10
,, 4 10.50—11.20	,, 4 11.30—12.00
,, 5 11.40—12.10	,, 5 12.20—12.50
,, 6 12.30— 1.00	,, 6 1.10— 1.40

These time tables can be continued indefinitely. The great advantage they possess is that they do away with the daily job of chalking up times right through the rolling process. Also things are made easy for supervisors and operators.

Once thorough organization has been achieved, record keeping is reduced to a minimum.

TEA MANUFACTURE IN CEYLON

Factory Records—The collection of records in a tea factory, though highly commendable, should not be overdone. The time wasted on recording important data may will be spent more profitably on supervision. It is not very necessary to record daily details of what takes place in the withering lofts, rolling room and firing room. If the days manufacture has been carried out in the way it has been originally planned as it should be of what use is such information as time the rolls are charged, time the driers are fed, weights of charges, dhool outturns, fermentation periods, rolling periods, and so forth?

One important contribution from efficient organization is standardization of manufacture to give consistent results. Such records, as mentioned above therefore serve no useful purpose. It is not improbable that, if these are insisted on, the same figures may be recorded day by day, from which dangerous deductions may be drawn. A personal check now and again of actual manufacture will yield far more fruitful results than any number of records.

What should really be recorded is some phenomenon that might have a marked effect on the tea, such as a short wither due to abnormal weather conditions, or an exceptionally hard or soft wither, or an unduly high temperature in the lofts and the like. Records of routine determination, such as those of outside temperatures and hygrometric difference in every part of the tea factory are of little value. What is of value is that bit of information which should be noted when something goes wrong, but strange to say the average factory record book contains no such data.

There are some records of course that must be kept a routine procedure. These are the weights of green leaf, fired tea, sifted tea, packed teas and fuel consumption. But these too, if they are to be useful must receive frequent checks.

For those who wish to check the daily manufacture the specimen record sheets given in Appendix G are suggested.

CHAPTER 13

TEA CHARACTERISTICS AND COMMON DEFECTS

A description of the main characteristics of a tea was given in Chapter 2, but there are many other properties which may affect market value. Some are linked with those already mentioned whilst the others are entirely independent. Any attempt to improve manufacture is a waste of time if the terms used by a tea taster to describe a tea are not clearly understood.

Many tea-tasters' glossaries have been published from time to time but they have not been of much assistance in suggesting possible lines on which manufacture should be carried out to get the best results. In fact if some of the causes given for any particular defect were to be accepted as a basis for making an alteration in manufacturing technique unexpected results would follow. It is proposed therefore to give some guidance in this matter to enable one to make a possible rectification of a short-coming in a tea.

Some terms used by a tea taster convey little information as to whether the characteristics they signify are the result of inherent properties, seasonal variations or factory procedure. Some are self-explanatory, whilst a few may not convey the exact meaning. Thus the terms "earthy" "weathery," "metallic," "fruity," "sweaty," "coarse," and "nose," are vague and may have no connection with the type of manufacture carried out.

The definition of most terms in current use has, however, been more or less standardized and a glossary of these is given in the next chapter. Terms that explain themselves are omitted. Uncommon terms are not dealt with, and may better be left to a tea taster who used them, to indicate what they actually connote.

The conditions which may contribute to the more common characteristics of a tea are given below.

Tip—The term 'tip' is used to describe that portion of a tea which originates from the bud. For it to be produced hairs must be present on the bud. The way the juices are distributed over the hairs, and the amount of hair present controls the colour of the tip. If hairs are not present as a result of peculiar conditions of growth or rough treatment tip cannot be made.

The colour of the tip may be golden, silvery, grey or black.

(A) *Golden Tip*—Orange in colour. Produced when a large amount of hair is present on the buds and manufacture carefully carried out. To get the maximum colour, leaf should be carefully handled, the wither good and rolling not too hard.

(B) *Silver Tip*—This is generally produced when the wither is hard or when the hairs are insufficiently coated with juice as a result of very light rolling.

(C) *Grey Tip*—The main cause is damage during sorting. It also results from a disorderly arrangement of the hairs that may be brought about by over-rolling. Some of the hairs are removed and the mixture of a golden and black colour appears grey to the eye.

(D) *Black Tip*—This is almost indistinguishable from the tea and is not due to over-firing. It is purely associated with the absence of hairs on the bud.

TEA MANUFACTURE IN CEYLON

General Appearance of a Tea—What accounts for black, brown and grey has been fully discussed in previous chapters.

The blackness of tea is, in the main, due to the dried juices coated on its surface, but if the tea is flaky it will not appear so black. When this coating is scraped off the appearance is grey and a certain amount of soluble matter is also lost. A tea gets blacker on storage, but the cause is obscure.

Brown teas generally result from low jat leaf. Since they contain less sap and do not twist so well as high jat leaf, they cannot be as black. The brownish colour of a tea is rarely due to any fault in manufacture. Over-withering to the extent that certain parts of the flush become dried out is the only cause. Coarse, tough leaf accentuates the brownish effect.

The colour of the dry leaf is also influenced by the firing temperature. High firing temperatures tend to produce blacker teas. Another factor is the age from pruning. As a rule, old leaf is not so black as young leaf, and this is again due to the more flaky nature of the tea and the less juice contained in the leaf. Contrary to widely held beliefs, hard withers produce just as black teas as soft withers, provided rolling has been satisfactorily carried out.

The flakiness of a tea arises from numerous causes. It may be the leaf itself, under-withering or over-withering, under-rolling or over-rolling, or insufficient winnowing.

The terms “uneven” and “mixed” describe teas that are not properly graded.

Colour of a Liquor—This is a characteristic easy to assess, variations of the property being denoted by the terms “light,” “coloury” and “muddy.” It is usually associated with strength and is indirectly connected with quality.

(A) *Light Liquor*—This is one that lacks depth of colour and not to be confused with the term ‘thin’ which indicates a tea lacking in strength. It does not necessarily denote a tea that has been under-fermented. Some of the best quality teas are usually light. It cannot be regarded as a defect and if any methods are adopted to produce more colour in a liquor they may tend to diminish quality.

(B) *Coloury Liquor*—When a liquor possesses the required depth, and is bright and clear it is described as coloury. A full fermentation for the optimum period is the condition required (See Fig. 18).

Colour in a liquor can be slightly improved by a soft wither, when hard rolling cannot be carried out.

(C) *Muddy Liquor*—An over-fermented tea. The tea loses its bright colour and is dull, brownish as distinct from the bright red coloured liquor of a well fermented tea.

It must be noted that the colour of a liquor is to a marked extent influenced by the fermenting properties of the leaf. These must be determined before any alterations are made in fermenting periods.

The method of rolling must also be examined when liquors lack colour, because it is the amount of juice extracted from the leaf which ultimately determines the colour of a liquor. Lengthening of a fermenting period with a view to improving colour must never be done till the fermenting properties and rolling procedure are carefully examined.

Strength (Good Body)—A tea lacking in strength or ‘fullness’ is described as thin, weak or washy, and is caused by under-rolling. The period of fermentation does not have a marked effect on the strength of a liquor except when it is unduly prolonged. The tea then becomes soft.

TEA CHARACTERISTICS AND COMMON DEFECTS

The strength of a liquor is entirely dependent on the amount of soluble matter in the leaf and therefore varies according to the number of leaf cells ruptured. A thin liquor can best be corrected by extra or harder rolling to express more sap from the leaf.

A strong liquor on cooling becomes cloudy as a result of some of the compounds soluble only in hot water being precipitated from the cooled liquor. This is referred to as 'creaming down.' A thin liquor does not cream or takes a very long time to do so.

Besides indicating strength, the colour of the cream provides a reliable test for judging the quality of a liquor. A light, brown colour with a reddish tint and bright, is indicative of good quality. A dark, muddy cream is always associated with inferior teas.

Softness in a liquor—Teas without "briskness" are soft. The difference between these terms may be illustrated by the difference between a freshly opened soda water and one that has become 'flat.' Thus a soft tea has no "live" characteristic. A "flat" tea is very soft. The term "point" indicates accentuated briskness.

The most likely cause of a tea going soft is over-fermentation, or excessive gain in moisture during storage. Firing to too high a moisture content which results in stewing conditions, and case hardening, may also cause softness.

A brisk tea on the other hand, is one in which fermentation has been checked at the correct time, properly fired and well preserved.

Greenness of a Liquor—A greenish liquor is also described as hard, raw, harsh and bitter. Greenness may be mistaken for pungency. The real difference between the two is that a greenish liquor is bitter whereas a pungent liquor has astringency without bitterness. Greenness is normally due to under-fermentation. The reverse of greenish is mellowness. The "smooth" and "round" denote the same thing.

Greenness is a characteristic that may be inherent in the leaf. At one time it was supposed to be due to under-withering. There can be no doubt, however, that if it is consistently present to a marked degree it is an intrinsic character, and no method of manufacture so far known is able to eliminate it.

Degree of greenness may, however, be reduced by the following measures:—

1. A longer period of wither.
2. A higher temperature in withering.
3. More rolling.
4. A longer period of fermentation.

It must be remembered, however, that the improvement will be achieved at the expense of quality.

Maltiness of a Liquor—This is a puzzling feature, wrongly believed to be caused by high-firing. A malty liquor is also described as "nutty". There is evidence to suggest that it is an inherent characteristic. Whatever that fact is, it is considered to be a desirable property in a tea.

Infusion—It is necessary to emphasize at the outset that the colour of the infused leaf is not necessarily related to the liquor. It is primarily an inherent character and there appears to be a tendency to overstress its importance. It rarely gives an indication of the liquoring properties of a tea except perhaps when it is very bright or very dull, but even then it is apt to be misleading.

TEA MANUFACTURE IN CEYLON

Just as in the case of an inherently greenish liquor a greenish infusion cannot be given the 'new-penny' look by an alteration in manufacturing procedure, but it is accentuated by hard wither, insufficient rolling and fermentation, and by coarse leaf. A greenish infusion resulting from an inherent property of the leaf can sometimes be easily distinguished from one caused by insufficient fermentation. The latter would appear dull and 'dead' as opposed to the former which would not be strictly green and might even be bright if the tea has been properly manufactured. The greatest care should therefore be taken in trying to correct a tea with a greenish infusion. Though a longer period of fermentation would be beneficial in one case it would spell ruin to the other.

A mixed or uneven infusion is generally due to uneven jat or the mixing of grades. Two manufacturing faults that may contribute to a mixed infusion are over-charging of rollers and the use of too large a roll-breaker mesh. Uneven withering may also bring it about.

A dull infusion may be a character originally present in the leaf but it may also arise from faults such as long withers, high temperatures in withering, high temperatures in rolling, or unclean fermenting surfaces.

There is no doubt that a dull infusion detracts from the value of a tea and, although it may or may not be associated with good liquoring properties, it is considered a derogatory characteristic by a taster. It is therefore imperative to avoid the conditions that may lead to it, particularly at certain seasons of the year when, owing to unfavourable weather, the infusion tends naturally to be duller. However, the fact remains that a bright infusion is generally the result of careful manufacture, irrespective of whether it is green or coppery. So long as a value is placed upon the infused leaf by the trade, the producer has no option but to make the infusion as bright as possible. The colour of an infusion during the process of fermentation can normally be expected to change from green to reddish or some variation in colour between, or at least it changes to a better colour. It can at the same time change from dull to bright or bright to dull or remain bright or dull throughout normal fermentation. In certain cases, therefore, a dull infusion cannot be corrected by altering the period of fermentation.

A few observations on infusion are given below to show some of the misconceptions which exist on it.

1. Greener infusions can be expected from the bud and first leaf than from the second and third leaves although the liquors from the former are appreciably better in quality and flavour.

2. Short withers are generally assumed not to give coppery infusions. This is a complete fallacy.

3. It is also nonsense to imagine that teas possessing greenish infusions do not keep well.

4. Coppery infusions can be produced from hard withered leaf. On the other hand greenish infusions can result from the most perfect withers.

5. Three year old leaf from pruning may very well give very dark and green infusions.

6. During the flavoury season some teas, particularly Uvas with fine flavour may have quite unattractive infusions.

These few examples illustrate how dangerous it would be to attempt to change the colour of an infusion when a more important matter as the liquoring property of a tea is at stake.

TEA CHARACTERISTICS AND COMMON DEFECTS

The hints given above may help to diagnose some common defects in teas, but to trace the cause actually responsible experimentation is necessary. Only one change in manufacture must be made at a time. Disregard of this warning may render an experiment valueless.

Factory Experiments—Empiric experiments carried out at random will lead nowhere. Much energy will be wasted through such endeavours to improve a tea. Accurate methods are necessary to get reliable results from an experiment carried out on a commercial scale.

Strictly controlled conditions are impossible to attain in any factory on account of the wide variability of the raw material and the poor facilities available for strict comparison between one treatment and another. Nevertheless, by repeating an experiment a number of times, and recording reliable data, a problem may be solved, but allowance must always be made for changes in the weather or any other variable factor.

It is no easy matter, therefore, for an estate to develop a manufacturing technique best suited to its conditions. Much time and individual effort is required. This naturally calls for the closest attention to detail in manufacture, not the least important feature of which should be methodical working.

In conclusion, it need hardly be stressed that standardization of manufacture should be the objective towards which efforts should be directed because just as important as making the best of the leaf the standard of the tea must be as uniform as possible. But organization will not be of much assistance in maintaining an uniform standard if the leaf received daily for manufacture varies considerably in the standard of plucking and age from pruning. Every effort should therefore be made to adopt a plucking and pruning programme which will ensure not only a uniform standard of plucking but also an even distribution of young and old leaf throughout the year.

CHAPTER 14

TEA TASTERS' TERMS

In the last chapter a number of terms were described dealing mainly with the adverse characteristics of a tea, their origin and possible methods of rectification. Occasional reference have appeared in this monograph to other terms in current use. These have now all been collected here for easy reference and additional terms not previously mentioned are also included. This glossary is broadly based on the lists published in the *Tea Quarterly*—Vols. VII and VIII.

APPEARANCE

Black—Leaf black in colour, a descriptive term usually applied to low-country teas and those made from high jat leaf. Most teas are black, but unsatisfactory withering, under-rolling and excessive handling reduces the degree of blackness.

Bold—Refers to size of leaf and indicates that the pieces of leaf are big.

Brownish—Mainly describes teas made from low jat leaf which are never really black. The term, however, may be used in the case of teas which have become brownish as the result of faulty methods of manufacture and bad plucking. See 'choppy,' 'flaky,' 'grey' and 'stalk'.

Choppy—Leaf chopped in a breaker or cutter rather than broken in the roller.

Even—Leaf true to grade and consisting of pieces of roughly equal size.

Flaky—Leaf not twisted, but in flakes. Results from poor withers under-rolling and excessive breaking or cutting of the made tea, and also from the manufacture of hard leaf. Insufficient winnowing is also a contributory cause. Flaky teas do not appear as black as well twisted leaf.

Grainy—Term applied to well made fannings and dusts, as opposed to 'leafy'. A grade which is grainy is generally smaller in size than one which is leafy.

Grey—Leaf grey in colour. Results from too much cutting and excessive handling during sifting.

Since the colour change is due to the dried coating of juices on the leaf being rubbed off, a loss of some soluble matter must be expected when a tea becomes grey.

Irregular—Uneven grades.

Leafy—Used to indicate rather bold leaf in broken grades, particularly in fannings.

Make—A well made tea, true to type and appearance.

Mixed—Leaf of different grades and size bulked together.

Open—See 'flaky.'

Ragged—A tea that is not carefully graded, being uneven and irregular in appearance and size.

Stalk—Applies to the presence of red pieces of stalk in a tea. Its method of elimination obviously lies in an improvement in the standard of plucking and extra care taken in picking it out during sorting.

TEA TASTERS' TERMS

Tip—Term used to describe the silver or golden coloured pieces of leaf. Unless hairs are present on the buds of a shoot tip cannot be made. It can be destroyed by over-withering, hard rolling and excessive handling.

Tip is a feature of low-country teas and seldom or never enhances the value of an up-country tea.

Wiry—Term used for a very well twisted O.P. of thin leaf as opposed to 'open.'

INFUSION

(The infused leaf)

Bright—A good colour and need not necessarily be coppery. A favourable characteristic, generally denoting a good tea.

Coppery—Describes the infusion of a tea which is copper coloured. It is more an inherent character than one developed in the process of manufacture.

Dark or dull—Dark brownish or dull green in colour, as opposed to 'bright.'

A derogatory characteristic rarely associated with a good liquor, and may at times be a natural property of the leaf. Manufacturing conditions which bring about it are heat, over-fermentation and bacterial infection.

Greenish—Mainly an inherent character unless it has been the result of under-rolling and under-fermentation. A bright greenish infusion is not unfavourable.

Mixed or Uneven—An infusion of different colours. Results from mixed jat, coarse plucking and under-rolling. Hard rolling and the use of small roll-breaker mesh would bring about an improvement.

LIQUOR

Bakey—An over-fired tea.

Body—A strong liquor as opposed to one which is 'thin'. The difference between these terms may be illustrated by the difference between watery milk and full rich creamy milk.

Generally speaking, liquors from high jat leaf possess more 'body' than those from low jat leaf. In manufacture, insufficient expression of juice from the leaf is the main cause of a tea lacking 'body' or 'fullness'.

Brassy—A term seldom use for teas made by orthodox methods. May refer to a liquor with a bitter taste. A possible cause is unwithered leaf.

Bright—Bright in colour and clear, as opposed to 'dull', with some briskness.

Brisk—Having a 'live' characteristic. A tea properly fermented, correctly fired and well preserved. Opposite of 'soft.'

Character—Prominence of some special characteristic which may be pungency, quality or flavour peculiar to the district from which the tea comes.

Coarse—A liquor which may have some strength but is deficient in quality. Some low-country teas are supposed to have a 'coarse' character.

Coloury—This term is used to describe a tea which possesses sufficient colour to bring it into a special category.

TEA MANUFACTURE IN CEYLON

As a rule, teas from low jat leaf are less coloury than those from high jat leaf. Colour can be improved by extension of the withering period, hard rolling and long periods of fermentation.

Cream—A cloudiness obtained when a strong tea cools.

Dull—An undesirable characteristic in a tea mainly caused by over-fermentation. Opposite of 'bright.'

Dry—Slight bakiness.

Flat—Denotes a tea that has gone off. No 'live' character and opposed to 'briskness'. It is generally the result of over-exposure, and is also due to storage at too high a moisture content, or for too long a time.

Flavour—The distinctive aroma of high grown teas, made during cold and dry weather.

Fruity—This term may denote a taint or some peculiar characteristic of the tea arising from very long withers and leaf kept too long in a wet condition. The liquor acquires an over ripe taste.

Full—A strong, coloury tea with no bitterness or coarse character.

Gone off—See 'flat.'

Greenish—A bitter taste and an unpleasant astringency. May be an inherent character. Can be caused by over-withered leaf and under-fermentation.

Harsh—Teas with too green a character.

Light—Not to be confused with 'thin.' Pale in colour but does not necessarily denote a poor tea. Some of the best high grown teas are light, mainly due to a property of the leaf.

A frequent cause of light liquors is tough banji.

Probable manufacturing faults:—over-withering, under-rolling and too short a fermentation.

Malty—An inherent character of the leaf. The way in which, or the stage at which, it is developed during manufacture is still obscure. It is a desirable characteristic.

Mature—A term used to distinguish a fresh tea from one that has been stored for some time. As a result of 'post fermentation' occurring after a tea is fired, it loses some of its astringent character and becomes 'mature.' It should not be 'flat,' but have a 'round' 'mellow' character.

Mellow—Opposite to 'greenish,' 'harsh,' 'raw,' 'rasping,' etc.

Metallic—See 'brassy.'

Nose—Means some aroma on the dry leaf or in the liquor. May be good or bad.

Plain—Lacking in desirable characteristics, particularly quality. Generally describes a liquor with no standout character. May be brought about by seasonal changes, rapid growth, coarse plucking and any method in manufacture which destroys quality.

Point—Accentuated briskness and a very desirable characteristic. See 'brisk.'

Pungent—Astringency without bitterness. May mean a tea with more marked 'point'. A seasonal characteristic, which can be destroyed by prolonged withering and fermentation.

Quality—See page 24 for a definition of this term.

For the preservation and improvement of this characteristic in a high grown tea, the essential requirements are short withers, hard rolling and short periods of fermentation.

TEA TASTERS' TERMS

Rasping— Akin to 'harsh.'

Row—Same as 'harsh' and 'Rasping.'

Round—See 'full' and 'mellow.'

Smooth—Means more or less the same thing as 'round.' Not so pronounced as a 'full' liquor in colour and strength.

Soft—Teas without point or briskness. Not as poor a term as 'flat,' nevertheless denotes a lack of 'life.' Mainly caused by over-fermenting, and too high a moisture content.

Sour—A sourish taste through bacterial infection. Rarely an inherent character.

The main factors bringing about this characteristic are slow removal of surface moisture from wet leaf and unclean rolling and fermenting conditions.

Stewed—A tea lacking in aroma with an undesirable liquor character, and is due to an excessive loss of essential oils resulting from teas being 'stewed' in the initial stages of firing.

The remedy lies in thinner spreading and quicker firing at a higher exhaust temperature in order to increase the rate of evaporation of water.

Strong—(Strength) See 'body.' Teas with good strength cream down well and need not necessarily be coloury.

Sweaty—A tea with a strange and most unpleasant taste. A taint probably acquired in a similar manner as that described as 'fruity' and 'sour'.

Sweet—A light liquor and not of very good quality.

Tainted—An objectionable flavour. There are several ways in which a taint may be acquired. Some may probably be absorbed by the plant from the soil, whilst others may result from the spraying or dusting of certain insecticides.

As distinct from these chemical taints, those that are produced during the processing of tea mostly arise from bacterial infection. Withering or fermenting being carried out too far under damp, unclean conditions is generally responsible for musty off-flavours, such as 'sour,' 'fruity' and 'sweaty'.

Additional taints may be acquired when tea comes in contact with or is stored in the proximity of odour-bearing materials at any stage in manufacture. Some odour taints may get volatilized in the process of firing but a 'tatty' taint, for example, which results from unwashed hessian may persist.

Tatty—A taint from hessian.

Thick—Denotes a strong liquor.

Thin—The reverse of 'thick.' A tea with little strength. If not the result of an inherent property of the leaf, lack of strength in a liquor is usually due to very hard withers, under-rolling or high rolling temperatures.

Washy—A very thin liquor, lacking in strength.

Weak—Similar to 'washy'.

Weatherly—A term descriptive of a soft character associated with teas made during very wet weather. Attributed to unsatisfactory withering conditions.

CHAPTER 15

FACTORY HYGIENE

Like the preparation of every other food product, it is essential that tea be processed on hygienic lines. Judged by standards of a decade or two ago present day factory operations do turn out cleaner teas. Nevertheless, there is room for improvement and the following suggestions are given for improving hygienic conditions in the manufacture of tea.

Much of the foreign matter that finds its way into tea comes from the floor. It is true that finally the tea is winnowed and picked, and in some cases passed over a belt conveyer and then on to a magnetic extractor. The fact also that firing at high temperatures is itself a sterilizing process has led to a certain amount of neglect in handling the leaf in the earlier stages. However, on hygienic grounds alone, the need for keeping leaf and tea off the floor need hardly be emphasized. To see leaf trodden on by labourers, or swept and collected is revolting.

Quite apart from these considerations, the presence of stones, gravel and sand in the withered leaf charged to rollers increases the wear and tear of roller tables. Besides, the factory floor, particularly in the rolling room, harbours numerous bacteria. The danger of harmful bacterial infection is always present if leaf is not prevented from coming into contact with the floor. Food regulations are becoming more and more stringent and it will not be long before Ceylon must follow the example of other countries by imposing rules in regard to the conditions under which products intended for human consumption are manufactured. The industry must lead and not follow in such respects.

Factory hygiene is not merely a question of eliminating foreign matter from the tea. Machinery receptacles and floors must be kept scrupulously clean. Floors should always be kept in good repair to prevent the accidental inclusion of foreign matter. The rolling room machinery, fermenting tables and floor must be washed daily. All that is necessary is plenty of fresh water. More than a day's accumulation of fluff on ceilings, withering tats and in bulking chambers and all other places in a factory should never be permitted. Receptacles for collecting rubbish and sweepings must be available throughout the factory. All iron work must be protected with paint. And last, but not least, it is essential to ensure that the whole of the factory is brightly and evenly illuminated. If direct sunlight has to be avoided in rolling and fermenting rooms they should be artificially illuminated. Sombre colours for walls should be avoided as far as possible.

The steps to be taken to keep foreign matter out of tea are:—

1. Early replacement of worn-out or damaged plucking baskets, and those used for transporting leaf to the factory.
2. Use of hessian on the floor between banks of tats for the depositing of green leaf and collection of withered leaf.
3. Use of chutes to convey leaf from lofts directly to the rollers.
4. Use of withered leaf sifters.
5. Minimizing the spilling of leaf when charging rollers by correctly designed chutes and hoppers.
6. Use of daily washed hessian below a roller to receive the leaf that is thrown out when it is in operation.

FACTORY HYGIENE

7. Use of trolleys for receiving leaf discharged from rollers.
8. Use of tiled platforms, or trays, for collecting sifted dhool and bulk from roll-breakers.
9. Rejection of all leaf falling on the floor.
10. Raised fermenting tables or fermenting trays.
11. Cooling of fired tea to be done on tables.
12. Avoiding contact between the tea and the floor during the sifting operations.
13. When blowers are used for winnowing the tea, that portion of the floor on which the tea falls should be raised a few inches from the ground. In case of a winnowing machine, the tea should be discharged directly into boxes.
14. Picking over to be done on tables or raised platforms.
15. All boxes for collecting teas to be in good repair, free from splinters and jagged ends.
16. Bulking of tea to be carried out on a special platform, or an adequately large cloth kept scrupulously clean.
17. Use of conveyer belts and magnetic extractors at the time of packing, and
18. Provision at the entrances to a factory for washing or wiping of feet.

APPENDIX A

HYGROMETRIC TABLES

The following two Tables, XXVIII and XXIX, though specially applicable to an elevation of up to about 2,000 feet, may be used at all elevations in problems not requiring precise results, as in air conditioning for withering.

The terms used to describe the wetness of air are *absolute humidity* and *relative humidity*.

(a) **Absolute Humidity**—is the actual moisture content of the air, *i.e.* the amount of water vapour per unit volume of air. It is expressed in Table XXVIII as pounds of water per 100,000 cubic feet of air for a range of 50 to 100°F with differences of 0 to 10° between the wet and dry bulb temperatures.

The pounds of water per 100,000 cubic feet of air are read by following a horizontal line from the dry bulb temperature to the vertical column corresponding to the difference between wet and dry bulbs.

Example—If the readings on a hygrometer show a dry bulb temperature of 75° and a wet bulb temperature of 70°F, the absolute humidity, or moisture content of the air is 105 lb. of water per 100,000 cubic feet of air.

For readings of 75°F (dry) 68°F (wet) it is 94 lb. per 100,000 cubic feet of air, and for 80°F (dry) and 70°F (wet) it is slightly more, being 96 lb.

The table also shows the drying power of air at different temperatures. The maximum amount of water a given volume of air can hold at a certain temperature is indicated by the figure in the first column for 0° difference between wet and dry bulb temperatures. Thus:—

- at 75° it is 135 lb. per 100,000 cubic feet of air.
- at 80° „ „ 158 lb. „ „ „ „ „
- at 100° „ „ 285 lb. „ „ „ „ „

The drying power of air therefore,

- at 75° (dry) 70° (wet) = 135 — 105 = 30 lb. of water per 100,000 cubic feet of air.
- at 75° (dry) 68° (wet) = 135 — 94 = 41 lb. of water per 100,000 cubic feet of air.
- at 80° (dry) 70° (wet) = 158 — 96 = 62 lb. of water per 100,000 cubic feet of air.

These figures indicate only the potential drying capacity of the air at *dry bulb temperature*. In other words, what they serve to show is the amount of water the volume of air can take up at that particular *dry bulb temperature*.

To get the actual evaporative capacity of the air we must take the figure corresponding to saturation at *wet bulb temperature* because saturation is obtained when the dry bulb temperature drops to the wet bulb temperature. In the three examples quoted, we must accordingly take the figure for 70° in the case of air at 75° (dry) 70° (wet), 68° in the case of air at 75° (dry), 68° (wet) and 70° in the case of air at 80° (dry) 70° (wet). From the table, the maximum moisture content for 70° is 115 lb. water per 100,000 cubic feet of air, and for 68°, 108 lb. of water per 100,000 cubic feet of air.

APPENDIX A

The actual evaporative capacity of the air will therefore be :—

- at 75° (dry) 70° (wet) = 115 — 105 = 10 lb.
 at 75° (dry) 68° (wet) = 108 — 94 = 14 lb.
 at 80° (dry) 70° (wet) = 115 — 96 = 19 lb.

Table XXVIII. *Absolute Humidity.*

Dry Bulb °F.	DIFFERENCE										
	between wet and dry bulb temperatures in degrees Fahrenheit.										
	0	1	2	3	4	5	6	7	8	9	10
	Pounds of water per 100,000 feet of air										
50	59	55	51	47	44	40	37	33	30	26	22
51	61	57	53	49	45	41	38	34	31	27	24
52	63	59	55	51	47	43	40	36	33	29	25
53	65	60	57	53	49	45	42	38	34	31	27
54	68	63	59	55	52	48	44	41	37	33	29
55	70	65	62	57	53	50	46	42	38	34	31
56	72	67	63	59	55	51	47	43	40	36	32
57	75	70	66	62	58	54	50	46	42	38	34
58	77	72	68	64	60	55	52	48	43	40	36
59	80	75	71	66	62	58	54	50	46	42	38
60	83	78	74	69	65	61	56	52	48	44	41
61	86	81	77	72	68	63	58	55	50	46	43
62	89	84	80	75	70	66	61	57	53	49	45
63	92	87	83	78	73	68	64	60	55	51	47
64	95	90	86	81	76	71	66	62	57	53	49
65	98	93	88	83	78	74	69	65	60	56	51
66	101	96	91	86	81	76	72	67	62	58	54
67	104	99	94	88	84	79	74	69	64	60	56
68	108	103	97	92	87	82	78	72	68	63	58
69	112	106	101	95	91	85	81	75	71	66	60
70	115	109	104	98	93	89	84	78	74	69	63
71	119	113	107	101	96	92	87	81	76	71	67
72	123	117	112	106	100	95	90	85	80	75	70
73	127	121	116	110	103	98	93	88	83	77	72
74	131	124	119	113	107	102	96	92	86	81	75
75	135	128	123	116	110	105	100	94	89	84	78
76	139	132	126	121	114	108	103	97	92	88	81
77	144	137	131	125	118	112	107	101	95	91	85
78	148	141	135	129	123	117	111	105	99	95	89
79	153	145	139	133	127	121	115	109	103	98	92
80	158	150	144	138	131	125	118	114	107	101	96
81	163	155	148	142	135	129	122	117	111	106	101
82	168	160	153	146	139	133	126	121	114	109	104
83	173	164	157	150	144	138	131	125	119	114	109
84	178	169	162	155	148	142	135	130	123	117	112
85	184	175	167	160	153	147	140	134	127	121	116
86	189	181	174	166	159	151	146	138	132	125	121
87	195	187	179	172	164	158	150	142	136	131	125
88	201	193	185	177	169	163	155	147	141	135	129
89	207	199	190	182	174	168	161	153	147	141	135
90	213	204	196	189	181	173	166	160	153	145	138
91	220	211	202	196	187	180	172	165	158	152	143
92	226	217	208	201	192	185	176	170	163	156	149
93	233	224	214	207	198	191	184	175	168	161	154
94	240	230	221	214	204	197	190	182	175	168	161
95	247	237	230	220	212	203	195	188	180	173	165
96	254	244	236	229	218	211	203	193	185	178	170
97	262	252	244	236	225	217	210	202	191	183	176
98	269	258	250	242	231	223	215	207	199	191	183
99	277	266	258	249	238	230	222	213	205	197	188
100	285	274	265	257	245	237	228	219	211	202	194

(Based on a standard psychrometric chart).

APPENDIX A

(b) **Relative Humidity.**—is the *ratio* of the amount of water held in the air at a certain temperature to the weight of water it can hold at that temperature. This ratio multiplied by 100 gives the *percentage relative humidity* (% R.H.).

From Table XXIX, which shows this ratio, % R.H. can be determined in the same way as absolute humidity is obtained from Table XXVIII, by taking the figure corresponding to a given dry bulb temperature and the difference between wet and dry bulb temperatures.

Table XXIX. *Percentage Relative Humidity.*

Dry Bulb °F.	DIFFERENCE										
	between wet and dry bulb temperatures in degrees Farenheit.										
	0	1	2	3	4	5	6	7	8	9	10
50	100	93	86	80	74	68	62	56	50	44	38
51	100	93	87	80	74	68	62	56	51	45	39
52	100	93	87	81	75	69	63	57	52	46	40
53	100	93	87	81	75	69	64	59	53	47	42
54	100	93	87	81	76	70	65	60	54	48	43
55	100	93	88	82	76	71	65	60	54	49	44
56	100	93	88	82	76	71	65	60	55	50	45
57	100	94	88	83	77	72	66	61	56	51	46
58	100	94	89	83	78	72	67	62	56	52	47
59	100	94	89	83	78	73	67	63	57	53	48
60	100	94	89	83	78	73	67	63	58	53	49
61	100	94	90	84	79	73	68	64	58	54	50
62	100	94	90	84	79	74	69	64	59	55	51
63	100	95	90	85	79	74	70	65	60	55	51
64	100	95	90	85	80	75	70	65	60	56	52
65	100	95	90	85	80	75	70	66	61	57	52
66	100	95	90	85	80	75	71	66	61	57	53
67	100	95	90	85	81	76	71	66	62	58	54
68	100	95	90	85	81	76	72	67	63	58	54
69	100	95	90	85	81	76	72	67	63	59	54
70	100	95	90	85	81	77	73	68	64	60	55
71	100	95	90	85	81	77	73	68	64	60	56
72	100	95	91	86	81	77	73	69	65	61	57
73	100	95	91	86	82	77	73	69	65	61	57
74	100	95	91	86	82	78	73	70	66	62	57
75	100	95	91	86	82	78	74	70	66	62	58
76	100	95	91	87	82	78	74	70	66	63	58
77	100	95	91	87	82	78	74	70	66	63	59
78	100	95	91	87	83	79	75	71	67	64	60
79	100	95	91	87	83	79	75	71	67	64	60
80	100	95	91	87	83	79	75	72	68	64	61
81	100	95	91	87	83	79	75	72	68	65	62
82	100	95	91	87	83	79	75	72	68	65	62
83	100	95	91	87	83	80	78	72	69	66	63
84	100	95	91	87	83	80	76	73	69	66	63
85	100	95	91	87	83	80	76	73	69	66	63
86	100	96	92	88	84	80	77	73	70	66	64
87	100	96	92	88	84	81	77	73	70	67	64
88	100	96	92	88	84	81	77	73	70	67	64
89	100	96	92	88	84	81	78	74	71	68	65
90	100	96	92	89	85	81	78	75	72	68	65
91	100	96	92	89	85	82	78	75	72	69	65
92	100	96	92	89	85	82	78	75	72	69	66
93	100	96	92	89	85	82	79	75	72	69	66
94	100	96	92	89	85	82	79	76	73	70	67
95	100	96	93	89	86	82	79	76	73	70	67
96	100	96	93	90	86	83	80	76	73	70	67
97	100	96	93	90	86	83	80	77	73	70	67
98	100	96	93	90	86	83	80	77	74	71	68
99	100	96	93	90	86	83	80	77	74	71	68
100	100	96	93	90	86	83	80	77	74	71	68

(Based on a standard psychrometric chart).

APPENDIX A

Example—

at 75° (dry) 70° (wet) — difference 5 — % R.H. is 78.

at 75° (dry) 68° (wet) — „ 7 — % R.H. is 70.

at 80° (dry) 70° (wet) — „ 10 — % R.H. is 61.

It will be noted that at all temperatures % R.H. is 100 if the hygrometric difference is 0, which means that the air is completely saturated and can absorb no more moisture.

What % R.H. indicates is only the degree of wetness of the air and not its evaporative capacity. Thus 50% R.H. means that the air is 50% wet, and 100% R.H. that the air is 100% wet. Absolutely dry air will have 0% R.H.

Use of the Tables—One use to which these tables can be put is to compare the evaporative capacity of air at some particular % R.H. For example, a 73% R.H. at 60° (dry) is not the same as a 73% R.H. at say 86° (dry). Let us examine these separately.

Air at 73% R.H. and 60° (dry)—From Table XXIX this corresponds to a difference of 5° between wet and dry bulb temperatures or a wet bulb temperature of 55°. From Table XXVIII moisture content of air at 60° (dry) 55° (wet) is 61 lb. and the maximum amount of water this air can absorb is that amount at 55°. On referring to the first column for 0° difference between wet and dry bulb temperatures, the figure against 55° is 70 lb. The actual evaporative capacity is therefore equal to 70—61 which is 9 lb. per 100,000 cubic feet of air.

Air at 73% R.H. and 86° (dry)—Proceeding on the foregoing lines, it will be seen that the wet bulb temperature is 79° the moisture content 138 lb. and saturation moisture content at 72°, 153 lb. The air in this case will have an evaporative capacity of 153—138 or 15 lb.; more than one and a half times that in the last example.

This illustration has been given in view of the commonly adopted practice of basing the drying power of air entirely on the figure for % R.H. without considering the temperatures that are involved.

The hygrometric difference, however, irrespective of the dry bulb temperature is a more accurate basis for judging the evaporative capacity of air, the bigger the difference the greater the evaporative capacity.

Examples (from Table XXVIII):—

Dry bulb °F	Wet bulb °F	Hygrometric difference °F	Saturation moisture content at <i>wet bulb</i> lb.	Moisture content of air lb.	Evaporative capacity lb.
75	75	0	135	135	0
75	74	1	131	128	3
75	73	2	127	123	4
75	72	3	123	116	7
75	71	4	119	110	9
75	70	5	115	105	10
75	69	6	112	100	12
75	68	7	108	94	14
75	67	8	104	89	15
75	66	9	101	84	17
75	65	10	98	78	20

Note—The evaporative capacity of air with a 10° hygrometric difference is twice that of air showing a difference of 5° between wet and dry bulb temperatures.

APPENDIX A

The evaporative capacity of air with the *same hygrometric difference* is, to all intents and purposes, the same at all temperatures within the range 50 to 100°. Taking a few examples from Table XXVIII again we get the following:—

Dry bulb °F	Wet bulb °F	Hygrometric difference °F	Saturation moisture content at <i>wet bulb</i> lb.	Moisture content of air lb.	Evaporative capacity lb.
60 100	50 90	10 10	59 213	41 194	18 19
70 100	65 95	5 5	98 247	89 237	9 10
58 82	50 74	8 8	59 131	43 114	16 17

Many planters may also find it useful to know, when using heated air for withering with the aid of hot air from a drier *not* being used for firing tea, to what temperature air must be raised to get a certain hygrometric difference or they may like to know what hygrometric difference will be obtained if air is raised to a certain temperature. The use of Table XXVIII again will give the approximate answers to these two questions. Assume temperature of outside air is 62° (dry) 60° (wet).

(1) If a hygrometric difference of 8° is required to what temperature must air in the bulking chamber be raised?

Air at 62° (dry) 60° (wet) has a water content of 80 lb. Refer to the column for a 8° hygrometric difference and note the dry bulb temperature that corresponds to 80 lb. This will be found to be 72°, which is the temperature the air will have to be raised to in order to give a 8° hygrometric difference.

(2) If the same air is raised to 75°, what will be the hygrometric difference? Against 75° in the horizontal line it will be found that the nearest figure to 80 lb. (the water content of the air) is 78, which is in the column for a 10° hygrometric difference. The air if raised to 75°, can therefore be expected to show a difference of 10° between wet and dry bulb temperatures.

If raised to 66°, the nearest figure from the Table is 81 and this lies in the column for a 4° hygrometric difference. The heated air in this case will therefore have a final temperature of 66° (dry) 62° (wet).

If raised to more than 75°, the hygrometric difference will be greater than 10°.

APPENDIX B

RELATIONSHIP BETWEEN OUTTURNS

This is determined by the formula:

$$a = \frac{b \times 100}{c},$$

where *a* is percentage outturn of withered leaf to green leaf or *percentage wither*.

b is percentage outturn of made tea to green leaf.

c is percentage outturn of made tea to withered leaf.

For example, suppose a 44% outturn of made tea to withered leaf is aimed at and green leaf is dry (say 24% made tea outturn to green leaf) a 55% wither will have to be taken. If leaf is very wet giving only an 18% outturn a 41% wither should be taken to get the same degree of wither. It is understood that no deductions are made for surface water.

Table XXX has been drawn up based on the formula given above and covers the range of 17 to 28% outturn made tea to green leaf, and a range of 40 to 50% outturn made tea to withered leaf. It shows the wide variation in the percentage of wither under different conditions and the figures given will provide a suitable check on calculations involving outturns.

Method of using the Table—(Some examples are given below):—

(a) To determine percentage outturn of made tea to withered leaf for a percentage wither of 50, and an outturn of made tea to green leaf of 22%. Read the figure under column for 22 percentage outturn made tea to green leaf which corresponds to a 50% wither. This will be 44. If the percentage wither is 55 the figure will be 40. If the percentage wither is more than 55, the leaf would be under-withered.

(b) *Very wet leaf*—(17% outturn):—For a percentage wither of 43, the outturn of made tea to withered leaf is 40. For a percentage wither of more than 43, the leaf would be under-withered.

(c) *Dry leaf*—(24% outturn):—For a percentage wither of 55, the outturn of made tea to withered leaf is 44. If the former is more than 60, the leaf would be under-withered, and if less than 48, over-withered.

(d) *Very dry leaf*—(28% outturn):—A 56% wither would give a hard wither (50% outturn), and it may be of interest to note that a percentage wither as high as 70% may be taken without the risk of the leaf being under-withered.

APPENDIX B

Table XXX Relationship between outturns.

Percentage wither	PERCENTAGE OUTTURN OF MADE TEA TO GREEN LEAF											
	17	18	19	20	21	22	23	24	25	26	27	28
	PERCENTAGE OUTTURN OF MADE TEA TO WITHERED LEAF											
34	50											
35	49											
36	48	50										
37	46	49										
38	45	47	50									
39	44	46	49									
40	43	45	48	50								
41	42	44	46	49								
42	41	43	45	48	50							
43	40	42	44	47	49							
44		41	43	45	48	50						
45		40	42	44	47	49						
46			41	43	46	48	50					
47			40	43	45	47	49					
48			40	42	44	46	48	50				
49				41	43	45	47	49				
50				40	42	44	46	48	50			
51					41	43	45	47	49			
52					40	42	44	46	48	50		
53					40	42	43	45	47	49		
54						41	43	44	46	48	50	
55						40	42	44	45	47	49	
56							41	43	44	46	48	50
57							40	42	44	46	47	49
58								41	43	45	47	48
59								41	42	44	46	47
60								40	42	43	45	47
61									41	43	44	46
62									40	42	44	45
63									40	41	43	44
64										41	42	44
65										40	42	43
66											41	42
67											40	42
68											40	41
69												41
70												40

Note:—Figures in *Italics* denote percentage outturn of made tea to withered leaf.

Table XXXI. *Heat developed in rollers under different conditions.*

Situation of factory	Type of rolling	No. of roll	Pressure application	Period of rolling	Dhool outturn %	Rolling room temperature °F.	Temperature of leaf at end of rolling period °F.	Rise in temperature °F.
Low-country	Light	1	Nil	25 mins	7	79	90	11
		2	5 on 5 off	"	18	79	94	15
		3	" "	"	19	81	95	14
"	"	5	5 on 5 off	30 mins	—	78	90	12
		6	" "	"	—	80	95	15
"	"	5	Continuous	20 mins	—	86	98	12
Mid-country	Very light	1	5 on 5 off	30 mins	2	71	82	11
		2	" "	"	5	71	83	12
		3	" "	"	16	72	84	12
		4	" "	"	15	73	86	13
		5	" "	"	14	73	83	10
					(48% B.B.)			
"	"	1	Nil	40 mins	—	72	80	8
		2	Nil	30 mins	—	72	78	6
"	Somewhat heavy	1	5 on 5 off	40 mins	—	72	87	15
		2	" "	30 mins	—	72	84	12
Up-country	Heavy	1	5 on 5 off	30 mins	15	65	85	20
		2	" "	"	21	65	88	23
		3	" "	"	20	65	89	24

Table XXXI contd.—Heat developed in rollers under different conditions.

Situation of factory	Type of rolling	No. of roll	Pressure application	Period of rolling	Dhool outturn %	Rolling room temperature °F.	Temperature of leaf at end of rolling period °F.	Rise in temperature °F.
Up-country	Light	1	5 on 5 off	30 mins	8	71	80	9
		2	" "	"	9	70	81	11
		3	" "	"	16	70	83	13
		4	" "	"	15	70	84	14
		5	" "	"	16 (36% B.B.)	70	84	14
"	"	1	Continuous	45 mins	5	65	82	17
"	Very heavy	3	5 on 5 off	25 mins	23	68	92	24
		4	" "	"	33 (11% B.B.)	68	98	30
"	Heavy	1	8 on 2 off	30 mins	—	53	70	17
"	"	2	3 on 2 off	35 mins	—	49	77	28
"	More dhool in early rolls	1	8 on 2 off	30 mins	26	66	83	17
		2	4 " 1 "	"	23	66	83	17
		3	" "	"	20	66	85	19
		4	" "	"	17	66	84	18
		5	3 on 2 off	25 mins	9 (5% B.B.)	66	82	16
"	Harder rolling in early rolls	1	8 on 2 off	30 mins	35	67	81	14
		2	4 " 1 "	"	26	67	82	15
		3	" "	"	17	68	84	16
		4	" "	"	16 (6% B.B.)	68	82	14

NOTE:—Roll-breaker mesh—low-country No. 4 or thereabouts,
mid-country No. 5 "
up-country No. 6 "
"

APPENDIX C

Table XXXII. *Effect of degree of wither on temperature rise (Low-country factory).*

Roll	Rolling room temperature	TEMPERATURE OF LEAF AT END OF ROLLING PERIOD		RISE IN TEMPERATURE	
		Hard wither	Soft wither	Hard wither	Soft wither
1st	81°F	89°F	89°F	8°F	8°F
2nd	81°F	96°F	90°F	15°F	9°F
3rd	77°F	97°F	91°F	20°F	14°F

Table XXXIII. *Comparison between two methods of pressure application in relation to rise of temperature of leaf. (Up-country factory)*

Note:—Pressures adjusted to give the same dhool outturn.

	5 mins. on 5 off	15 mins. on 5 off
(a) 2nd rolls—40 mins.—25% dhool		
Rolling room temperature	63°F	65°F
Temperature of leaf fed into roller	74°F	74°F
Temperature of leaf after 15 minutes of rolling	81°F	82°F
At end of rolling (40 mins.)	84°F	86°F
Final rise in temperature	21°F	21°F
(b) 3rd rolls—20 mins.—15% dhool		
Rolling room temperature	66°F	68°F
Temperature of leaf fed into roller	76°F	77°F
Temperature of leaf at end of rolling	82°F	86°F
Final rise in temperature	16°F	18°F

APPENDIX C

Table XXXIV. *Effect of three methods of rolling on rise of temperature of leaf.*
(Up-country factory).

Method of rolling	No. of roll	Dhool outturn %	Rolling room temperature °F	Temperature of leaf at end of rolling period °F	Rise in temperature °F
(a) Epicyclic pressure (no pressure cap)	1	20	67	90	23
	2	32	67	91	24
	3	38 (10% B.B.)	68	91	23
(b) Battens pressure cap (5 on 5 off)	1	13	67	92	25
	2	16	67	90	23
	3	25	68	92	24
	4	35 (11% B.B.)	69	98	29
(c) Battens pressure cap (continuous pressure)	1	13	66	91	25
	2	16	66	90	24
	3	25	66	95	29
	4	35 (11% B.B.)	67	100	33

Note:—Each roll of 25 minutes duration, and pressures adjusted in (b) and (c) to give equal dhool outturns.

APPENDIX D

TEMPERATURES OF DHOOL

Table XXXV *Effect of roll-breaking on temperature of leaf.*
(A few observations)

Rolling room temperature °F	Temperature of leaf at end of rolling period °F	Temperature of leaf after roll-breaking °F	Cooling effect °F
46	75	63	12
46	77	58	19
61	88	68	20
62	83	70	13
63	87	71	16
67	93	75	18
69	88	76	12
69	90	74	16
70	92	76	16

APPENDIX E

THE KEEGEL CONE

Table XXXVI. *Dimensions of 45° cones recommended for full range of rollers in general use*

<i>Roller</i>	<i>Cone</i>	
	<i>Base</i>	<i>Height</i>
28" C. C. C.	4"	2"
28" Walkers	5½"	2¾"
32" "	6½"	3¼"
34" C. C. C.	7"	3½"
34" Davidsons	8"	4"
35" Walkers	8"	4"
36" Marshalls	9"	4½"
40" C. C. C.	10"	5"
40" Walkers	10½"	5¼"
44" C. C. C. and Davidsons	12"	6"
45" Walkers	13"	6½"
45.5" C. C. C.	12"	6"
46.5" Walkers	11½"	5¾"
46.6" Davidsons	13"	6½"
47" C. C. C.	12½"	6¼"

- NOTE.**—1. The sides of the cone should be straight.
2. The base should be flush with the table. There should be no projecting edges.
3. The apex should be slightly rounded off. The vertical height of the cone from table level will therefore be slightly less than the figures given above.

APPENDIX E

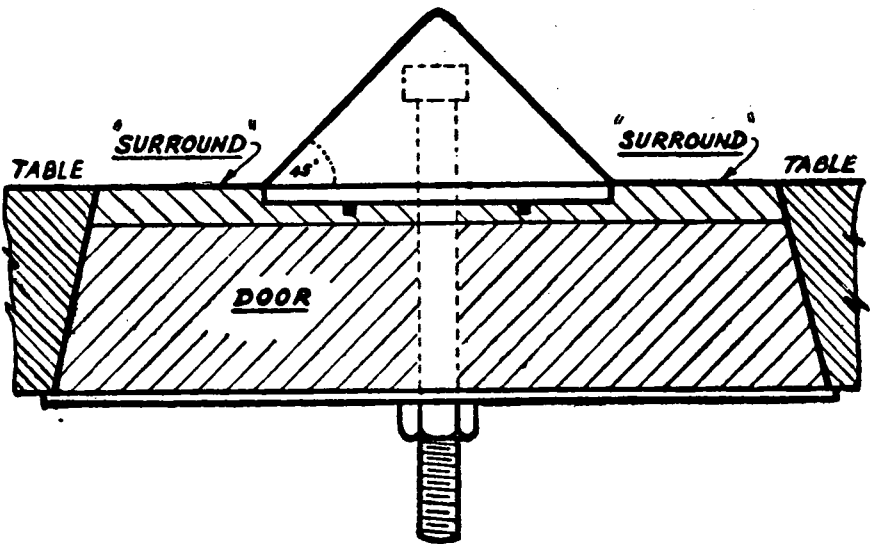

FIG. 22. The Keegel Cone

APPENDIX F

BOILING POINT OF WATER AT DIFFERENT ELEVATIONS

Table XXXVII. *Effect of altitude on boiling point of water*

Elevation feet	°F
Sea level	212
521	211
1,044	210
1,569	209
2,096	208
2,625	207
3,156	206
3,689	205
4,224	204
4,761	203
5,300	202
5,841	201
6,384	200
6,929	199
7,476	198

(Source:—Kempe's Engineering Year-book).

1.—WITHERING

Date.....

No. of Weighing	Condition of leaf (Wet or Dry)	Time spread	ARTIFICIAL						NATURAL					
			Time fans worked			Loft temperature		Outside temperature at the time		TIME			Outside temperature at the time	
			On	Off	Period	Dry	Wet	Dry	Wet	From	To	Period	Dry	Wet

Weight of green leaf —No. 1 weighing lb.
 No. 2 " lb.
 No. 3 " lb.
 Total for day lb.
 Total weight of withered leaf for the day lb.

NOTE.—For period of wither of each batch of leaf see under "Rolling".

2.—ROLLING

Date.....

Batch No.	Time rolling started (each batch)	Period of wither (each batch)	Weight of withered leaf charged (each batch)	DHOOLS					Big Bulk	Loss in rolling	Time fed to drier (each batch)	Period of fermentation (each batch)	Hygrometer readings (rolling room)	
				1	2	3	4	5					dry	wet

NOTE.—Columns for rollers are omitted because it is taken for granted that manufacture is organized and carried out according to a fixed plan.

3.—FIRING

Date.....

A.

Drier No.	LIGHTING UP			Amount of fuel used	FIRING			Amount of fuel used
	Time				Time			
	from	to	period		from	to	period	
1								
2								
3								

Total amount of fuel used for day.....

B.

Batch No.	MADE TEA				Percentage outturn M.T. to W.L.	Wt. of blow-out after re-firing at end of day
	dhools	addappu dhool	big-bulk	Total		

Total weight of fired tea (inclusive of blow-out) for day.....lb.

5.—GRADING

Month.....

Date	Total wt. of made tea* (addappu, blow-out inclusive)	GRADES						Total wt. of grades (crop)		Weight of refuse tea discarded	Gain in weight during sifting	
		B. O. P.		etc.	B. M.		daily	to-date	weight		%	
		weight	%		weight	%						
1												
2												
3												
etc.												
31												
TOTAL												

*See figure for made tea in record sheet No. 4.

6.—BIN CARD

Month.....

Grade.....

Date	IN		Out for final firing and/or packing	Balance in bin	Weight packed		Loss in final firing and/or packing		Surplus in	Balance in stock	Excess registered on checking
	daily	to-date			daily	to-date	daily	to-date			
Brought forward		3,000								3,000	
1	676	3,676	2,676	1,000	2,000	2,000	20	20	656	1,656	
2	500	4,176	—	2,156	—	2,000	—	20	—	2,156	
3	1,300	5,476	—	3,456	—	2,000	—	20	—	3,456	
4	750	6,226	3,100	1,106	3,000	5,000	10	30	90	1,196	
etc.											
31											
TOTAL		18,500				15,000		75		3,425	100

Carried over for following month' 3,525

NOTE.—The figures given above are purely hypothetical.
 *Balance in stock' is 'balance in bin' plus any surplus tea after packing.
 *Balance in bin' is the sum of 'balance in stock' and the amount put in daily less figure in column 4 (amount taken out).

BIBLIOGRAPHY

TEA QUARTERLY—The following list consists of all articles which have appeared in the *Tea Quarterly* up to Volume XXVII. They are arranged under different headings for easy reference:—

Subject	Author	Title	Year	Volume	Part	Page
AIR CONDI- TIONING	Evans, D.I.	Air conditioning and some of the principles involved	1929	II	3	89
			1929	II	4	115
	Lamb, J.	Air conditioning in tea factories	1938	XI	3	151
CROP PROTEC- TION	Lamb, J.	Sulphur taints	1935	VIII	4	187
	Lamb, J.	Copper residues in relation to quality	1950	XXI	4	33
	Keegel, E.L.	The effect of spray residues on the quality of manufactured tea	1952	XXIII	1	2
DIRECT-FIRED HEATERS	Shell Co. of Ceylon Ltd.	A new type of direct-fired air heater for drying of tea	1940	XIII	2	73
			1946/47	XVIII	2	41
DRIERS	Evans, D.I.	A short note on suction driers	1932	V	2	69
	Lamb, J.	Test of a Marshall's new Empire tea drier	1935	VIII	1	65
	Lamb, J.	Notes on drier temperatures	1938	XI	2	89
	Finley, D.W.	A note on the life of drier tubes	1940	XIII	2	78
	Keegel, E.L.	A note on drier capacities	1954	XXV	1	21
	FERMENTA- TION	Evans, D.I.	Tea Fermentation	1930	III	1
1930				III	2	49
1930				III	3	76
1930				III	4	116
1931				IV	1 & 2	2
Francillon, F.R.		Notes on green leaf sifting and fermentation	1935	VIII	4	192
Keegel, E.L.		Fermentation in relation to heat developed in rolling	1955	XXVI	3	96
FIRING		Lamb, J.	The theory and practice of tea drying	1935	VIII	1
	Lamb, J.	Studies on the firing of tea	1939	XII	4	171
			1940	XIII	4	156
			1942	XV	1	5
			1942	XV	1	13

BIBLIOGRAPHY

Subject	Author	Title	Year	Volume	Part	Page	
FIRING —(<i>contd.</i>)	Ridler, W. F. A.	Steam heating of air for tea drying machines	1941	XIV	2	40	
FUELS	Lamb, J	Studies on fuels for tea driers Part 1	1936	IX	1	17	
		Part 2	1936	IX	2	48	
		Part 4	1936	IX	4	163	
	Shell Co. of Ceylon, Ltd.	Studies on fuels for tea driers Part 3	1936	IX	3	111	
		Part 5	1936	IX	4	177	
		Chapman, E. H. B.	Coal for tea firing	1936	IX	2	55
GRADING	Finley, D.W. Lamb, J.	Winnowing of tea	1936	IX	3	123	
		Grading tea with stamped aluminium sieves Part 1	1937	X	4	191	
		Part 2	1939	XII	4	179	
			Part 3	1940	XIII	2	82
		Keegel, E.L.	Investigations into the methods of increasing the outturn of the fannings grade	1950	XXI	2 & 3	5
		Keegel, E.L. and Gunaratnam, S. M.	Interim report on the performance of the 'Shizuoka' electric separator	1956	XXVII	1 & 2	42
MANUFACTURE (in general)	Whitehead, F. J.	Modern tea manu- facture—Ceylon Research Insti- tute Factory	1929	II	2	38	
	Evans, D.I.	Some problems of tea manufacture	1929	II	2	44	
	Evans, D.I.	Factors in tea manufacture	1931	IV	1 & 2	54	
	Sastri, B.N.	Some aspects of tea manufacture	1931	IV	3 & 4	124	
	Evans, D.I.	A short note on factories and tea manufacture	1932	V	2	62	
	Evans, D.I.	Certain aspects of tea manufacture	1933	VI	1	37	
	Gadd, C.H.	Factory experi- mentation	1933	VI	2	59	
	Palmer, W.A.	Some notes on experimental manufacture of medium grown leaf at a higher elevation	1934	VII	4	171	
	Lamb, J.	Research and the practical manu- facture of tea	1937	X	1	56	
	Norris, R.V.	Some manufactur- ing problems	1939	XII	2	55	

BIBLIOGRAPHY

Subject	Author	Title	Year	Volume	Part	Page	
MANUFACTURE (in general) (<i>contd</i>)	Finley, D. W.	Heat in relation to manufacturing processes	1939	XII	2	62	
	Lamb, J.	A review of tea manufacture in 1941	1941	XVI	2	65	
	Lamb, J.	Tea Manufacture	1946-47	XVIII	3	74	
	Lamb, J.	Tea Manufacture	1947	XIX	2	69	
	Lamb, J.	Tea Manufacture	1949	XX	1	24	
	Keegel, E. L.	Common problems in tea manufacture	1951	XXII	1	20	
	Keegel, E. L.	Relation of coarse plucking to quality of made tea	1951	XXII	3	112	
	Keegel, E. L.	The principles of tea manufacture	1953	XXIV	1 & 2	23	
	Keegel, E. L.	Preservation of quality	1955	XXVI	1 & 2	56	
	Keegel, E. L.	The outturn of made tea to green leaf	1955	XXVI	4	138	
	Keegel, E. L.	Miscellaneous notes on manufacture	1956	XXVII	1 & 2	20	
	MARKET REQUIREMENTS	Horne, R. H.	Market requirements	1933	VI	2	63
		Meares, C. H.	Does the future of Ceylon tea depend on fine liquors and infusions or on showy, hard, black twisted tea?	1937	X	2	123
		Horne, R. H.	Tea standards	1949	XX	1	30
		Kane, T.	The future of Ceylon tea	1955	XXVI	1 & 2	63
MISCELLANEOUS		Ridler, W. F. A.	The use steam in tea factories	1935	VIII	3	147
	Stromgren, S.	On measurement of temperature in gases	1937	X	2	129	
	Lamb, J.	Machines & materials—a summary of tests carried out at St. Coombs factory	1938	XI	3	154	
	Lamb, J.	Tea in relation to food and drug regulation—ash contents	1941	XIV	3	110	
	MOISTURE IN TEA	Evans, D. I.	The moisture content of made tea	1932	V	2	54
Evans, D. I.		A simple apparatus for the determination of moisture in tea	1932	V	2	59	
Lamb, J.		The storage and packing of tea	1935	VIII	4	171	
Lamb, J.		A note on the packing of forward samples of tea	1938	XI	3	159	
Keegel, E. L.		The Kaybee infra-red moisture tester (Type X-14)	1954	XXV	4	93	

BIBLIOGRAPHY

Subject	Author	Title	Year	Volume	Part	Page
ORGANIZATION	Newton, G. K.	Tea factory organization and management	1936	IX	4	199
	Whitehead, F. J.	Factory Organization	1937	X	1	70
	Newton, G. K.	The importance of teafactory organization	1952	XXIII	3	90
PACKING	Lamb, J.	A note on packing materials	1937	X	2	126
	Lamb, J.	Questions regarding the local supply of tea chests and firewood for estates	1941	XIV	3	113
ROLLING	Norris, R. V.	Cooled rollers	1931	IV	3 & 4	88
	Norris, R. V.	Tea machinery—Mckercher C.T.C. roler	1932	V	1	27
	Lamb, J.	Studies on the rolling of tea	1938	XI	3	131
	Norris R. V.	Further tests with the Clivemeare roller	1939	XII	3	147
	Lamb, J.	A review of rolling methods in tea manufacture	1946-47	XVIII	1	19
	Lamb, J.	Tea Tasters' Terms	1934	VII	3	129
	Bradshaw, R. G. and Yuille, H. B.	A glossary of tea tasters' terms	1935	VIII	4	183
VEGETATIVE PROPAGATION	Lamb, J.	A note on the manufacture of leaf from selected individual bushes	1939	XII	4	183
	Keegel, E. L.	Vegetative propagation of tea—the manufacturing aspect	1953	XXIV	4	82
	Landreth, J.	A miniature roller for clonal experiments	1954	XXV	3	66
	Keegel, E. L.	A note on the operation of the miniature roller	1954	XXV	3	66
	Evans D. I.	Chemical wither	1928	I	4	93
WITHERING	Stromgren S.	On the theory of water evaporation and its application to the withering and drying of tea	1933	VI	2	67
		Part 2	1933	VI	3	104
	Hall, A.H. & Glen Dickson, T.	A cold withering experiment	1934	VII	3	118
	Stromgren, S.	Characteristics of propeller fans	1936	IX	2	80
	Webber, C. R.	Quick withering	1951	XXII	1	18
	Keegel, E. L.	Withering by heated air	1954	XXV	4	87

BIBLIOGRAPHY

T.R.I. BULLETINS:—

				<i>Pages</i>
No. 2	Annual report of the Biochemist for 1927	18-24
No. 3	do. 1928	28-37
No. 4	do. 1929	20-28
No. 5	do. 1930	30-39
No. 7	Handbook concerning tea manufacture at St. Coombs— D. I. Evans	
No. 8	Annual report of the Biochemist for 1931	44-47
No. 9	Tea manufacture in Ceylon—D. J. Evans	
No. 10	Annual report of the Biochemist for 1932	48-60
No. 11	do. Agricultural Chemist for 1933	53-64
No. 12	do. Tea Technologist for 1934	51-61
No. 13	do. do. for 1935	58-72
No. 17	do. do. for 1936	60-86
No. 18	do. do. for 1937	63-83
No. 19	do. Biochemical Dept. for 1938	65-75
No. 21	do. Biochemist for 1939	63-69
No. 22	do. do. for 1940	73-76
No. 23	do. do. for 1941	69-74
No. 24	do. Biochemical Dept. for 1942	48-52
No. 25	do. Biochemist for 1943	52-58
No. 26	do. do. for 1944	53-62
No. 27	do. do. for 1945	46-49
No. 28	do. do. for 1946	50-56
No. 29	do. do. for 1947	45-55
No. 30	do. do. for 1948	50-62
No. 31	do. Chemical Division for 1949	29-31
No. 32	do. do. for 1950	25-35
No. 33	do. do. for 1951	27-32
No. 34	do. do. for 1952	24-30
No. 35	do. do. for 1953	33-36
No. 36	do. Technologist for 1954	33-37
No. 37	do. do. for 1955	33-39
No. 38	do. do. for 1956	34-38

INDEX TO TABLES, FIGURES, DIAGRAMS AND PLATES

TABLES	PAGE
I. Changes in solubility of oxidizable matter ...	11
II. Percentage solubility of dry matter ...	11
III. Pectins in tea leaf ...	12
IV. Values of catechins and caffeine ...	21
V. Percentage composition of plucked leaf ...	22
VI. Relationship between moisture in green leaf and withered leaf ...	29
VII. Effect of condition of green leaf on percentage wither ...	30
VIII. Percentage wither required to give same degree of wither ...	30
IX. Relationship between outturn of made tea to withered leaf and type of wither ...	31
X. Rate of withering of the main parts of a shoot ...	32
XI. Fan requirements ...	38
XII. Area of fan inlet ...	40
XIII. Optimum charges for standard rollers ...	52
XIV. Roller pressures at table level ...	53
XV. Intake of a roll-breaker ...	76
XVI. Temperature changes in leaf after rolling ...	83
XVII. Rate of spread for various thicknesses ...	84
XVIII. Relationship between temperature of firing, load and period of drying ...	90
XIX. Effect of wither on output of a drier... ..	97
XX. Equivalents of stamped aluminium to brass weave	106
XXI. Gain in moisture during sifting and picking ...	110
XXII. Effect of wither on intake of a drier ...	117
XXIII. Effect of a very soft wither on period of fermentation ...	118
XXIV. Shortening of fermentation by reducing batch weight ...	119
XXV. Relationship between charging interval and initial charge ...	120
XXVI. Relationship between rolling period and charging interval ...	121
XXVII. Relationship between rolling period and charging interval ...	121
XXVIII. Absolute humidity ...	141
XXIX. Percentage relative humidity ...	142
XXX. Relationship between outturns ...	146
XXXI. Heat developed in rollers under different conditions ...	147
XXXII. Effect of degree of wither on temperature rise ...	149
XXXIII. Comparison between two methods of pressure application in relation to rise of temperature of leaf ...	149
XXXIV. Effect of three methods of rolling on rise of temperature of leaf ...	150
XXXV. Effect of roll-breaking on temperature of leaf ...	151
XXXVI. The 'Keegel' cone ...	152
XXXVII. Effect of altitude on boiling point of water ...	154

INDEX

FIGURES	PAGE
1 Section of early type of roller table	43
2 Jacksons' battens	43
3 Reeves' roller table	43
4 The Semi-cone	43
5 The Domed cone	43
6 The Rettie cone	44
7 The Beehive cone	44
8 The Plain cone	44
9 Cylindrical epicyclic-pressure fitting	45
10 A suitable E.P. fitting for first rolls	47
11 Small cylindrical projection on roller door	48
12 Octagonal arrangement on roller table	60
13 Octagonal arrangement on roller table	60
14 Under-side of a pressure cap with small battens	61
15 Type of batten fixed to under-side of a pressure cap	61
16 Concave shaped pressure cap	61
17 Arrangement of a plain pressure cap and a plain cone	61
18 Graph indicating development of colour and quality... .. .	77
19 Drying curve for an exhaust temperature of 120—130°F	88
20 Drying curve for an exhaust temperature of about 110°F	91
21 Drying curve for an exhaust temperature of about 140°F	91
22 The Keegel cone	153

DIAGRAMS

1 A well arranged rolling programme	124
2 A rolling programme using two roll breakers	125
3 A badly arranged rolling programme	126
4 Roller time tables	127

PLATES

	PAGE
I. The fermentation process diagrammatically represented <i>facing</i>	11
II. Roller table with M & S battens and fadeaway cone <i>facing</i>	62
III. Roller table with Crescent battens and fadeaway cone <i>facing</i>	62
IV. Sample record of inlet and exhaust temperatures <i>facing</i>	92

SUBJECT INDEX

- Absorption of moisture, *see* Moisture
- Air, conditioning of, 35-36, 39-41, 64-65, 108
drying capacity of, 26, 35, 140-144
hygrometric properties of, 26, 140-144
volume of, in firing, 88
volume of, in withering, 38
- Altitude and manufacture, 19, 20, 21, 31, 49, 50, 56, 57, 58, 59, 64, 70,
73, 74, 88, 99, 102, 108, 119
- Aluminium for fermenting, 84
stamped for sifting, 105-106
- Appearance, 18, 24, 31, 57, 63, 104-105, 106-107, 130
effect of rolling on, 42, 45, 46, 47, 57-58, 63-64
effect of type of leaf on, 20, 49-50, 73
effect of wither on, 31
- Aroma, 14, 85
- Aromatic constituents, 14
- Artificial withering, *see* Withering
- Astringency, 8, 10, 17 *see also* Pungency
- Bacteria, 17, 33, 84
- Bakey teas, 93
- Banji, 21, 34
- Battens, 42-43, 60
- Batten Pressure cap rolling, 42
- Big bulk, 43, 58, 63, 67, 75, 105
firing of, 89, 90
- Bins, 113-114
- Blackness of teas, 49, 130
- Blister blight, 33
- Blowers, *see* Wincwing of teas
- Blow out, 110-111
- Body, *see* Strength
- Boiling point of water, 154
- Boosting system in withering, 37 *et seq*

INDEX

- Brass weave, for sifting, 105-106
- Briskness, 131, *see also* Soft liquors
- Broken grades, description of, 102-103
- Broken mixed, description of, 104
- Brownish teas, 51, 130
- Bruising of leaf, 24, 32, 41
- Buds, 20, 32, 62, 129
- Burners, liquid fuel, 95
- Caffeine, 12, 21
- Cash-hardening, 86, 92, 112, 131
- Catechins, 8, *see also* Tannings,
- Cells of leaf, 7, 28, 42, 77, 79
- Cell sap, 9, 42, 131
- Characteristics of tea, 19, 24, 129 *et seq*
- Charges, roller, 52, 118 *et seq*
- Charging, interval, 59, 80, 119
- Chemical changes, 7 *et seq*
 during fermentation, 10-11, 12-14, 14-15
 during rolling, 10
 during withering, 9, 28
- Chemical compounds, 7, 10, 17
 oxidation of, 8
- Chests, 115
- Chest linings, 114-115
- Chlorophyll, 14-15
- Circulation of air, in lofts, 37, 38, 41
 in rolling room, 64-66
 in sifting room, 108
- Coal, -95-96
- Coarse leaf, 22, 31, 33, 41, 50, 79, 104, 105, 130
- Coarse liquors, 52

INDEX

- Colour, 24, 34, 59, 130
 effect of period of fermentation on, 77, 85
- Condensation compounds. 8, 9, 10, 11
- Cones, 43-44, 60, 61
- Constituents of tea leaf, 7 *et seq*
 aromatic, 14
 caffeine, 12
 enzymes, 7, 9
 oxidizable matter, 7, 9, 10
 pectins, 12, 14
- Continuous rolling, 67 *et seq*
- Costs, firing, 96
- Creaming, 12, 131
- Cutters, 107
- Damage to leaf, 24, 32, 41
- Defects in teas, 129 *et seq*
- Deterioration of teas, 16, 18, 86, 92, 112, 113, 114
- Dhool, evenness of, 72, 73, 74
 outturns, 54, 58, 72, 80
 order of firing of, 80
 prefiring grading of, 76
 production of, 13, 42 *et seq*, 57-58, 60, 72
 size of, 57, 72-73, 74, 84
 temperature of 13, 78, 83, 151
- Diagrams of rolling programmes, 124, 125, 126
- Double roll-breaking, 72
- Driers, *see also* Firing
 capacities, 97
 intake, 117, 120
 load of leaf, 89, 90
 maintenance and operation of, 93
 thermometers, 92
 tilting tray, 92
 use of, in withering, 40-41
 volume of air, 88
- Drying, *see also* Firing
 curves, 88, 91
 period of, 89
 technology of, 86
- Dry matter, solubility of, 11
 loss of, in withering, 23
- Dullness of infused leaf, 15, 33, 132

INDEX

Dust, 104

Elevation, *see* Altitude and Manufacture

Enzymes, 7, 9

- action of, during rolling, 10
- activity of, 9, 12
- fermentation by, 7, 8-9, 10
- inactivation of, during firing, 10, 87

Epicyclic pressure rolling, 45, 46, 47

Ethyl acetate extracts, of soluble matter, 11
of high and low grown teas, 11

Essential oils, *see* Aromatic constituents

Evaporation of water,
during firing, 86-87
during withering, 32-34

Exhaust temperature, 87, 89, 90, 92

Experiments, 133

Fannings grades, description of, 103
increasing outturn of, 105

Fans. area on fan inlet, 40
induced, 94
requirements, 38
use of. in withering, 37 *et seq*

Fermentation, 7 *et seq*, 77 *et seq*
after firing, *see* Post-fermentation
by enzymes, 7, 8-9, 10
changes in oxidizable matter during, 10-11
during rolling, 10, 51, 55-56, 78
effect of, 77
effect of charging interval on, 80, 119-120
effect of damaged leaf on, 24
effect of density of spread on, 84
effect of humidity on, 64-65, 82
effect of order of firing dhools on, 80
effect of pectic acid formation on, 12-13, 14
effect of period of, 77, 78, 117-119
effect of surface on, 84
effect of temperature on, 10, 13, 55, 56, 65, 78, 82-83
effect of thickness of spread on, 82
formation of condensation compounds during, 8, 9, 10
judgment of, 85
object of, 77
periods, 78-82, 117 *see also* Charging interval

Final firing, 93, 113

Fired tea, handling of, 93, 106
moisture content of, 86, 87, 91, 92, 98, 110, 112

INDEX

- Firewood, 95, 96
- Firing, 86 *et seq*, *see also* Drying and Driers
case-hardening, 86, 92, 112, 131
costs, 96
dhools, order of, 80-82
drier capacities, 97
exhaust temperatures 87, 89, 90
factors, influencing, 86
inlet temperatures, 87, 90, 97
load of leaf, 89, 90
maintenance and operation of driers, 93
moisture content of fired teas, 86, 87, 91, 92, 98, 110, 112
object of, 86
optimum conditions for, 93
period of drying, 89
precautions after, 93
stewing, 78, 90, 91, 131
stoves and furnaces, 94
technology of tea drying, 86
temperature 87
volume, of air, 88
- Flakiness in teas, 28, 50, 51, 57, 63, 104, 130
- Flat liquors' *see* Soft liquors
- Flavour, 14, 25, 35, 64, 65, 80
- Flowery grades description of , 102, 103
- Flue gases, 94-96
- Fluff, 106
- Flush, composition of, 21
moisture contents of parts of, 32
- Foreign matter, 41, 138-139
- Fresh leaf, *see* Green leaf
- Fuels combustion of, 95
coal, 95, 96
oil, 95-96
wood, 95, 96
- Furnaces, 94
- Going-off of tea, *see* Deterioration
- Grading, 99 *et seq*
before firing, 76
character of grades, 104
description of grades 102
general rules in, 99-102
greying of tea, 106
moisture absorption during, 108

INDEX

- Grading
 seives, 105
 sifting procedure, 99
 stalk extraction, 107
 winnowing of tea, 107
- Green leaf, and type of tea produced, 20-22, 33, 50, 73, 130
 caffeine in, 12
 composition of, 21
 condition of, 33
 damage to, 32
 fermenting properties of 51, 130
 in relation to rolling, 21, 49-50
 in relation to withering, 32, 33
 moisture content of, 23, 29-30
 outturn of made tea, 22
 outturn of withered leaf to, 29-30
 oxidizable matter in, 7, 9, 13, 21
 pectins in, 12
 physical composition of, 22
 treatment of, 24
 type of, 33, 49
- Greenness of liquors, 17, 18, 21, 24, 56, 77,80, 87,131 *see also* Astringency
 and Pungency
- Greying of tea, 106
- Hard withers, 31, 51, 118
- Harshness, *see* Greenness
- Heat, in rolling, 10, 48, 51, 54-57, 83, 147-150
- Heating of leaf, 24, 41
- High-grown quality, 50 59, 64
- Humidifying appliances, 56, 64
- Humidity, absolute, 140
- Humidity, relative, 26, 35 *et seq.* 82, 108, 142
- Humidity, tables, use of, 143
- Hygiene, 41, 84, 138-139
- Hygrometers, 26-27, 38, 109
- Hygrometric tables, 141, 142
- Hygrometry, 26-27, 35-36
- Hygroscopicity of tea 18, 93, 108, 109, 110, 112 *et seq.*
- Infused leaf, (infusion), 14, 25, 33, 51, 67, 85, 89, 131
- Inlet temperatures, firing, 87, 90, 97

INDEX

- Jat, 20, 31, 49, 51 130, 132
- Juices, 28, 31, 42, 49, 51, 62, 79, 129, 130, *see also* Cell sap
- Keeping quality, 16-17, 18, 86, 88, 112, 113
- Leaf, *see* Green leaf
- Light liquors, 79
- Linings, chest, 114-115
- Liquid fuel, *see* Oil
- Liquor characters, 17, 130-131
- Lofts, 34, 41
- Low-country manufacture. 19, 20, 29, 31, 49, 50, 58, 59, 63, 70, 73, 74
88, 102, 108, 120
- Made tea, outturn to green leaf, 22
outturn to withered leaf, 29, 31 51
- Maltiness, 21, 84, 131
- Manufacture, aims and objectives, 11, 13-14, 18
approach to, 19
pre manufacture influences, 20, 62
principles of, 7 *et seq*, 17
standard of plucking in, 21-22, 31, 33, 51
- Maturation, 19, 112, 114
and keeping quality, 16
- Mellowness, 17, 18, 77, 86, 87
- Mesh, roll-breakers, 50, 57, 58, 62, 72
sifters, 105-106
- Micro-organisms, 7, 84
- Mid-country manufacture, 50, 58, 63, 73
- Mist Chambers, *see* Humidifying appliances
- Moisture, absorption during sifting and picking, 108
absorption during storage, 93, 109, 110, 112 *et seq*
loss in fermenting 65, 82
loss in firing, 86,-87
loss in rolling, 65
loss in withering, 32-33
surface, on leaf, 23 29, 33, 41
- Moisture content, and keeping quality, 16-17, 18, 86, 92, 112 *et seq*
of air, 26, 140 *et seq*
of final fired teas, 113
of fired tea, 86, 87, 91, 92, 98, 110, 112

INDEX

- Moisture content,
 - of graded teas, 110
 - of green leaf, 23, 29-30
 - of packed teas, 112-113
 - of stalk, 32, 33
 - of stored teas 112
 - of withered leaf, 29-30, 51
- Muddy liquors. 16, 130
- Natural withering, 36
- Oil, for firing, 95, 96
- Orange Pekoe, 50, 103, 105
- Organization, 59, 116 *et seq*
 - charging interval, 59, 80, 119
 - drier intake, 117
 - factory record, 128
 - fermentating periods, 117 *see also* Charging interval
 - requirements, 116-117
 - roll-breaking, 122
 - rolling periods, 120
 - rolling programmes, 123
- Outturns, dhool, 54, 58, 72, 80
 - made tea to green leaf, 22
 - made tea to withered leaf 29, 31, 51,
 - relationship between, 145-146
 - withered leaf to green leaf, 29-30
- Oxidation, during rolling, 10
 - effect of pectic acid on 13-14
 - effect of temperature on. 10, 13
 - in dried tea 16, 86, 92, 112.
 - of chlorophyll, 14-15
 - of oxidizable matter, 10
- Oxidizable matter, 7, 9, 10
 - action of enzymes on, 9-10
 - and withering, 9
 - changes in solubility of, 11
 - effect of pectic acid on oxidation of, 13
 - range of variation of, in a shoot, 21
- Oxygen, absorption of, by tannins, 7-8
 - absorption of by dried tea, 16
- Packing, 114
- Pectase, 12
- Pectic acid, 13, 14. 15-17
- Pectins, 12, 14
- Pekoe, description of, 103
- Percentage wither, 29

INDEX

- Picking, 107-108
- Plucking, standard of, 33
in relation to grading, 104-105
in relation to manufacture, 21-22
in relation to rolling, 50
in relation to withering, 31, 33
- Polyphenols, 8
oxidase, 9
- Post-fermentation, 16, 18, 86, 112
- Pressure caps, 61
- Pressures in rolling, 45, 53, 54
- Programmes, rolling, 68-70, 116 *et seq* 124-127
considerations, 122 *et seq*
continuous, 68
orthodox, 123-127
- Pungency, 10, 17, 24
- Quality, 20, 24, 34, 35, 36, 48, 55, 64 131
effect of period of fermentation on, 56, 59, 77, 79, 80
in relation to firing, 86, 88, 89, 113
- Quinones, 15
- Rawness (or Rasp), 10,16,51,56,77. *see also* Greenness and Astringency
- Records, the keeping of, 128
- Reds, 33, 50, 64, 104, 107
- Refuse tea, *see* Waste tea
- Relative humidity, *see* Humidity
- Reversible withering 37
- Roll-breakers, capacities, 76
care of 75
mesh. 50, 57, 58, 62, 72, 123
- Roll-breaking, 13, 57, 71 *et seq* 122
duration of, 75, 122-123
general suggestion, 75
objectives, 71
prefiring grading. 76
- Roller. battens, 42-43, 60
charges, 52, 118 *et seq.* *see also* Charging Interval
cones, 43-44, 60, 61
pressure, 45, 53, 54
pressure, caps, 61
speeds, 53

INDEX

- Roller
tables, 43, 44, 46, 60-61
time tables, 127
- Rolling, 42, *et seq*
batten/pressure cap, 42, 60-61
battens, 42-43, 60
charges, 52, 118 *et seq*, *see also* Charging Interval
chemical changes during, 10
continuous, 67 *et seq*
epicyclic pressure 45, 46, 57
for appearance, 50, 58, 63
for high-grown quality, 50, 64
for tip, 50, 62
humidification for, 64-66
in relation to charging interval 59, 80, 119-120
in relation to degree of wither, 51
in relation to degree of pressure, 53
in relation to dhool outturn and size, 57
in relation to fermentation, 10, 78-83
in relation to fermenting properties of leaf 51
in relation to number of rolls, 48
in relation to period, 48, 120
in relation to pressure application, 45, 54
in relation to speed, 53
in relation to temperature, 55
in relation to type of leaf, 31, 49
in relation to type of tea required, 62-64
mechanical effect of, 48
mechanism of, 42
moisture loss in, 65
object of, 42
pressure application, method of, 54
pressure, degree of, 53
programmes, 68-70, 116 *et seq*, 124-127
temperatures, 55, 147-150
- Rolls, number and period of, 48, 63
- Round liquors, *see* Smooth liquors.
- Sap, leaf, *see* Juices
- Sieves, 105
- Sifting, *see also* Grading
moisture absorption during, 108
procedure, 99
- Smooth liquors, 16, 17, *see also* Mellowness
- Soft liquors, 16, 17, 33, 77, 84, 131
- Soft withers, 30-31, 51, 118
- Sour liquors, 35, 84
- Spreading, in fermentation, 14, 82 *et seq*
in firing, 89-90
in withering, 34, 41

INDEX

- Stalk, extraction of, 107
in general, *see* Reds
moisture in, 32, 33
- Stewing. 87, 90, 91, 131
- Storage, 113
and maturation, 16, 112
and moisture content, 93, 108, 109, 112. *et seq*
bins. 113-114
final firing, 113
- Stoves, 94
- Strength, 24, 77, 130
- Surface drying during fermentation, 82
- Surface moisture, *see* Moisture surface
- Tannins, 7-8
- Tasters, terms, 129 *et seq*, 134 *et seq*
- Tats condition of, 34
- Temperature, during fermentation, 64, 78-79, 82-83
during roll-breaking, 83, 151
during rolling, 55, 64, 78, 83, 147-150
during withering, 35, 39
effect on drying capacity of air, 26, 35, 140-144
effect on enzyme activity, 10
effect on fermentation *see* Fermentation
effect on oxidation, 10, 13
effect on quality, 36, 56, 57
exhaust, 87, 89, 90, 92
final firing, 113
inlet, 87, 90, 97
wet and dry bulb, 26, 35-36, 39, 57, 64
- Thermometers, 26-27, 92
- Tip, 20, 50, 62, 129
- Up-country manufacture, 20, 31, 49, 50, 56, 58, 59, 64, 74
- Waste tea, 22, 104, 110
- Water, boiling point of, 154
- Wet and dry bulb temperatures, 26, 35-36, 39, 57, 64
- Winnowing of tea, 107
- Wither, degree of, 30, 51, 97, 117-118
effect of condition of leaf on, 33
effect of damaged leaf on, 32
effect of drying capacity of air on, 35

INDEX

Wither,

- effect of standard of plucking on, 33
- effect of thickness of spread on, 34
- effect of type of leaf on, 31, 33
- effect on fermentation, 9, 10
- effect on resultant tea, 31, 34, 51
- evenness of, 31, 34, 38, 41, 51, 57, 132
- percentage, 29
- period of, 34

Withered leaf, damage to, 41

- outturn of made tea to, 29, 31, 51
- moisture content of 29-31, 51
- physical condition of, 28, 30
- temperature of, 35

Withering, 28 *et seq*

- and oxidizable matter, 9
- air mixture for, 39, 40
- air drying capacity of, in, 35
- artificial, 37
- chemical changes during 9, 11, 28
- conditioning of air in, 36, 39-41
- circulation of air in, 37, 41
- degree of wither 30, 51-52 97, 117-118
- factors influencing, 32 *et seq*
- hygrometric difference required for, 36, 37, 39
- in relation to standard of plucking, 31, 33
- in relation to thickness of spread, 34, 41
- in relation to type of leaf, 31, 33
- lofts, 34, 41
- loss in dry matter during, 23
- mechanism of 32
- natural, 36
- outturn made tea withered leaf, 29, 31, 51
- object of, 28
- percentage wither, 29
- period of, 34
- reversible, 37
- spread, thickness of, in, 34
- surface moisture, removal of, in, 33, 41
- tats, 34
- temperatures, 35, 39