

## TEA RESEARCH INSTITUTE OF SRI LANKA

Issued in: July 2009

Guideline No: 02/09

### GUIDELINES FOR USE OF SELECTIVE TEA HARVESTER

#### 1. Introduction

Harvesting of tea, known as 'plucking' is the most labour intensive and costliest field operation in tea cultivation. Usually, more than 70% of the workforce in a plantation is employed daily for plucking. Its contribution to the total cost of production is estimated to be in the range of 30 - 40%. More importantly, plucking practices adopted by growers influence growth and yield of tea and quality of the end product. In the present day context plucking of tea is seriously affected by the shortage of workers. Extending plucking rounds and hard plucking contribute to poor standard of leaf which in turn lead to low yield and poor quality of made tea. High proportions of damaged leaf have also been reported when men and sundry workers (women) are employed for harvesting to compensate for shortfall of skilled pluckers. In order to increase plucking efficiency and minimize leaf damage during harvesting, TRI Selective Tea Harvesters (TSTH) could be effectively used.

#### 2. TRI Selective Tea Harvester (TSTH)

There are varying types of plucking shears used in different tea growing countries. Most of them are modified garden shears with long handles and a leaf collecting tray or bag. Some have varying heights of steps above which the shoots are sheared to the collecting tray or bag. In Sri Lanka, the Tea Research Institute has designed a prototype shear without long and prominent handles which is known as TRI Selective Tea Harvester (TSTH). It weighs about 350g, which is less than the shears with long handles used in other countries. The leaf collecting tray is made of plastic with a cutting place raised (2.5cm) from the bottom and with a handle and perforations. The handle has a protruding edge about 2.5 cm above the top blade to guide and push shoots towards the leaf collecting tray. Two sharp blades made of durable steel are held together at one end by a nut and a bolt. The handle is fitted to the upper blade and the leaf collecting tray with perforations is fitted to the lower blade. When the top blade is moved over the lower blade in a shearing action, tea shoots captured in between the two blades is first bent towards the leaf collecting tray by the protruding edge of the small handle and are immediately severed. The cut shoots are deposited in the leaf collecting tray and any excess surface moisture of shoots is drained off through small perforations at the bottom (Figure 1).

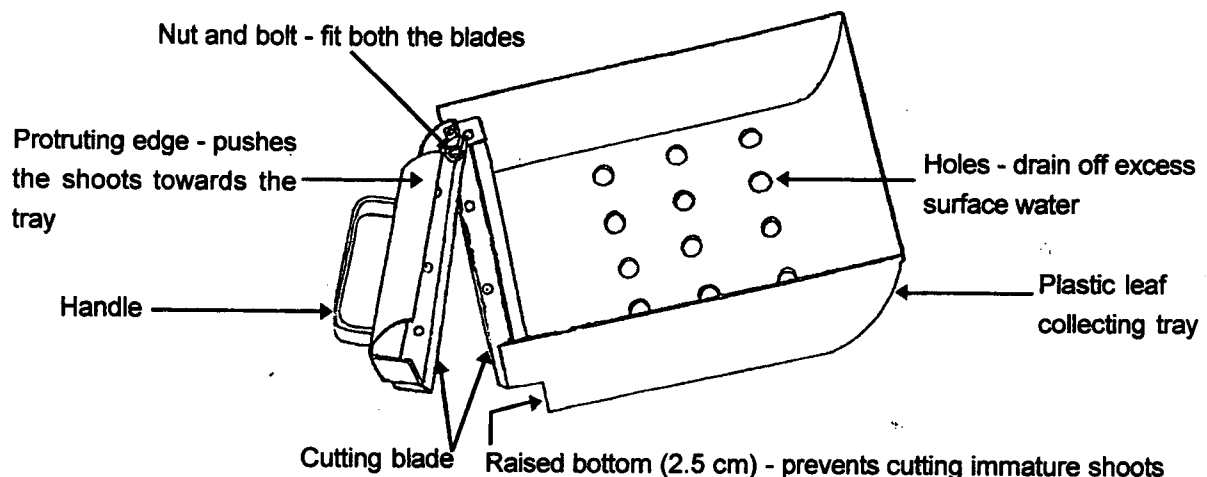

Figure 1. TRI selective tea harvester (TSTH)



Figure 2. Proper way of holding the selective tea harvester

### 3. Proper use of TSTH in the field

- The leaf collecting tray of the TSTH should be held on the palm of the left hand keeping four fingers under the bottom of the tray while holding the small handle by the right hand as shown in the Figure 2. Especially designed TSTH could be fabricated on demand for the left-handed operators.
- The small handle and the leaf collecting tray could be easily moved in a shearing action ensuring that both blades are perfectly moved one on the other, leaving no gap. This ensures automatic sharpening of the blades and a clean cut on the shoot without crushing them.
- In order to improve selectivity in harvesting of shoots and to maintain the plucking table, the user should direct the partly opened blades of the TSTH to the harvestable shoots, one or few at a time, depending on the shoot distribution without lowering the TSTH below the plucking table. Tea shoots should be cut using the first half of the blades from open end for improved selectivity.
- Shoots collected in the tray should be periodically emptied into a basket to avoid spilling out of the tray.
- Harvesting of shoots should begin from the nearest periphery of the bush progressing towards the furthest end covering the entire bush.
- All *banjis* left after harvesting by the TSTH should preferably be removed manually before moving to the next bush. Accumulated *banji* shoots if present, must be removed once in 2-3 rounds by a manual plucking round.
- Use of a suitable plucking basket helps leaf collection while harvesting with the TSTH
- Plucking rounds with TSTH depends on the selectivity achieved by the pluckers. However, to increase plucker intake and reduce labour use, plucking rounds could be extended by about 2 days more than the manual plucking rounds provided shoots do not over mature.
- The use of TSTH is difficult in tea fields closer to pruning and those on steep terrains. Benefits of using shears are also less during non cropping periods and dry spells where the majority of shoots are either small or dormant (*banji*) or when no proper plucking table is present particularly after tipping (fields brought into plucking after pruning). Hence, selection of tea fields must be done carefully to avoid unsuitable fields for the use of TSTH.
- Proper manuring along with foliar application of  $Zn\ SO_4$  is extremely important to induce bud break and to reduce *banji* formation.

COPYRIGHT

All rights reserved. No part of this publication may be reproduced or transmitted in any form or by any means, electronic or mechanical, including photocopying, recording or information storage and retrieval, without permission in writing from the Director, Tea Research Institute of Sri Lanka.